



Government of the People's Republic of Bangladesh  
**Bangladesh Economic Zones Authority (BEZA)**  
Prime Minister's Office

# **BANGABANDHU SHEIKH MUJIB SHILPANAGAR (BSMSN) MASTER PLAN**

27 September, 2020





Government of the People's Republic of Bangladesh

## Bangladesh Economic Zones Authority (BEZA)

Prime Minister's Office

Monem Business District (Level-12),  
111, Bir Uttam CR Dutta Rd Dhaka 1205, Bangladesh

# BANGABANDHU SHEIKH MUJIB SHILPANAGAR (BSMSN) MASTER PLAN

27 September, 2020

Submitted by



Joint Venture (JV) of SCPL-Sheltech-STUP



STUP Consultants Pvt. Ltd.

Project Name: Support to Capacity Building of Bangladesh Economic Zones Authority Project  
(Under Private Sector Development Support Project)  
IDA Credit No. 5769-BD (Additional Finance)

# **BANGABANDHU SHEIKH MUJIB SHILPANAGAR (BSMSN) MASTER PLAN**

## **Published By**

---



Government of the People's Republic of Bangladesh

**Bangladesh Economic Zones Authority (BEZA)**

Prime Minister's Office

## **Funded By**

---



## **Implemented By**

---

Support to Capacity Building of Bangladesh Economic

Zones Authority Project (STCB)

## **Consultant**

---



**Sheltech Consultants (Pvt.) Ltd.**



**STUP Consultants Pvt. Ltd.**

**STUP Consultants Pvt. Ltd.**

Joint Venture (JV) of SCPL-Sheltech-STUP

## **Copyright**

---

Government of the People's Republic of Bangladesh

**Bangladesh Economic Zones Authority (BEZA)**

Prime Minister's Office

## **First Edition**

---

September 2020

## Message of Executive Chairman



I am very glad to know that Bangladesh Economic Zones Authority (BEZA) is going to publish the Master Plan of Bangabandhu Sheikh Mujib Shilpanagar (BSMSN), a merry note for materializing the long-cherished vision of achieving greater economic, social and environmental benefits for Bangladesh. We are trying our best in all potential ways to create a congenial investment atmosphere for a smooth economic growth in our country being patronized by the Hon'ble Prime Minister, Sheikh Hasina who is the driving force of the organization. With a view to keeping the present investment trend uprising, BEZA has already established BSMSN which will become the 'premier' destination in a corridor covering Dhaka-BSMSN-Chattogram-Moheshkhali. We are optimistic that the Industrial City- BSMSN will become the first comprehensively planned city of Bangladesh. This international standard conglomerated zone will create an example of a smart, vibrant and multimodal platform with all modern amenities that are ensured in a world class business hub.

It is important to note that the Master Plan has been designed in a way so that BSMSN can be established as a dedicated industrial component maintaining the best environmental and social compliances. Different types of industries, infrastructures, logistic hubs have been placed in the master plan considering their categories with existing legal and logical provisions. There are provisions for light and medium industries, a port, and a separate heavy industrial area to support all types of warehousing, manufacturing, production activities within the zone. All road networks, powerhouses, green areas, resilient technologies, IT hubs, commercial and residential areas have been designed in such a way that in near future BSMSN will directly compete on an international platform with top tier zones of China, South Korea and the Middle East.

It is my great pleasure to thank all those international and national organizations which are directly and indirectly connected with the accomplishments of this master plan work. There is no denying of the fact that the master plan, being finalized following the directions and advices of Honourable Prime Minister, will motivate the concerned departments in implementing the required infrastructures for BSMSN. The consistent support from World Bank and its associated organizations is undeniable. I am also thankful to the consultant firms Sheltech- STUP and BEZA team for their laborious inputs in this master plan. I hope that BSMSN Master Plan will widen the vision of the investors and concerned to choose the best investment destination.

A handwritten signature in blue ink, appearing to read 'P. Chowdhury', written over a horizontal line.

**Paban Chowdhury**  
Executive Chairman  
Bangladesh Economic Zones Authority



# Table of Contents

Message of Executive Chairman .....	I
<b>TABLE OF CONTENTS .....</b>	<b>II</b>
List of Tables .....	VI
List of Figures .....	VII
List of Abbreviations .....	IX
<b>1. INTRODUCTION .....</b>	<b>1-1</b>
1.1 Project Background .....	1-1
1.2 Project Objectives .....	1-1
1.3 Objectives of the Part IV Report .....	1-2
1.4 Terms of Reference and Understanding of the Part IV Report .....	1-2
1.5 Location of Bangabandhu Sheikh Mujib Shilpanagar .....	1-4
<b>2. MASTER PLANNING OF BSMSN .....</b>	<b>2-1</b>
2.1 The BSMSN Planning Regime .....	2-1
2.2 Methodology .....	2-1
2.3 The Vision for BSMSN .....	2-2
2.4 The Value Proposition for BSMSN .....	2-3
2.5 The Structure Plan for BSMSN .....	2-3
2.5.1 The Regional Structure Plan for BSMSN .....	2-4
2.5.2 The BSMSN Site – Specific Structure Plan .....	2-6
2.6 Planning Principles for BSMSN .....	2-8
2.7 The BSMSN Master Plan .....	2-9
2.7.1 Inputs into the Master Plan .....	2-9
2.7.2 The Master Plan .....	2-9
2.8 Land Uses for BSMSN .....	2-11
2.8.1 Diverse Land Use Designations .....	2-11
2.9 Precinct Plan for BSMSN .....	2-11
2.9.1 A Series of Distinct Precincts .....	2-11
2.10 Precinct Descriptions/Development Guidelines .....	2-12
2.10.1 Precinct A: Residential and Support Amenities .....	2-14
2.10.2 Precinct A1 .....	2-16
2.10.3 Precinct B: City Center/Business Hub .....	2-18
2.10.4 Precinct C: Health and Education Centre .....	2-20
2.10.5 Precinct D: Mixed Use/Residential .....	2-23
2.10.6 Precinct E: Administrative/Institutional Centre .....	2-25
2.10.7 Precinct F : Light/ Medium Industrial Area .....	2-27
2.10.8 Precinct G: Port and Logistics Hub .....	2-29
2.10.9 Precinct H: Forest/Transitional Area: Additional Port/Logistics .....	2-32
2.10.10 Precinct I: Heavy Industrial Area .....	2-33
2.10.11 Precinct J: Open Space .....	2-34
2.10.12 Precinct K: Leisure/Entertainment Area .....	2-36
2.10.13 Precinct L: Cultural Center .....	2-38
2.10.14 Secondary Plans for BSMSN Precincts .....	2-39
2.10.15 Monitoring and Assessment of BSMSN .....	2-39
2.11 Phasing of BSMSN .....	2-40

<b>3.</b>	<b>DEVELOPMENT POLICIES AND GUIDELINES .....</b>	<b>3-1</b>
3.1	General Guiding Policies.....	3-1
3.1.1	The City Core/Central Business District.....	3-2
3.1.2	Tall Buildings.....	3-3
3.1.3	Residential Areas .....	3-3
3.1.4	Administrative/Institutional/Health/Education Areas.....	3-4
3.1.5	Cultural Areas.....	3-5
3.1.6	Light and Medium Industrial Area .....	3-5
3.1.7	Port and Logistics Area.....	3-6
3.1.8	Heavy Industrial Area.....	3-7
3.1.9	Parks and Open Space Areas .....	3-7
3.1.10	Area of Influence .....	3-8
3.1.11	Multi-Modal Transport Platform.....	3-9
3.1.12	Utility Corridors .....	3-9
3.1.13	Filling Stations.....	3-10
3.1.14	The Public Realm .....	3-11
3.1.15	Public Art.....	3-12
3.1.16	Applicability of Bangladesh National Building Code (BNBC).....	3-12
3.2	General Environmental Guidelines.....	3-12
3.3	Resilience Infrastructure Planning and Design for BSMSN.....	3-14
3.3.1	BSMSN Fueled By Next Generation Infrastructure .....	3-14
3.3.2	Climate Change and Natural Hazard Risks Facing BSMSN .....	3-16
3.3.3	Key BSMSN Infrastructure .....	3-20
3.3.4	Approaches to Enhance Resilience Through the Master Plan .....	3-21
3.3.5	Resilience Options for BSMSN’s Infrastructure .....	3-22
3.3.6	Transport Within BSMSN .....	3-24
<b>4.</b>	<b>INFRASTRUCTURE DEVELOPMENT PLAN FOR BSMSN.....</b>	<b>4-1</b>
4.1	Transport Network.....	4-1
4.1.1	Overview.....	4-1
4.1.2	Transport Assumptions.....	4-2
4.1.3	Proposed Transport Network of BSMSN.....	4-3
4.1.4	Cost Estimations for the Transportation Network.....	4-18
4.2	Power Networks within BSMSN.....	4-21
4.2.1	Overview .....	4-21
4.2.2	Electricity Demand Assessment .....	4-21
4.2.3	Source of Power.....	4-23
4.2.4	Transmission and Distribution Network .....	4-24
4.2.5	Cost Estimation for Electrical Infrastructure.....	4-32
4.3	Gas Network.....	4-33
4.3.1	Overview .....	4-33
4.3.2	Gas Demand Projections .....	4-35
4.3.3	Gas Supply Components .....	4-37
4.3.4	Gas Supply Network.....	4-42
4.3.5	Cost Estimations for the Gas Network.....	4-44
4.4	The Water Supply System.....	4-47
4.4.1	Background Analysis .....	4-47
4.4.2	Water Demand Assessment.....	4-47
4.4.3	Source of Raw Water.....	4-51
4.4.4	Different Water Supply Components.....	4-53
4.4.5	Interventions Required for the Water Supply System.....	4-55



4.4.6	Cost Estimations for Water Supply System.....	4-59
4.5	Storm Water Drainage System.....	4-60
4.5.1	Background Analysis .....	4-60
4.5.2	Rainfall Pattern.....	4-61
4.5.3	System Planning.....	4-61
4.5.4	Proposed Storm Water Drainage System.....	4-62
4.5.5	Cost Estimations for the Storm Water Drainage System.....	4-66
4.6	Domestic and Industrial Liquid Waste Handling System.....	4-67
4.6.1	Background Analysis .....	4-67
4.6.2	Sewage Collection and Transportation System .....	4-67
4.6.3	Domestic and Industrial Liquid Waste Handling System.....	4-68
4.6.4	Sewage Treatment Plant (STP).....	4-71
4.6.5	Common Effluent Treatment Plant (CETP).....	4-74
4.6.6	Cost Estimation of Sewerage System .....	4-78
4.7	Telecommunication Network.....	4-79
4.7.1	Overview.....	4-79
4.7.2	Future Direction.....	4-81
4.8	BSMSN Plantation Plan.....	4-82
4.8.1	Green Streets: The Core Concept .....	4-82
4.8.2	Benefits of Plantation/Green Streets.....	4-82
4.8.3	Options for Creating Green Streets .....	4-82
4.8.4	Plantation Along with Roads, Railway and Natural Channels .....	4-83
4.8.5	Other Potential Areas for Plantation.....	4-85
4.8.6	Costing of the BSMSN Plantation Plan.....	4-87
4.9	Waste Management .....	4-87
4.9.1	Background Analysis .....	4-87
4.9.2	Waste Management Plan Approach.....	4-90
4.9.3	Management of Municipal Solid Waste (MSW).....	4-96
4.9.4	Management of Medical Waste (MW).....	4-100
4.9.5	Management of Plastic Waste.....	4-100
4.9.6	Management of Industrial Solid Waste (MSW).....	4-101
4.9.7	Waste Management Approach .....	4-106
4.9.8	Policies to be Adopted in BSMSN.....	4-113
4.9.9	Cost Estimations of Solid Waste Management in BSMSN .....	4-120
4.10	Summary of Cost Estimations for the BSMSN Project .....	4-120
<b>5.</b>	<b>SOCIAL ISSUES WITHIN BSMSN.....</b>	<b>5-1</b>
5.1	Background Analysis .....	5-1
5.2	People and Structures Likely to be Affected in BSMSN.....	5-1
5.2.1	Finding on Off-Site Area .....	5-1
5.2.2	Findings for On-Site Area.....	5-2
5.3	Social Impact and Mitigation.....	5-2
5.3.1	Resettlement Issues and Plan.....	5-3
5.4	Corporate Social Responsibilities (CSR) Activities.....	5-5
<b>ANNEXURE</b>	<b>.....</b>	<b>1</b>
	Annexure 3.1: Analysis of Flood and Seismic Resilience of Flood Protection and Management Infrastructure and Site Development .....	1
	Annexure 3.2: Infrastructure Resilience and Performance Enhancement Measures .....	5
	Annexure 3.3 : References .....	8
	Annexure 4.1: Typical Trumpet Interchange Intersection .....	9
	Annexure 4.2: Typical Design for Rotary Intersection .....	10

Annexure 4.3: Typical Design for 4 Arm Intersection .....	11
Annexure 4.4 Typical Design for 3 Arm Intersection.....	12
Annexure 4.5: Table Year Wise Gas Demand (in mmcf) up to 2040 in BSMSN area .....	13
Annexure 4.6 : Salient Details of the Water Supply System.....	14
Annexure 4.7 : Storm Runoff Contribution to Different Drainage Catchment Areas .....	20
Annexure 4.8 : Salient Details of Liquid Waste Collection System .....	22
Annexure 4.9: Calculation for the Size of the Landfill for BSMSN.....	27
Annexure 4.10 : Cost Estimation of Total Project.....	29
Annexure 5.1: Affected Households.....	37

## List of Tables

Table 1-1: Location of BSMSN.....	1-4
Table 2-1: BSMSN Precincts by Size.....	2-9
Table 2-2: Precincts and Land Uses.....	2-11
Table 2-3: BSMSN Precincts by Percentage of Land.....	2-12
Table 3-1: Key Types of Infrastructure Services and Assets Planned for BSMSN.....	3-20
Table 4-1: Regional Transport Network Improvements.....	4-5
Table 4-2 Minimum Pavement Layers.....	4-8
Table 4-3: Cost Estimations for Off- Site Transport Infrastructure.....	4-18
Table 4-4: Cost Estimation of On Site Transport Infrastructure.....	4-20
Table 4-5: Demand Assessment of Electricity for BSMSN.....	4-21
Table 4-6: De-Rated Capacity of Power Plants as of May 2020.....	4-23
Table 4-7: System Generation and Demand Scenario.....	4-23
Table 4-8: Expected On-Site Generation.....	4-24
Table 4-9: Length of Inter Connection Lines.....	4-26
Table 4-10: Location of Substations.....	4-27
Table 4-11: Average Land Required for Different Voltage Levels.....	4-29
Table 4-12: Right of Way and Corridor for Overhead Line and Underground Cable Line Respectively.....	4-29
Table 4-13: Secondary Distribution Network.....	4-30
Table 4-14: Estimated Distance of Links of 33 KV and 11 KV Network.....	4-30
Table 4-15: Potential Development Activities and Time Line.....	4-31
Table 4-16 Cost Estimations for Power Network.....	4-33
Table 4-17 Gas Demand for Different Industrial Categories.....	4-35
Table 4-18: Minimum Land Acquisition Required for a Pipeline.....	4-40
Table 4-19: Minimum Depth of Pipeline for BSMSN.....	4-40
Table 4-20: Cost Estimation for Gas Network Plan.....	4-44
Table 4-21 Estimated Phase-Wise Net and Gross Water Requirements.....	4-48
Table 4-22 Water Production Planning.....	4-50
Table 4-23: Land Area Requirements for Various Installations for the Water Supply System.....	4-56
Table 4-24 Off-Site Infrastructure Cost for Water Supply System.....	4-59
Table 4-25: On-Site Infrastructure Cost for Water Supply System.....	4-59
Table 4-26: On-Site Infrastructure Cost for Storm Water Drainage System.....	4-66
Table 4-27: Capacity Requirements for the STPs.....	4-72
Table 4-28: Recommended Quality Standards for Treated Effluent.....	4-72
Table 4-29: Land Area Requirements for Construction of Sewage Treatment Plants.....	4-74
Table 4-30: Capacity Requirements for the CETPs.....	4-75
Table 4-31: Proposed Inlet Effluent Quality Standards for CETP.....	4-76
Table 4-32: Recommended Treated Effluent Quality Standard for CETP.....	4-76
Table 4-33: Land Area Requirements Construction of Common Effluent Treatment Plants.....	4-78
Table 4-34 On-Site Infrastructure Cost for Liquid Waste Handling System.....	4-78
Table 4-35: List of Trees to be Considered Within BSMSN.....	4-84
Table 4-36: Other Potential Areas for Plantation.....	4-85
Table 4-37 Type of Waste Generation in BSMSN.....	4-88
Table 4-38 Policy Legal Framework of Waste Management of BSMSN.....	4-91
Table 4-39: Average Composition of MSW Anticipated in BSMSN.....	4-97
Table 4-40 Source of Generation of Some Major Industrial Solid Waste.....	4-102
Table 4-41 Industrial Solid Waste Generation in BSMSN in 2040.....	4-105
Table 4-42 Cost Estimation of Solid Waste Management.....	4-120
Table 4-43: Summary of Cost Estimations for the BSMSN Project.....	4-120
Table 5-1: Information on Approach Roads to BSMSN.....	5-1
Table 5-2: Social Issues, Their Impacts and Strategies for Risk Mitigation.....	5-2
Table 5-3: Recommended CSR Activities.....	5-5

## List of Figures

Figure 1-1: Regional Location Map of BSMSN.....	1-4
Figure 2-1: Regional Structure Plan for BSMSN.....	2-5
Figure 2-2 Site Structure Plan.....	2-7
Figure 2-3: The Master Plan for Bangabandhu Sheikh Mujib Shilpanagar (BSMSN) .....	2-10
Figure 2-4: Precinct Plan for BSMSN.....	2-13
Figure 2-5: BSMSN Precinct A.....	2-14
Figure 2-6 BSMSN Precinct A1.....	2-17
Figure 2-7: BSMSN Precinct B.....	2-18
Figure 2-8: BSMSN Precinct C.....	2-21
Figure 2-9: BSMSN Precinct D.....	2-23
Figure 2-10: Precinct E of BSMSN.....	2-25
Figure 2-11: BSMSN Precinct F.....	2-27
Figure 2-12: BSMSN Precinct G.....	2-29
Figure 2-13: BSMSN Precinct H.....	2-32
Figure 2-14: BSMSN Precinct I.....	2-33
Figure 2-15: BSMSN Precinct J.....	2-35
Figure 2-16: BSMSN Precinct K.....	2-36
Figure 2-17: BSMSN Precinct L.....	2-38
Figure 2-18: The BSMSN Phasing Plan.....	2-41
Figure 3-1: A Framework for Analyzing How Natural Shocks Affect People and Firms.....	3-14
Figure 3-2 Flood Hazards for the Target Area.....	3-17
Figure 3-3: Seismic Map of Bangladesh.....	3-18
Figure 3-4: Geological Map.....	3-19
Figure 3-5: Site Characteristics.....	3-20
Figure 4-1: Regional Network Improvements for BSMSN.....	4-7
Figure 4-2: Road Network Within BSMSN.....	4-9
Figure 4-3: Cross section and Plan of 20m ROW Collector Street.....	4-10
Figure 4-4: Cross section and Plan of 30m ROW Sub-Arterial Type Road.....	4-11
Figure 4-5 Cross Section and Plan of 40m ROW Sub-Arterial Type Road.....	4-12
Figure 4-6 Cross Section and Plan of 60m ROW Arterial Type Road.....	4-13
Figure 4-7 Cross Section and Plan of 100m ROW Arterial Road (with Rail Track).....	4-14
Figure 4-8 Cross Section and Plan of 90m ROW Arterial Road (Northern Part).....	4-15
Figure 4-9: Long Term Demand.....	4-22
Figure 4-10: Peak Demand Curve.....	4-22
Figure 4-11: HV Electrical Installation Around BSMSN.....	4-25
Figure 4-12: Single Line Diagram of High Voltage Network in BSMSN, Mirsharai, Feni and Sitakundo.....	4-27
Figure 4-13: BSMSN Power Network Plan.....	4-28
Figure 4-14: BSMSN Gas Network Plan.....	4-43
Figure 4-15: Representation of Ultimate Water Demand for Year 2040 For BSMSN.....	4-48
Figure 4-16 Water Balance Diagram for Year 2040 for BSMSN.....	4-49
Figure 4-17: Typical Process Diagram of a Desalination Plant.....	4-54
Figure 4-18: Location of Different Water Supply Components of BSMSN.....	4-57
Figure 4-19: Command Area of BSMSN Water Supply Components.....	4-58
Figure 4-20: BSMSN Drainage Network Plan.....	4-64
Figure 4-21: Catchment Area of Drainage Channels Across BSMSN.....	4-65
Figure 4-22: Domestic and Industrial Liquid Waste Handling System with Major Installations.....	4-69
Figure 4-23: Indicative Command Area of Domestic and Industrial Liquid Waste Handling System.....	4-70
Figure 4-24 Process Flow Diagram of Oxidation Ditch System.....	4-72
Figure 4-25: Process Flow Diagram for Sludge Treatment.....	4-73
Figure 4-26: Optical Fiber Network of BTCL.....	4-80
Figure 4-27: Green Areas Around BSMSN.....	4-86
Figure 4-28 Land Area for Industrial and Non-Industrial Activities.....	4-87
Figure 4-29 Waste Flow Diagram for BSMSN.....	4-89
Figure 4-30: Solid Waste Facilities in BSMSN.....	4-98
Figure 4-31 Waste Management Approach.....	4-108
Figure 4-32 Waste Management Scheme.....	4-109
Figure 4-33 Waste Minimization, Recovery and Utilization.....	4-110
Figure 4-34 Waste Manifest (e- Manifest) system.....	4-112

*Figure 4-35: Priority Concept of Integrated Waste Management*..... 4-114  
*Figure 4-36: Sustainable Resource-Efficient Economy with 3Rs (Reduce, Reuse and Recycling)* ..... 4-117  
*Figure 4-37 Waste Management Hierarchy*..... 4-117  
*Figure 5-1: Resettlement Areas in BSMSN* ..... 5-4

## List of Abbreviations

BDT	Bangladeshi Taka
BEZA	Bangladesh Economic Zones Authority
BM	Benchmark
BREB	Bangladesh Rural Electrification Board
BWDB	Bangladesh Water Development Board
CHEC	China Harbour Engineering Company Ltd.
DLRS	Department of Land Record and Surveys
DOE	Department of Environment
EIA	Environmental Impact Assessment
EIP	Eco Industrial Park
EMF	Environmental Management Framework
ESMF	Environmental and Social Management Framework
EZ	Economic Zone
FDI	Foreign Direct Investment
FPS	Frames per second
FTPP	Framework for Tribal Peoples Plan
GCP	Ground Control Point
GIS	Geographic Information System
GPS	Global Positioning System
IEE	Initial Environmental Examination
ISO	International Organization for Standardization
IWM	Institute of Water Modelling
JDI	Japan Development Institute
JICA	Japan International Cooperation Agency
LGED	Local Government Engineering Department
NGO	Non-governmental Organization
PSDSP	Private Sector Development Support Project
PTMC	Project Technical Management Committee
PWC	PricewaterhouseCoopers Pvt Ltd
PWD	Public Works Department
RHD	Roads and Highways Department
RS	Revised Survey/ Revenue Survey
RSMF	Resettlement and Social Management Framework
RTK	Real Time Kinematic
SA	State Acquisition
SCPL	Sheltech Consultants (Pvt.) Ltd.
SEZ	Special Economic Zone
SIA	Social Impact Assessment
SOB	Survey of Bangladesh
SRDI	Soil Resource Development Institute
TCP	Temporary Control Point
ToR	Terms of Reference
UNO	Upazila Nirbahi Officer
USD	United States Dollar
BSMSN	Bangabandhu Sheikh Mujib Shilpanagar
FDI	Foreign Direct Investment
PMO	Prime Minister's Office
WBG	World Bank Group
PSDSP	Private Sector Development Support Project
HDPE	High-Density Polyethylene
CETP	Common Effluent Treatment Plant
STP	Sewage Treatment Plant
UFW	Unaccounted for Water
MLD	Millions of Liters per Day
WTP	Water Treatment Plant

MSL	Mean Sea Level
BOD	Biochemical Oxygen Demand
SCADA	Supervisory Control and Data Acquisition
TSDf	Treatment Storage Disposal Facility
FAO	Food and Agriculture Organization
IUCN	International Union for Conservation of Nature
CSR	Corporate Social Responsibilities





A blurred cityscape with a road leading towards skyscrapers under a bright sky. The text "1. Introduction" is overlaid in the center.

# ***1. Introduction***



# 1. Introduction

## 1.1 Project Background

In Bangladesh, Export Processing Zones (EPZs) were a successful tool to boost the country's economy. The EPZ model was used as a "strategic instrument" to attract Foreign Direct Investment (FDI) and deal with shortcomings of the overall investment climate in the country. Bangladesh's EPZ model however, had its limits - both in terms of its cumulative impacts and spill-over effects into the domestic economy. As an exporting enclave, EPZs provided little in the way of backward or forward linkages with the domestic economy, resulting in low technology and efficiencies, which normally accompanied foreign investment. In addition, investments in other sectors beyond the RMG segment, did not materialize.

To address these challenges, the Government of Bangladesh (GoB) examined the more modern regime of Economic Zones (EZs) and drew upon numerous successful examples from around the world. In August 2010, the Bangladesh Economic Zone Act was passed in Parliament, providing an overall framework for establishing EZs throughout Bangladesh. Under this Act, the Economic Zone Authority (BEZA) was established under the Prime Minister's Office (PMO) and is governed by a Board chaired by the Prime Minister. The EZ law provides the legal coverage for attracting and leveraging private sector investment in the development of zones, (as a zone developer or operator), and in the provision of providing infrastructure services, such as power, water, drainage, sewerage, effluent treatment, wastewater treatment, telecom etc. The law also allows for the development of EZs and infrastructure through a Public-Private Partnership (PPP) mechanism.

At present, the GoB with the support of the World Bank Group (WBG) is implementing the Private Sector Development Support Project (PSDSP), which pilots EZ projects under the new EZ model. The program aims to create viable EZs and promotes the removal of key barriers and constraints facing the private sector. The project also supports: i) off-site infrastructure for EZs, ii) the creation of serviced industrial land, and iii) the use of good social and environmental practices.

## 1.2 Project Objectives

The objective of the Bangabandhu Sheikh Mujib Shilpanagar (BSMSN) Master Plan is to:

- examine the BSMSN site,
- document its existing conditions,
- identify the sites opportunities and constraints, and
- prepare a best practice, 20-year master plan and a planning regime for the zone.

The scope of work under this project included:

- A review of all policies, studies and plans previously prepared for BSMSN and its surrounding area and meet with relevant stakeholders,
- The preparation of base maps for the BSMSN area/area of influence in order to accurately document the existing physical conditions/features of the land, community, infrastructure /utilities, land uses and moveable/non-moveable property etc.,
- To prepare/validate/revise the development program for BSMSN and undertake a transport assessment,

- To develop a Master Plan, Land Use Plan, Zoning Plan, and Phasing Plan for the BSMSN project utilizing green and resilient technology and mechanisms to mitigate impacts of natural disasters and climate change,
- To conduct a stakeholder workshop to vet the master planning and regime for BSMSN and incorporate feedback, and
- Prepare two investment promotion videos for the BSMSN.

### 1.3 Objectives of the Part IV Report

The BSMSN Master Plan focuses on the comprehensive, short, medium and long-term planning of the BSMSN site and area of influence. Report IV is based on the outcomes of the three, previous reports and includes the following:

- A BSMSN master plan and land use plan for the project site,
- Identification of zoning permissions,
- A phasing structure for the successful implementation of the project,
- A set of Urban Design guidelines,
- Development principles for implementing on and offsite infrastructure/utilities, and
- An outline of requirements to ensure the BSMSN project is created to be a 'Sustainable Industrial City'.

It is intended that BSMSN Report Part IV will be the reference document for all development in BSMSN. It will be updated every 5 years to ensure it remains relevant.

### 1.4 Terms of Reference and Understanding of the Part IV Report

The detailed Terms of Reference (ToR) for the Project Report IV includes the following tasks:

#### **Task 7: Master Planning**

The team will prepare a detailed master plan/ land use plan for BSMSN. The plan will consider climate, weather change and environmental friendliness while placing i) the street and block network throughout the site, ii) main connection point (highways and Roads) with the neighboring areas/ areas of influence, iii) a hierarchy of road, transport and logistics networks within/ and outside the BSMSN project, including the rail network as per transport study, iv) land uses such as industrial, residential, retail, commercial, institutional, supporting amenities and open space etc., v) key administrative (for EZs) and institutional (schools, universities, hospitals, clinics or others etc.) facilities, vi) detailed plans for the EZ areas minimizing any adjacency issues, and vii) design of the lakes and/or reservoirs.

A detailed zoning plan is also required for the BSMSN project. This plan will set out BSMSN project's: i) densities, ii) height limits, iii) setbacks (side yard, rear yard, and property line), and iv) open space requirements. Once the master plan/land use plan and zoning plans are completed, the site should be phased according to the demand, which was identified in Task 5 in part III. It is critically important that the phasing of the project matches this demand.

Lastly, urban design guidelines are required for the entire BSMSN project. The urban design guidelines will include: i) access to plots, ii) building facades, iii) servicing and loading; iv) parking, v) landscaping, vi) signage, vii) lightening, viii) street furniture ix) Road and sidewalk x) views to water.

### **Task 7 Deliverables**

- A master plan/land use plan for the BSMSN project.
- A zoning plan for the project that identifies permitted densities, height limits, and setbacks.
- A phasing plan for the site in accordance with proposed market demand over a 20-year period.
- Urban design guidelines for the BSMSN project.

### **Task 8: On and off-site infrastructure**

The team will prepare a set of infrastructure and utility line drawings (not construction drawings) to match the master plan/land use plan, zoning plan and phasing plan and proposed activities within the BSMSN project as set out in Task 5. The team will meet with local infrastructure and utility agencies/providers to confirm/guarantee utilities to support the BSMSN project. The infrastructure and utilities required for this project include i) all onsite earthworks (the raising of land, shoring up the water's edge, flooding/drainage mitigation techniques/plans etc.) in plan format, as well as, ii) plans for all roads, power, gas, water, drainage, sewerage, storm water, coastal flooding (for a 100year surge), waste water/effluent treatment, fire, lighting, fencing, and telecom networks etc. The team will consider a consistent scale for on-site infrastructure drawings. All on-site infrastructure and utilities would be designed to utilize green technology, minimize waste, and promote water/power saving measures, and utilize recycling mechanisms, where possible. The team will provide a detailed outline of the necessary off-site infrastructure projects/requirements, costs and timing of these infrastructure projects, in order to not delay the project.

The cost estimates within 15% accuracy and 10% contingency will include land, resettlement, site preparation, and on-site and off-site infrastructure according to phase.

### **Task 8 Deliverables**

- On-site infrastructure and utility plans and cost estimates for the BSMSN project, as outlined above.
- Off-site infrastructure and utility plans, costs, timeframes for the BSMSN project, as outlined above.
- A waste management plan for the BSMSN project as outlined above.
- Total project costs/phased project cost calculations for the BSMSN project as outlined above.
- A set of large-scale infrastructure and utility plans for presentations/discussion.

### **Task 9: Consultation with relevant stakeholders**

The team holds a workshop to present their results to BEZA and relevant stakeholders (public, private and civil society). The purpose of this workshop is to explain the project to a wider audience and to obtain critical inputs to complete the work. The team is expected to organize the workshop and incorporate stakeholder's comments into their final report. The team conducts a series of public meetings with the greater community at the union and upazila level to understand the public/civil societies concerns.

### **Task 9 Deliverables**

- Finalize the report incorporating the comments received from the workshop and meeting.

## 1.5 Location of Bangabandhu Sheikh Mujib Shilpanagar

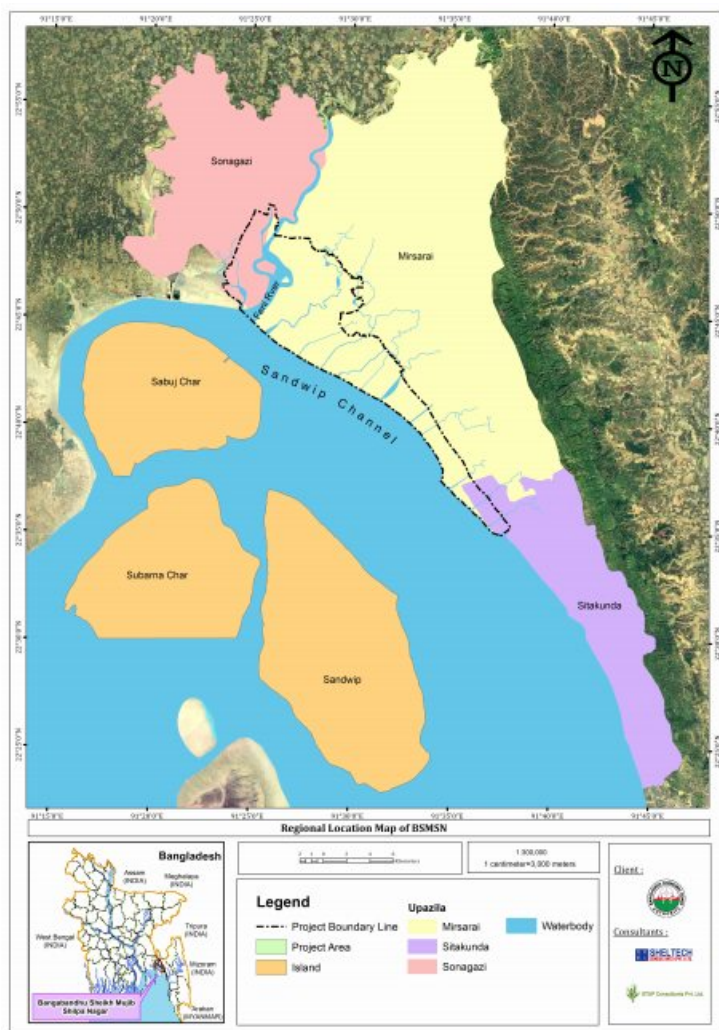

Figure 1-1: Regional Location Map of BSMSN

The BSMSN site (Figure 1-1) is located 200 kilometers (km) from Dhaka, 60 km from Chattogram, 70 km from Chattogram Port and the Shah Amanat International Airport and 330 km from Sylhet. The BSMSN Master Plan area is covered in the two districts, three upazilas, and 6 unions and comprised of 26 mouzas.

BSMSN has a total land area of 33,805 acres or 136.86 square kilometers (km<sup>2</sup>) (mostly reclaimed land) with a 25 km coastline along the Sandwip Channel in the Bay of Bengal. The land elevation on the site varies from the site's lowest point at -3.33 meters (m) MSL to the highest point at +8.71m MSL.

Before development of the BSMSN, the site was comprised of: i) 27.6% idle/barren lands, ii) 31.65% mangroves/forest/vegetation, iii) 8.71% water bodies/canals and iv) 6.53% under development. The site location is a moderate to high monsoon climatic area with an average annual rainfall of 500mm. The average temperature on the site varies between 15-25 degrees Celsius annually.

Table 1-1: Location of BSMSN

District	Upazila	Union
Chattogram	Mirsarai	Saherkhali
		Ichhakhali
	Sitakunda	Muradpur
		Saidpur
Feni	Sonagazi	Sonagazi
		Char Chandina

An aerial, high-angle photograph of a large, modern building complex, likely a university or government facility. The building has a prominent white facade and a flat roof. It is surrounded by a parking lot with several cars and a road with lane markings. The image is faded and serves as a background for the text.

## ***2. Master Planning of BSMSN***





## 2. Master Planning of BSMSN

### 2.1 The BSMSN Planning Regime

The BSMSN Planning Regime is a policy framework, which directs and manages the planning, design, and implementation of the BSMSN zone in the short, medium and long-term. This Planning Regime sets out: i) a vision, ii) value proposition and iii) structure plan for the BSMSN region as well as for the specific BSMSN site. It also provides: i) planning principles, ii) guiding policies, iii) a master plan with accompanying land use/zoning/precinct and transport maps, and iv) development guidelines to help shape the urban/industrial economic, environmental, social, and natural environment of the economic zone. Lastly, the Regime outlines the appropriate green technology and environmental and resilience measures, which need to be introduced into the BSMSN Master Plan to make the zone sustainable from natural disasters and climate change.

Beyond being a statement of intent and direction, the BSMSN Planning Regime and Master Plan is a legal document, defined under the Bangladesh Economic Zone Act 2010 and its implementing regulations. This report lays out the basis for the planning and design of BSMSN and the necessary development requirements for the approval of future development applications.

### 2.2 Methodology

The following international best practice methodology was used to prepare the Planning Regime and Master Plan for BSMSN:

- **Undertook a survey and assessment of BSMSN’s location, physical characteristics and attributes of the site and its surrounding area of influence, as well as the existing infrastructure in and around the zone.** This included a review of the land’s topography, physical features, hydrology, access/proximity to infrastructure/utilities, environmental/social/climate change conditions, transport and quality of life factors etc.<sup>1</sup>.
- **Prepared a transport assessment, development program and demand projections for BSMSN over a 20-year period<sup>2</sup>.** This included a review/due diligence and revision of past development programs for BSMSN, an examination of the short, medium and long-term transport and logistics patterns and modal-split requirements for the zone as the urban and industrial environment expands, and a 20-year demand forecast for all land use designations and industrial sectors proposed within BSMSN.
- **Reviewed the environmental and social issues existing and related to the development of the BSMSN site.** This included an examination of the environmental/social legislation and requirements which the economic zone project must comply with, as well as, an assessment of the existing environmental/social issues and concerns on the site.
- **Held workshops and stakeholder engagement on reports Part I-III and key aspects (opportunities, constraints, weaknesses, and threats) for the BSMSN Master Plan.** A series of

<sup>1</sup> Part I Final Report of the BSMSN Master Plan

<sup>2</sup> Part II and Part III: Final Reports of the BSMSN Master Plan

stakeholder workshops and engagement meetings were held to discuss the planning, design and implementation of BSMSN and its Master Plan.

- **Developed a comprehensive Planning Regime and Master Plan for BSMSN, which will be used to guide zone development over a 20-year period.** The planning regime includes: i) a vision, ii) a value proposition, iii) planning principles, iv) guiding policies, v) a structure plan, vi) a master plan, vii) a land use plan, viii) a zoning plan, ix) a precinct plan, x) a transport plan, and xi) development guidelines. This regime lays out the comprehensive planning for the development of the BSMSN over a 20-year period.

## 2.3 The Vision for BSMSN

Over a two-year period, a number of workshops and meetings were undertaken with relevant public and private stakeholders to discuss the vision and development direction for BSMSN and its surrounding region. From these series of stakeholder engagements, a vision was prepared for BSMSN, which is intended to: i) maximize the development potential of the project, ii) create more value for BSMSN, and iii) provide greater economic, social and environmental benefits for the region and Bangladesh.

Stakeholders determined that BSMSN's vision must be **'bold, innovative and competitive'** to be successful. Hence, it was decided that BSMSN will be more than just an economic zone. It will be the first, **large-scale, mixed use, combined urban/industrial city and economic zone** in Bangladesh, and will be unlike any other location in the country. It will incorporate and highlight smart, green, and resilient technology within its urban and industrial facilities, so it will be on the forefront of economic zone design. It is intended to directly compete on an international platform with top tier zones in China, South Korea and the Middle East. The vision for BSMSN, is as follows:

Strategically located 60 km from Chattogram, BSMSN will become the **'premier'** destination in a new economic corridor in Bangladesh – BSMSN – Chattogram – Mosheshkhali. As the 'flagship urban/industrial city' in Bangladesh, BSMSN will become the third largest and first comprehensively planned city in the country. BSMSN will be a smart city with a vibrant urban core and an innovative business hub, which will support international finance, commerce, and ITC. Surrounding the core, BSMSN will have residential, health, education and government precincts. In addition, BSMSN will have a dedicated industrial component, which will house light and medium industries, a port, and a separate heavy industrial area to support all types of warehousing/manufacturing/production activities within the zone.

BSMSN has been planned/designed to attract a variety of foreign and domestic investors and provide seamless, multi-transport/logistics (sea, air, road, rail) to support a broad range of industrial sectors and urban activities. BSMSN will be constructed with state-of-the art infrastructure and utilities, focusing on green technology and resilience measures to elevate the zone to an environmentally-friendly level, which tackles climate change and sustainability head on. The zone will spearhead new industry trends, sponsor value added production, and employ new cutting-edge technologies to put BSMSN at the forefront of 'excellence' around the world. In addition, the zone will offer a One-Stop Shop (OSS) with streamlined and fast-tracked services and after-care facilitation to its investors. BSMSN will allow an investor live, work and play in the city and be able to do business how and when they like, within a safe and secure environment. For Bangladesh, BSMSN will attract new investment opportunities, growth in exports, diversification in industry sectors, transfer of knowledge, and a variety of new exciting jobs for the local population.

To realize this vision and all its backward and forward benefits, the GoB must: i) stand firm on its commitment to prioritize and support this project, ii) honor the BSMSN concept, master plan and development guidelines, and iii) work with relevant stakeholders to seamlessly implement the economic zone so it becomes a world class zone. The GoB must also engage the private sector, civil society, and the

local community early on to keep them informed and updated on the development progress of BSMSN,<sup>3</sup> as their support for the project will be critically important.

## 2.4 The Value Proposition for BSMSN

A value proposition traditionally outlines the elements of a vision, which will attract/bring investors to the economic zone in the future. These elements help brand the zone and assist in identifying how the Master Plan should be designed/prepared.

The following is BSMSN's value proposition:

- BSMSN is the flagship, '**smart city/economic zone**' project for Bangladesh and a '**game changer**' in economic zone design and development.
- To be the premier, international work, live, play location and an urban/industrial hub in South Asia.
- Strategically located for easy access to domestic and international markets.
- Offering a multi-modal transport and logistics platform incorporating a port, rail, roads and airport connectivity to reduce congestion, delays, costs and increase efficiencies as well as strengthen supply chains.
- Spearheading state-of-the-art, green and resilient infrastructure, utilities and technology to make BSMSN competitive, efficient, sustainable and resilient.
- Targeting innovative foreign and domestic investors.
- Promoting exports, clean industry/manufacturing, value addition production utilizing cutting-edge technology, and supporting new industry trends and enhanced creativity.
- Aids in transferring knowledge, technology and innovation to local entrepreneurs, professionals and workers
- Offering a safe and secure environment, which is monitored on a 24/7 basis for investors, residents, workers, and visitors
- Offering an OSS with streamlined and fast-tracked processes and procedures as well as after-care facilitation
- Offering a competitive labour pool with new types of professional, technical, skilled and unskilled jobs for Bangladeshi

## 2.5 The Structure Plan for BSMSN

A Structure Plan is a planning tool, which examines and highlights the existing opportunities and constraints of a development site within the context of its surrounding region. The Structure Plan is an important part of any master plan process as it allows planners to study current development issues in a comprehensive manner - at the regional and site-specific level -, in order to rectify constraints, weaknesses

<sup>3</sup> A communication program for BSMSN stakeholders and the community should be introduced.

and/or threats, as the new project is planned, designed and implemented.

### **2.5.1 The Regional Structure Plan for BSMSN**

Because the BSMSN project is so large and will be exceptionally impactful in a positive economic/social/environmental manner, it must be first examined in its regional context. Hence, the following is an overview of the key opportunities and constraints in the region:

#### **Key Opportunities**

- An opportunity to plan BSMSN within its larger context examining the development opportunities of the area of influence (10km radius surrounding BSMSN) and the Chars adjacent the site.
- An opportunity to introduce improved, multi-modal transport and logistics (road, rail, sea, air) to the area, which is intended to reduce congestion and improve linkages to existing national infrastructure and to Chattogram and beyond.
- An opportunity to introduce long-term, comprehensive regional planning in Bangladesh focusing on introducing smart, green and resilient technology to the region.
- An opportunity to upgrade/improve core infrastructure and utilities in BSMSN, the area of influence and the surrounding areas to enhance the living conditions/daily lives of the local communities and better connect the area.
- An opportunity to formalize and enhance investments and businesses outside BSMSN.

#### **Current Key Constraints**

- Comprehensive regional planning has not been prioritized to date.
- Access to the BSMSN site, areas of influence and adjacent Chars is difficult.
- Portions of the road along the waterfront - the Old Embankment Road - to Chattogram is missing and requires development. If connected, the BSMSN site could be better linked with the Chattogram airport, port, and rail.
- Paved roads, power, water, sewerage networks in the region (BSMSN and beyond) is limited.
- The regional area is often inundated with water during the monsoon season.
- The shipbuilding sector has a strong presence south of the BSMSN site.
- Roads leading to the Chattogram Port are congested.

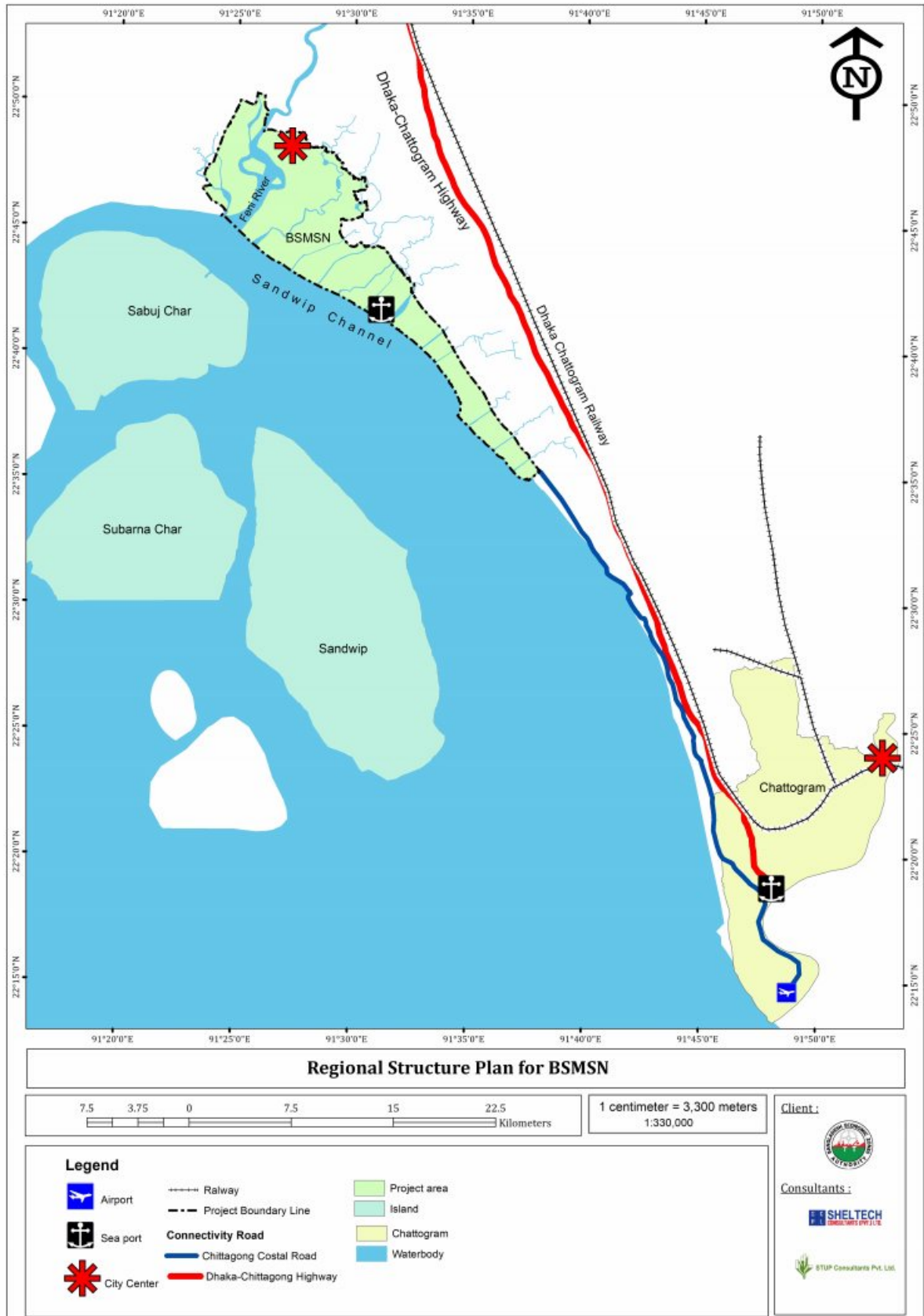

Figure 2-1: Regional Structure Plan for BSMSN

### 2.5.2 The BSMSN Site – Specific Structure Plan

The BSMSN Structure Plan examines the specific site and identifies its key opportunities and current constraints. By listing these elements, the issues can be addressed and rectified in the BSMSN Master Plan.

#### Key Opportunities

- The BSMSN is a greenfield site, which allows unlimited opportunities for development. It will be a mixed-use zone with large-scale industrial, commercial and residential potential and a live, work, play sustainable environment.
- An opportunity to provide and improve access into/out of BSMSN from the national Dhaka – Chattogram highway.
- An opportunity to separate industrial and vehicular traffic to reduce congestion and improve road safety within BSMSN.
- An opportunity to introduce a short, medium and long-term multi-modal transport plan for BSMSN. This plan will allow for transport right-of-ways to be protected, so long-term transport innovations like light rapid transit can be implemented in the future.
- An opportunity to provide a rail spur into BSMSN to support industry and the proposed port.
- An opportunity to connect BSMSN to Chattogram via the Old Embankment Road by building the 15 km of missing road and by bringing the rail within BSMSN along the waterfront to connect with Chattogram port, airport and railway station.
- An opportunity to upgrade the rail station near BSMSN to make it an efficient bus/rail transfer station for residents, workers or visitors.
- An opportunity to upgrade infrastructure and utilities to the site and introduce green and resilient technology and measures to make BSMSN environmentally-friendly, sustainable and able to withstand impacts from climate change.

#### Current Constraints

- Road and rail access into/out of the BSMSN site and connectivity to the char islands is currently limited.
- Core infrastructure is not yet available on the BSMSN site to support the future urban/industrial population.
- The BSMSN site needs to be significantly raised and protected from the impacts of the Bay of Bengal/climate change.
- The site is located in a sensitive area, which can be affected by natural disasters like floods, earthquakes and cyclones.
- A large portion of the site is covered with mangroves and/or forest.

- The site is vast and parts of it are difficult to reach because there are few internal roads within BSMSN.
- Not all the land for BSMSN has been acquired in order to implement a comprehensive Master Plan.
- There is a lack of water, power, and waste treatment facilities (solid, effluent, and water) within BSMSN.
- With shipbuilding to the south of the BSMSN site, only medium and heavier industries should be permitted in the southern end of the BSMSN site. This way there will not be any conflicting adjacencies.
- Some land within BSMSN has been allocated to investors before a comprehensive master plan has been legally adopted.

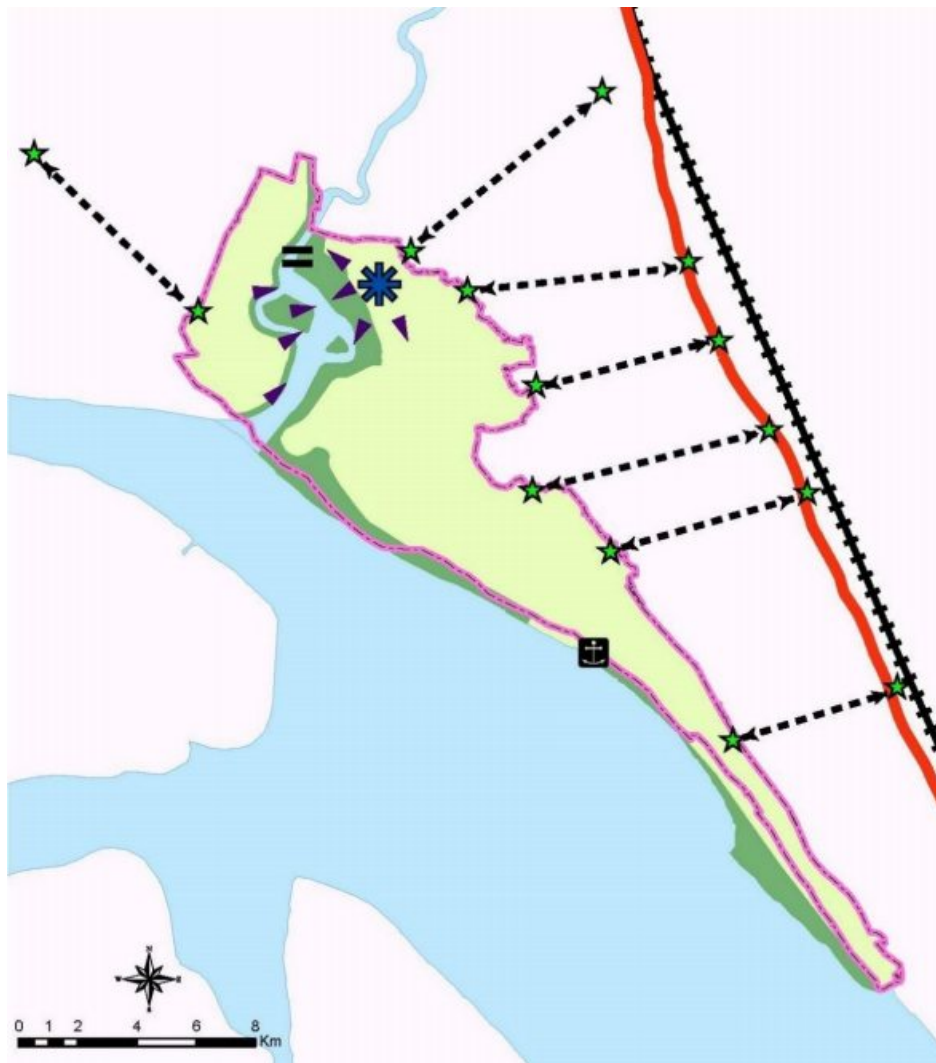

Figure 2-2 Site Structure Plan

## 2.6 Planning Principles for BSMSN

Planning principles are a set of statements derived from the Structure Plan analysis, which are developed to guide planning decisions for the BSMSN Master Plan. Although planning principles are stated in 'general terms', they are created to provide: i) consistency, ii) value for the project, and iii) economic growth for the region and country. The key planning principles for the site are:

- BSMSN is to be developed as a world-class city and one of the largest and most innovative urban/industrial areas in Bangladesh.
- BSMSN is to amalgamate the Feni and Mirsarai lands to create a single urban/industrial entity, which will have its own governance/management structure.
- BSMSN is to be developed within the context and consideration of its area of influence and surrounding water bodies.
- BSMSN is to be branded - Bold, Innovative and Competitive. The urban/industrial city will become a leading investment hub for the country.
- BSMSN is to be planned to attract the greatest mix of foreign, domestic and Tier 1 investors.
- BSMSN is to be comprehensively planned and strategically implemented, separating and buffering urban, residential, institutional, light and heavy industrial uses in order to mitigate inappropriate adjacencies and promote good development.
- BSMSN is to be an environmentally-friendly, green and resilient city, with a full array of land uses and supporting amenities to keep it vibrant and attractive to the largest group of investors, residents, workers and visitors.
- BSMSN is to be developed in a phased manner to optimize land and infrastructure/utility networks, reduce capital costs, and maximize the sustainability and viability of the urban/industrial city.
- BSMSN is to approve only high-quality real estate/industrial projects, developments and buildings to keep the zone's global competitiveness.
- BSMSN is to be constructed using international standards in order to create a dependable, safe, and secure environment.
- BSMSN is to be designed to incorporate beautifully planned, erected and maintained streetscapes (the public realm) with seasonal landscaping, public spaces, public art and street furniture to be used and enjoyed by the general population.
- BSMSN is to include a variety of parks and open spaces throughout the zone, which are well planned, designed and maintained in order to create a better quality of life for residents, workers and visitors.
- BSMSN is to be designed to create new jobs, transfer technology and support economic growth in Bangladesh and along the BSMSN – Chattogram - Mosheshkhali corridor.
- BSMSN is to have two resettlement areas near the boundary with the area of influence so relocated



households can remain close to their Feni and Mirsarai communities.

- Any area adjacent BSMSN and/or within the area of influence must be planned and developed using the planning principles, rules and regulations of BSMSN.

## 2.7 The BSMSN Master Plan

The Master Plan is a short, medium and long-term, comprehensive development plan for BSMSN, which prescribes how the urban/industrial city is intended to grow and expand over time. To support this master plan, guiding development policies have been prepared to reinforce the 'Planning Regime' for BSMSN. These policies follow the phasing section in this report. Master plan of BSMSN is shown in **Figure 2-3**.

### 2.7.1 Inputs into the Master Plan

The BSMSN Master Plan takes into account the: i) inputs from Reports Part I-III (specifically urban/industrial demand projections over a 20-year period), ii) vision and value proposition, iii) stakeholder and local community comments and recommendations, iv) regional and site-specific structure plan, and v) planning principles.

### 2.7.2 The Master Plan

The BSMSN Master Plan sets out: i) land uses, ii) access and transport networks, iii) precinct boundaries and characteristics, iv) zoning and permitted uses, v) development guidelines, and iv) environmental and green resilient rules to follow when implementing the zone. The BSMSN site has been divided into 12 separate precincts, which have their own land uses. Although specific plots have not been assigned in the master plan (except for within the industrial areas), it is intended that real estate projects following the designated/assigned land uses and design guidelines will be constructed over time and sold/leased at competitive market rates. The precincts, (their land use and size) for BSMSN are identified below.

*Table 2-1: BSMSN Precincts by Size*

No.	Precinct	Land Use Designation	Size in Acres
1.	A	Residential and Support Amenities	4,606.57
2.	B	City Center/Business Hub	1,732.91
3.	C	Health and Education Center	837.35
4.	D	Mixed Use/Residential	1,778.59
5.	E	Administrative/Institutional Center	880.68
6.	F	Light/Medium Industrial Area	10,043.12
7.	G	Port and Logistics Hub	1,802.29
8.	H	Forest/Transitional Area	1,778.75
9.	I	Heavy Industrial Area	3,956.35
10.	J	Open Space	5,980.42
11.	K	Leisure/Entertainment Area	350.89
12.	L	Cultural Center	56.85
<b>Total Area<sup>4</sup></b>			<b>33,804.76</b>

<sup>4</sup> As of October 2020.

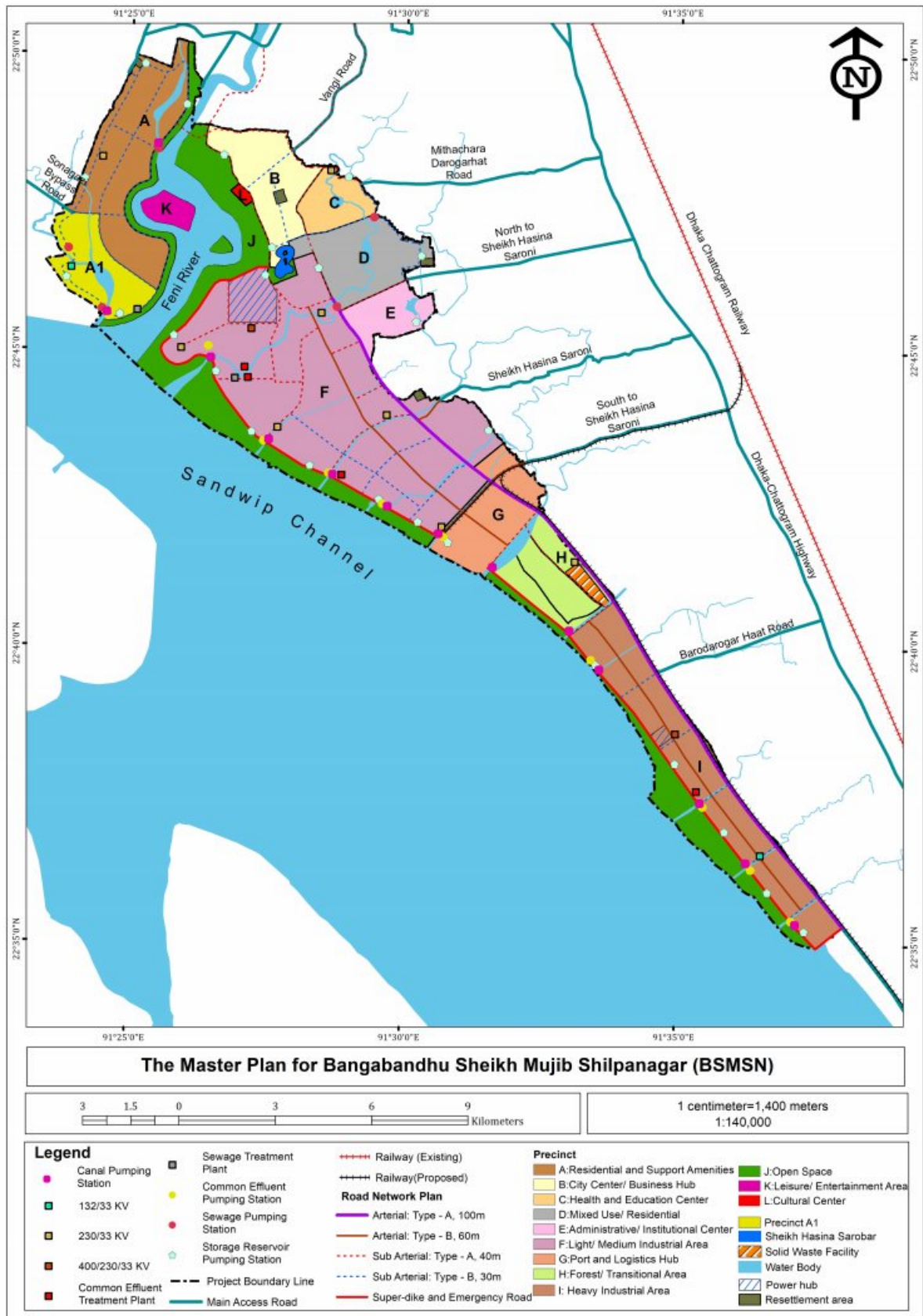

Figure 2-3: The Master Plan for Bangabandhu Sheikh Mujib Shilpanagar (BSMSN)

## 2.8 Land Uses for BSMSN

Land use designations for BSMSN are used to: i) guide short, medium and long-term development, ii) strengthen the vision and value proposition for the zone, iii) organize the activities within the site, iv) ensure/promote compatibility between land uses and sectors, v) limit adjacency and environmental issues/conflicts, vi) protect land values, and vii) promote economic growth.

### 2.8.1 Diverse Land Use Designations

BSMSN is comprised of a number of land use designations:

*Table 2-2: Precincts and Land Uses*

Precincts	Land Uses
<b>Residential and Support Amenities</b>	For low-scale residential units, convenience retail and educational/health uses.
<b>City Center/Business Hub</b>	For commercial, retail, administrative and technology/ICT related uses, high rise residential towers, and support amenities.
<b>Health and Education Centre</b>	For health clinics, hospitals, educational uses, support amenities, short-term residences/dormitories, hotels, and parking facilities.
<b>Mixed Use/Residential</b>	For low and medium residential typologies (apartments, dormitories, rowhouses etc.), support amenities, convenient retail, and the alike.
<b>Administrative/Institutional Center</b>	For government buildings, libraries, museums, galleries, shopping/retail, commercial facilities and support amenities etc.
<b>Light/Medium Industrial Area</b>	For light and medium industries, and a chemical hub only if buffered with landscaped boundaries.
<b>Port and Logistics Hub</b>	For port and logistics related activities and transport support amenities.
<b>Forest/Transitional Area</b>	For forest conservation purposes but transitional to port, logistics and/or heavy industrial uses, if required. Utility facilities are permitted.
<b>Heavy Industrial Area</b>	For heavy industrial uses and associated support amenities.
<b>Open Space</b>	For active and passive parks and open space. Limited development permitted.
<b>Leisure/Entertainment Area</b>	For a variety of leisure and entertainment uses and support amenities.
<b>Cultural Center</b>	For performing arts facilities, a cultural complex, sporting events, festivals, and large outdoor gatherings.

## 2.9 Precinct Plan for BSMSN

### 2.9.1 A Series of Distinct Precincts

Because of the size and complexity of the BSMSN site, the Master Plan has been divided into Precincts to better outline the: i) physical, ii) environmental and iii) social characters and qualities of each area within the plan.

Table 2-3: BSMSN Precincts by Percentage of Land

Precinct	Land Use	Size in %
A	Residential and Support Amenities	13.63
B	City Center/Business Hub	5.13
C	Health and Education Center	2.48
D	Mixed Use/Residential	5.26
E	Administrative/Institutional Center	2.61
F	Light/Medium Industrial Area	29.71
G	Port and Logistics Hub	5.32
H	Forest/Transitional Area	5.26
I	Heavy Industrial Area	11.70
J	Open Space	17.69
K	Leisure/Entertainment Area	1.04
L	Cultural Center	0.17
<b>Total Area</b>		100.00

The table above, sets out the BSMSN Precincts by name and the percentage of land within the zone, which they contain.

## 2.10 Precinct Descriptions/Development Guidelines

The following is a detailed overview of each Precinct within BSMSN. It prescribes the: i) vision, ii) value proposition, iii) land use designation, iv) zoning, and v) special features of the Precinct. These development guidelines along with the environmental and green/resilient guidelines adopted by BEZA will ensure that the BSMSN zone is properly planned, designed and constructed in a coordinated manner, as well as maintains land values and promotes the development of high-quality buildings and environments throughout BSMSN. **Figure 2-4** Shows 12 precincts of BSMSN.

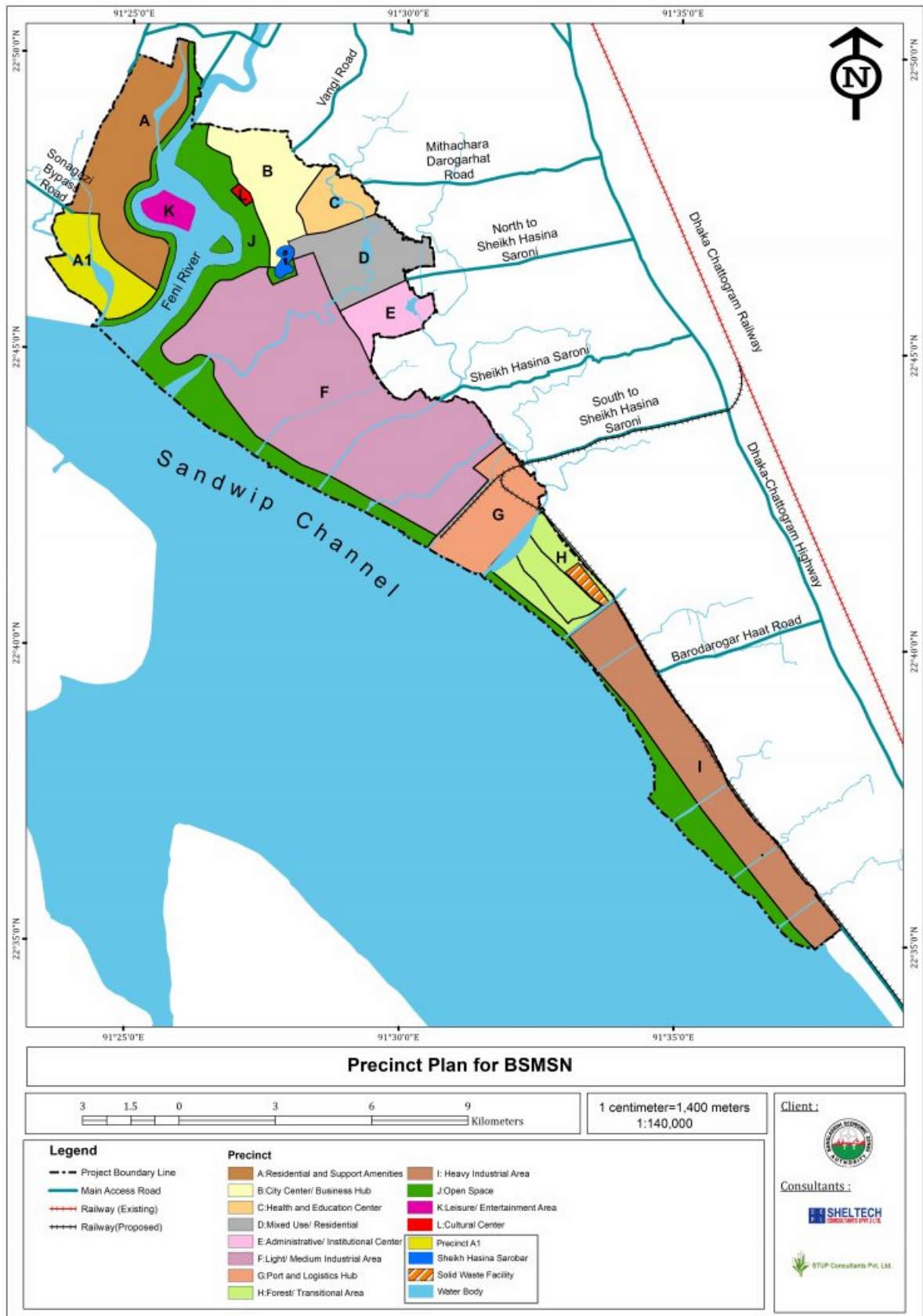

Figure 2-4: Precinct Plan for BSMSN

### 2.10.1 Precinct A: Residential and Support Amenities

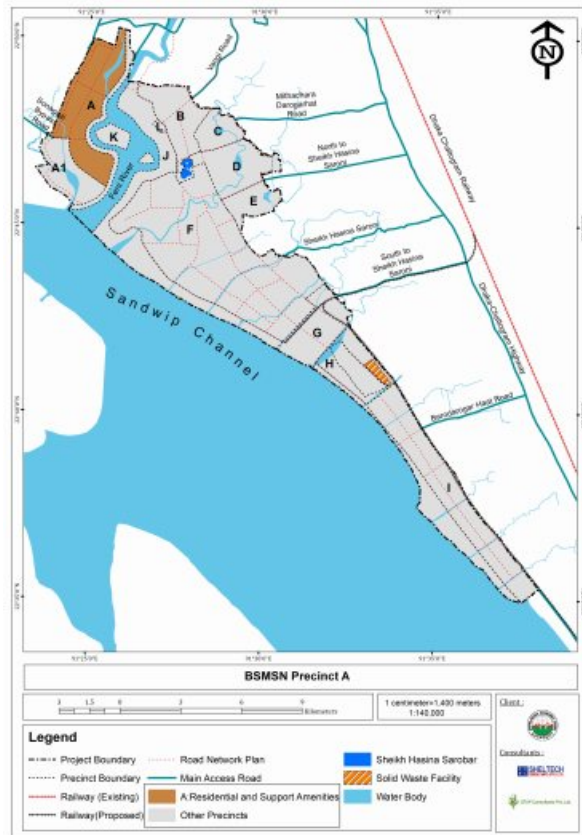

Figure 2-5: BSMSN Precinct A

#### a. Vision Overview

The vision for Precinct A is:

An urban oasis adjacent the downtown core of BSMSN. The precinct is comprised of eco-friendly residential neighbourhoods incorporating lush landscaping and natural water features. To support the residents of the neighbourhoods, small health clinics, primary and secondary schools, shopping, convenient retail, and entertainment/leisure areas will be strategically located in the precinct to support daily living. At the southern part of Precinct A, is Precinct A1 (Area 1460 acres out of 4,606.57 acres of precinct A), which is a high rise, mixed-use residential community, which is strategically located to optimize the views of the Sandwip Channel and Bay of Bengal.

#### b. Value Proposition

The value proposition is:

- Precinct A is minutes from the central business district/technology hub of BSMSN. It is easily accessed via a new bridge connecting Precincts A and B. There are superb views of the downtown core

from Precinct A. Precinct A also has a direct access route to the Chattogram Highway.

- Precinct A will have linear green space along the waterfront for the public and residents of BSMSN to enjoy. To be planned with passive and active green/landscaped areas with water features and urban design features. Will be developed with resilience and sustainability in mind.
- A mix of international housing typologies will be introduced in Precinct A - from villas and boutique housing for mid-senior management, foreign investors and corporations to low-rise apartment buildings with affordable units. All residential designs/construction will be focused on introducing/using green technology and resilience attributes to make the neighbourhoods smart, modern and sustainable.
- Precinct A will have appropriate facilities and amenities such as educational/health/retail/entertainment to support the neighbourhoods, which are in close proximity.
- Precinct A's neighbourhoods will incorporate water bodies/features and be heavily landscaped to pay tribute to the origins of the site.
- Precinct A will have a main arterial road around the perimeter of the precinct to ensure that traffic runs smoothly and so the neighbourhoods stay quiet and unaffected by traffic.

- Precinct A will have a direct access to Precinct J, which is a self-contained eco-entertainment/leisure centre.

### c. Land Use Designation

The main land use for Precinct A is:

- Residential

### d. Zoning

Precinct	Street R.O.W. (Width)	Storeys	Height (m)	Ground Floor Coverage (Percent)	Front Yard Setback (m)	Min. Side Yard Setback (m)	Min. Rear Yard Setback (m)	Landscaped Open Space (Percent)
A Residential and Support Amenities	20m	3	10.5	60%	10	5	5	30%
	30m	4	13.5	60%	10	5	5	30%
	40m	4	13.5	60%	10	5	5	30%

The permitted uses for Precinct A are:

- A variety of international housing typologies (single family houses, villas, duplexes, boutique apartments/hotels, green apartment buildings). Densities and height limits in this Precinct are lower than other areas of the urban/industrial city/zone.
- An appropriate amount of convenient retail/restaurants/shopping/leisure facilities to support Precinct A residents.
- Primary and secondary schools to support the residential mix.
- Health clinics and small medical facilities to support Precinct A's community but not compete with Precinct C.
- All types of religious buildings/facilities as required, are permitted in Precinct A.
- Open space for passive or active activities is permitted in Precinct A. Formal restaurants and cafes etc, designed to open space guidelines, permitted in specific open space areas.
- Utility facilities appropriate for residential use are permitted in Precinct A as long as they are buffered by landscaped areas.

### e. Special Features

The special features of Precinct A are:

- A bridge connecting Precinct A to downtown core.
- Direct road access to/from the Chattogram Highway.
- From an upgraded BSMSN rail station, a bus system/route into Precinct A will be provided.
- Public open space along the waterfront of Precinct A for the enjoyment of residents and visitors.

- Ring road around the Precinct so neighbourhoods experience reduced traffic congestion and improved traffic flows.
- The Precinct will have 20m wide roads throughout for local traffic. Main or arterial roads may be 30m wide, if necessary. Through roads may be 40m wide.
- Streets will be tree lined with pedestrian and vehicular lighting and street furniture. A wayfinding system for signage will be developed specifically for Precinct A.
- Parking designed to minimize impacts on the Precinct.
- Views to the water (sea or water features) will be prioritized.
- The existing canals in Precinct A will be redesigned to create water features for the use of the residential communities. The canals will become lakes/creeks/water features but will also remain water catchment areas for the surrounding lands. Precinct A will be lushly landscaped and will incorporate a number of green/resilient initiatives.
- No land shall be allotted to any type of industry/manufacturing/production within Precinct A.
- Heavy vehicles and cargo transport are not permitted in Precinct A.
- All utility facilities are to be well landscaped and buffered from public view.
- All utility distribution networks are to be underground.

### 2.10.2 Precinct A1

- Precinct A1 will be a high rise, mixed use, residential community, which will have spectacular views of the sea and the rest of BSMSN.

#### a. Land Use Designation

The main land use for Precinct A1 is:

- Residential
- Retail at-grade

#### b. Zoning

Precinct	Street R.O.W. (Width )	Storeys	Height (m)	Ground Floor Coverage (Percent)	Front Yard Setback (m)	Min. Side Yard Setback (m)	Min. Rear Yard Setback (m)	Landscaped Open Space (Percent)
<b>A1 Residential (Area from Bay of Bengal to Arterial Road)</b>	20m	10	31.5	60%	5	5	5	30%
	30m	15	46.5	60%	5	5	5	30%
	40m	20	61.5	60%	5	5	5	30%



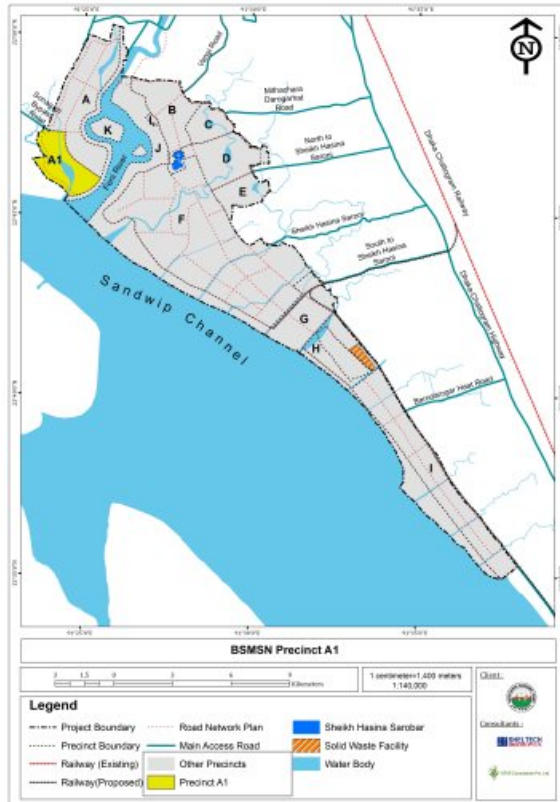

Figure 2-6 BSMSN Precinct A1

The permitted uses for Precinct A1 are:

- A variety of international, high-rise housing typologies. Densities and height limits in this Precinct are higher in this portion of Precinct A.
- An appropriate amount of convenient retail/restaurants/shopping/leisure facilities to support Precinct A1 residents.
- Health clinics and small medical facilities to support Precinct A1's community but not compete with Precinct C.
- All types of religious buildings/facilities as required, are permitted in Precinct A1.
- Open space for passive or active activities is permitted in Precinct A1. Formal restaurants and cafes etc, designed to open space guidelines, permitted in specific open space areas.

- Utility facilities appropriate for residential use are permitted in Precinct A1 as long as they are buffered by landscaped areas.
- Public open space along the waterfront of Precinct A1 for the enjoyment of residents and visitors.
- Ring road around the Precinct so the neighbourhood experiences reduced traffic congestion and improved traffic flows.
- The Precinct will have 20m wide roads throughout for local traffic. Main or arterial roads may be 30m wide, if necessary.
- Streets will be tree lined with pedestrian and vehicular lighting and street furniture. A wayfinding system for signage will be developed specifically for Precinct A1.
- Parking designed to minimize impacts on the Precinct.
- Views to the water (sea or water features) will be prioritized.
- The existing canals in Precinct A1 will be redesigned to create water features for the use of the residential communities. The canals will become lakes/creeks/water features but will also remain water catchment areas for the surrounding lands. Precinct A1 will be lushly landscaped and will incorporate a number of green/resilient initiatives.
- No land shall be allotted to any type of industry/manufacturing/production within Precinct A1.

- Heavy vehicles and cargo transport are not permitted in Precinct A1.
- All utility facilities are to be well landscaped and buffered from public view.
- All utility distribution networks are to be underground.

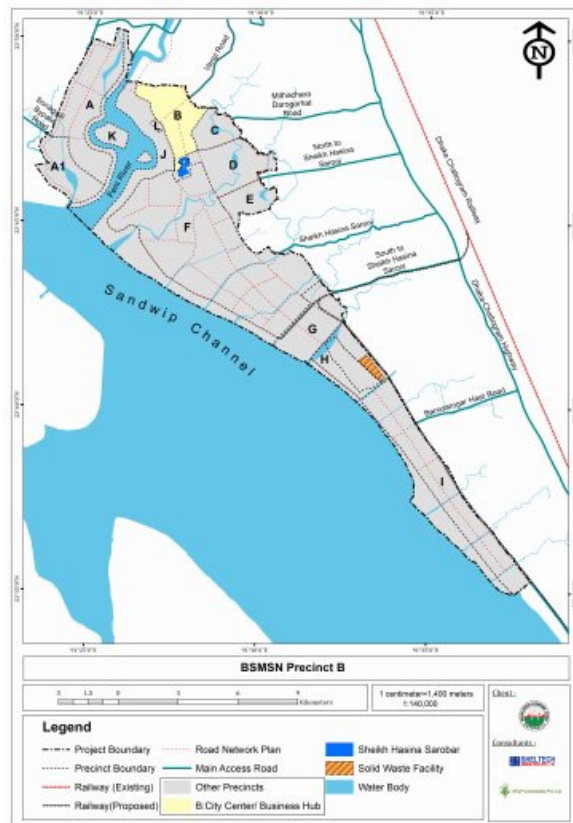

Figure 2-7: BSMSN Precinct B

### 2.10.3 Precinct B: City Center/Business Hub

#### a. Vision Overview

The vision for Precinct B is:

The vibrant, urban core/central business district of BSMSN. It is a world-class business and IT hub incorporating smart city/green/resilience technology to attract Tier 1 - foreign and domestic investors. Precinct B will be comprised of tall, architecturally significant, commercial buildings designed by leading architects from around the world. It will be an area of finance, technology, trade, services as well as home to a variety of Corporation's South Asian headquarters. In the future, Precinct B's skyline will be globally recognizable and will be synonymous with innovation, technology and progress. It is this Precinct, which will help change the image of Bangladesh from a low-cost manufacturing hub to a dynamic business/opportunity hub for international and domestic players from all sectors.

#### b. Value Proposition

The value proposition is:

- Precinct B will be designed to be the third largest city in Bangladesh and the first city in the country to be designed using smart city/green technology/resilience initiatives.
- Precinct B will be designed to take advantage of the unprecedented views of BSMSN and the sea.
- Precinct B will be an international business/IT hub for foreign and domestic investors offering state-of-the-art technology and facilities found nowhere else in South Asia. Also, Precinct B will be a business-friendly environment.
- Precinct B will have a green perimeter. This open space will have a mix of active and passive areas to be used by investors, visitors and residents of BSMSN. To the north, this allows for future expansion of Precinct B in the long-term, if required.
- Directly south of Precinct B is a green area, which will be a cultural hub with nationally important buildings such as a symphony/ballet hall and sports area. These architecturally distinct buildings

will be surrounding by well-designed green areas/hard and soft landscaping and large gathering areas for public use and enjoyment. Public events/festivals etc. will also take place in the area. This green area will also be resilient and sustainable.

- Precinct B has direct access to the Chattogram Highway and has an arterial road network, which surrounds the downtown core to reduce traffic congestion.
- Precinct B is adjacent to both a residential community (Precinct A) and a health and education hub (Precinct C).
- Precinct A will have a main arterial road around the perimeter of the precinct to ensure that traffic runs smoothly and so the neighbourhoods stay quiet and unaffected by traffic.
- A large, tree lined boulevard with a dedicated public transportation lane will link the downtown core with the rest of BSMSN and the other precincts.
- A large, public park will denote the southern border of Precinct B.

### c. Land Use Designation

The main land use designation for Precinct B is:

- Commercial/Retail/Services - Central Business District

### d. Zoning

Precinct	Street R.O.W. (Width)	Storeys	Height (m)	Ground Floor Coverage (Percent)	Front Yard Setback (m)	Min. Side Yard Setback (m)	Min. Rear Yard Setback (m)	Landscaped Open Space (Percent)
<b>B City Center/Business Hub</b>	20m	25	102	80%	0	0	5	20%
	30m	30	122	80%	0	0	5	20%
	40m	50	202	80%	0	0	5	20%

The permitted uses in Precinct B are:

- Commercial (financial, banking, business, services, trade, IT facilities, hotels or similar).
- Retail (convenient retail, restaurants, main street shopping, retail/wholesale stores or similar).
- Entertainment (cinemas, play and innovation centres, art galleries or similar).
- Social services (business centres, incubators, libraries, or similar).
- All types of religious buildings/facilities are permitted in Precinct B.
- Open space for passive or active activities are permitted within specific areas of Precinct B.

### e. Special Features

The special features for Precinct B are:

- Creation of an architecturally distinct skyline within Precinct B, which will make BSMSN globally recognizable.
- Monumental architecture utilized in Precinct B.
- Business friendly environment is critically important in Precinct B.
- A Precinct with state-of-the-art technology, green infrastructure/buildings, and a resilient design.
- All utility distribution networks are underground in Precinct B..
- Tree-lined streets, pedestrian lighting, international signage, inspiring views, and well- defined open spaces and public gathering areas.
- Parking designed to minimize impacts on the Precinct.
- Direct connection to cultural hub south of the core.
- Easy access to/from the Chattogram Highway.
- From an upgraded BSMSN rail station, a bus system/route into Precinct B will be provided.
- No land shall be allotted for any type of industrial activity within Precinct B.
- Heavy vehicles or cargo transport shall not be permitted in Precinct B.

#### **2.10.4 Precinct C: Health and Education Centre**

##### **a. Vision Overview**

The vision for Precinct C is:

An international health and education centre for BSMSN and Bangladesh. It will contain international-level hospitals, universities, primary/secondary schools, research and development facilities, international schools, and appropriate medical and educational support services/facilities to make Precinct C the country's foremost health, wellness, and education centre. Precinct C will be designed as an integrated complex with state-of-the-art technology, significant amounts of open/landscaped space and areas for social gatherings/intellectual exchanges.

##### **b. Value Proposition**

The value proposition is:

- Precinct C is strategically located between the downtown core (Precinct B) and the largest, mixed-use residential area (Precinct D) on the BSMSN site.
- Precinct C supports the country's newest international medical and educational facilities, making BSMSN the most attractive location for foreign investment in Bangladesh because of its world-class support facilities and amenities.

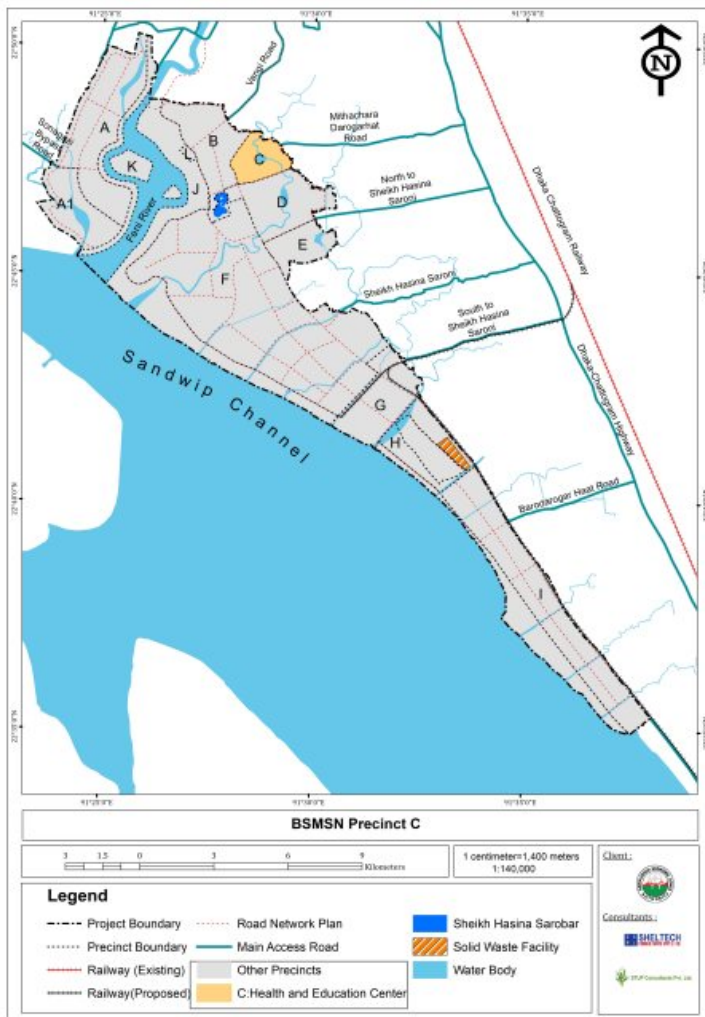

Figure 2-8: BSMSN Precinct C

- Precinct C will use smart city/green technology and incorporate high tech/resilient infrastructure/utilities.
- The universities and health facilities should be twinned with international health and educational facilities around the world.
- Precinct C will also have direct access to the Chattogram Highway as well as views of the Bay of Bengal and the rest of BSMSN.
- Precinct C will have a number of health and educational facilities designed to create campuses with landscaped areas where academics and professionals can relax, be inspired, and meet to interact and share/nurture ideas.
- Precinct C will have training facilities for business and vocational colleges/training for industry.

- Precinct C will have appropriate support facilities and amenities such as convenient retail/restaurants/entertainment areas as well as the open spaces.
- Precinct C will incorporate water bodies/features to help create the serene/innovative/thought provoking environments.
- The Precinct will be walkable with some 20m wide roads throughout for vehicle access
- Precinct C will be accessible from the main boulevard of BSMSN, which has a dedicated bus lane and a number of bus routes leading throughout the site.

### c. Land Use Designation

The main land use designations for Precinct C are:

- Health and Education

#### d. Zoning

Precinct	Street R.O.W. (Width)	Storeys	Height (m)	Ground Floor Coverage (Percent)	Front Yard Setback (m)	Min. Side Yard Setback (m)	Min. Rear Yard Setback (m)	Landscaped Open Space (Percent)
<b>C Health and Education Centre</b>	20m	4	18	70%	5	3.5	5	20%
	30m	5	22	70%	5	3.5	5	20%
	40m	6	26	70%	5	3.5	5	20%

The permitted uses for Precinct C are:

- Health facilities. This includes international level hospitals, research and wellness labs/clinics/facilities, doctor's offices, or similar.
- Educational facilities. This includes international level schools (primary/secondary), universities, training facilities, vocational colleges, or similar.
- Housing. Short term housing/hotels/dormitories are permitted to support health care and educational facilities.
- An appropriate amount of convenient retail/shopping/leisure facilities to support Precinct C.
- All types of religious buildings/facilities are permitted in Precinct C.
- Landscaped/resilient open space for passive or active activities are permitted in Precinct C.
- Auxiliary utility facilities are permitted in Precinct C, if required to support health/educational uses.

#### e. Special Features

The special features of Precinct C are:

- Campus type setting of Precinct C sets up a creative environment, limits roads/traffic and allows for greater pedestrian movement and larger, dynamic gathering spaces.
- Parking designed to minimize impacts on the Precinct.
- The existing canals in Precinct C will be redesigned to create lakes/creeks/water features and expansive landscaped, green open space areas to help promote synergizes between the health and educational facilities.
- Arterial road networks with bus transportation to service all areas of BSMSN.
- Direct access to/from the Chattogram Highway.
- From an upgraded BSMSN rail station, a bus system/route into Precinct C will be provided.
- No industrial activities are permitted in Precinct C.

- No trucks or cargo transport is permitted in Precinct C.
- All utility distribution networks are underground in Precinct C.

### 2.10.5 Precinct D: Mixed Use/Residential

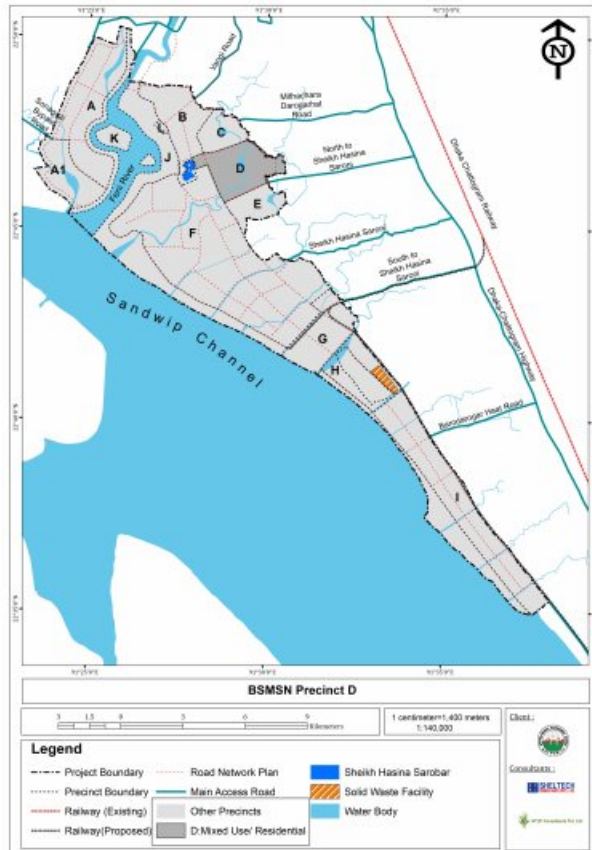

Figure 2-9: BSMSN Precinct D

#### a. Vision Overview

The vision for Precinct D is:

A mixed-use, residential area comprised of a variety of modern, international level, high-rise apartment buildings with at-grade retail/restaurants. The streets will be tree-lined, landscaped with pedestrian lighting and street furniture, with a wayfinding signage system throughout. Open space/parks will be regular features of the residential neighbourhoods with a large park at the south end of the Precinct.

#### b. Value Proposition

The value proposition is:

- Precinct D is in close proximity to Precincts B, C and E and appropriately linked by the road network and bus system in order to conveniently access the all areas of BSMSN, including the industrial locations. This allows international investors, professionals and factory workers to reside in this strategic residential location.

- A variety of medium and high-rise apartment buildings will be present in this Precinct to support the needs of all residents of BSMSN. All buildings will have retail at-grade, as well as views of the larger site and the Bay of Bengal.
- The existing canal system will be upgraded, re-enforced and landscaped to support the resilience of the Precinct. Water bodies/features will be an integral part of the Precinct D design.
- Precinct D will have appropriate facilities and amenities such as small scale, convenient retail/restaurants/shopping/entertainment facilities to support the residential community.
- Precinct D will have a large park on its southern boundary, which will also denote the entry to the City Centre.
- Precinct D will have 20m roads within to minimize the vehicular traffic in the neighbourhoods and a larger 30m arterial roads surrounding the Precinct to aid the flow of traffic and reduce congestion.
- Precinct D will have a shared access to the Chattogram Highway.

### c. Land Use Designation

The main land use designation for Precinct D is:

- Mixed-Use/Residential

### d. Zoning

Precinct	Street R.O.W. (Width)	Storeys	Height (m)	Ground Floor Coverage (Percent)	Front Yard Setback (m)	Min. Side Yard Setback (m)	Min. Rear Yard Setback (m)	Landscaped Open Space (Percent)
<b>D Mixed Use/Residential</b>	20m	8	26.5	70%	0	3.5	5	20%
	30m	12	39	70%	0	3.5	5	20%
	40m	15	48	70%	0	3.5	5	20%

The permitted uses within Precinct D are:

- A variety of international housing typologies (medium/high apartments or similar)
- An appropriate amount of convenient retail stores/restaurants/banking to support the mix of Precinct D residents.
- Primary and secondary schools to support the residential mix.
- Doctor's offices/health clinics to support Precinct D but not compete with Precinct C.
- All types of religious buildings/facilities are permitted in Precinct D.
- Open space for passive or active activities are permitted in Precinct D.

### e. Special Features

The special features for Precinct D are:

- A number of mixed-use, residential neighbourhoods with views constructed to international standards.
- Tree-lined streets, pedestrian lighting, street furniture, and wayfinding signage.
- Large and small public open spaces/parks/landscaped canals for active and passive use.
- Sports facilities for residents/visitors.
- All utility distribution networks are underground in Precinct D.
- Parking designed to minimize impacts on the Precinct.
- Arterial road network surrounding the Precinct with smaller interior roads.
- Shared access to/from the Chattogram Highway.
- From an upgraded BSMSN rail station, a bus system/route into Precinct D will be provided.



- No industrial activities are permitted in Precinct D.
- No trucks or cargo transport is permitted in Precinct D.

### 2.10.6 Precinct E: Administrative/Institutional Centre

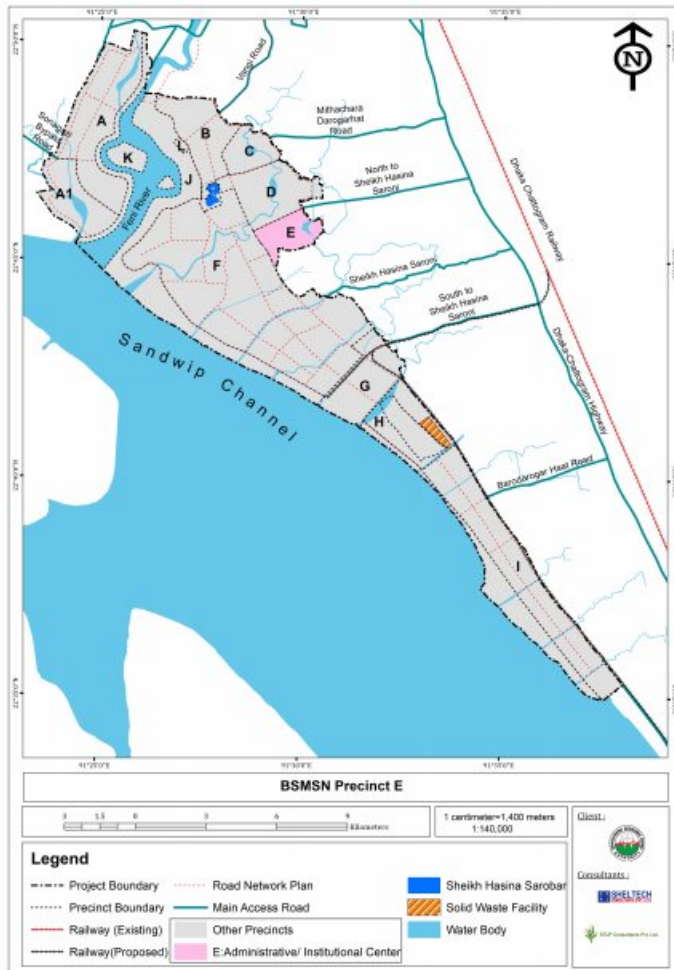

Figure 2-10: Precinct E of BSMSN

- Precinct E is adjacent the mixed-use residential community (Precinct D) and in close proximity to the health and educational area (Precinct C) as well as the City Centre (Precinct B). It will also overlook the light industrial area of BSMSN (Precinct F).
- Precinct E will have views of the Bay of Bengal and the rest of BSMSN.
- Precinct E will house all the institutional/administrative buildings in BSMSN, including BEZA offices and support facilities.
- Precinct E will also contain the main shopping centre in BSMSN as well as all the national public buildings.
- Precinct E will host festivals, events and will contain public gathering space and park land.

#### a. Vision Overview

The vision for Precinct E is:

The institutional/administrative centre of BSMSN. It is located adjacent the main entryway into BSMSN and contains all government and BEZA buildings/offices as well as, support services and amenities for the project. The Precinct features monumental and stately structures featuring large public gathering spaces, parks, fountains, meandering walkways and hard/soft landscaping. The Precinct also supports the major shopping/retail area for BSMSN as well as public buildings such as museums, art galleries, libraries etc.

#### b. Value Proposition

The value proposition is:

- Precinct E will have direct access from the main road into BSMSN, which leads from the Chattogram Highway.

- The interior road system within Precinct E will be based on a 20m wide network with arterial roads being 30m wide to help control congestion.

### c. Land Use Designation

The main land use designation for Precinct E is:

- Institutional/Administration

### d. Zoning

Precinct	Street R.O.W. (Width)	Storeys	Height (m)	Ground Floor Coverage (Percent)	Front Yard Setback (m)	Min. Side Yard Setback (m)	Min. Rear Yard Setback (m)	Landscaped Open Space (Percent)
E Administrative /Institutional Centre	20m	4	18	60%	10	5	5	30%
	30m	6	26	60%	10	5	5	30%
	40m	10	42	70%	10	5	5	30%

The permitted uses within Precinct E are:

- All government and public buildings (offices for Government of Bangladesh/BEZA or similar).
- Museums, art galleries, cultural facilities, theatres or similar.
- Main shopping and entertainment centre for BSMSN. (retail shopping centre, cinemas, entertainment facilities or similar.)
- Support facilities such as convenient retail, restaurants, banking or similar.
- All types of religious buildings/facilities are permitted in Precinct E.
- Open space for passive or active activities are permitted in Precinct E.

### e. Special Features

The special features of Precinct E are:

- Direct access to/from the Chattogram Highway.
- From an upgraded BSMSN rail station, a bus system/route into Precinct E will be provided.
- Location of all public buildings and offices for BSMSN.
- The main shopping centre and entertainment facilities for BSMSN.
- All utility distribution networks are underground in Precinct E.
- Public parks and gathering spaces are a key element of this Precinct.

- Parking designed to minimize impacts on the Precinct.
- No industrial activities are permitted in Precinct E.
- No trucks or cargo transport is permitted in Precinct E.

### 2.10.7 Precinct F: Light/Medium Industrial Area

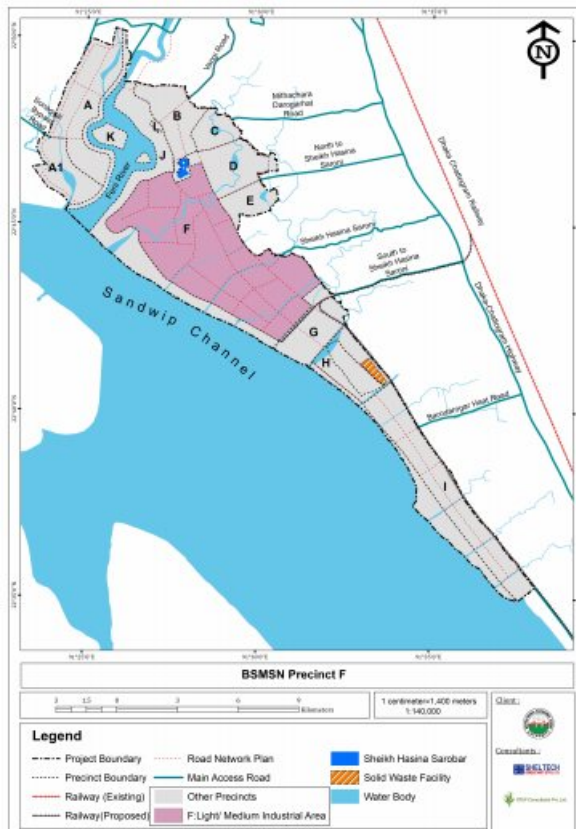

Figure 2-11: BSMSN Precinct F

#### a. Vision Overview

The vision for Precinct F is:

The light industrial area of BSMSN. It is intended to house only light and medium industry sectors in order to properly separate, buffer and protect the area from heavier, more polluting industries. The Precinct will be constructed to international standards, ensuring proper truck/cargo movements and easy access to arterial roads leading in and out of BSMSN. The area will be designed to provide state-of-the-art infrastructure and utility networks, which are eco-friendly, sustainable and resilient.

#### b. Value Proposition

The value proposition is:

- Only light and medium industrial projects (manufacturing, processing, warehousing etc.) is permitted in Precinct F to ensure compatible development.

- Precinct F will have direct access from the main road into BSMSN, which leads from the Chattogram Highway.
- Automated/digital customs will be available within Precinct F.
- Precinct F will have a tiered road network (public roads 100m, 80m, and 40m wide) and 30m and 20m roads within industrial investment projects.
- All roads within Precinct F will have tree-lined sidewalks.
- Precinct F will be designed with eco-friendly/resilient infrastructure/utility networks specifically for light and medium industries. All infrastructure/utilities will be integrated under the road sidewalks.
- The existing canal system will be upgraded, expanded and lined to comprehensively channel the water from the region through the Precinct into the Bay of Bengal. In public areas, these canals will be sustainably landscaped.

- Large areas of land will be available for private or Government to Government developers/operators.

### c. Land Use Designation

The main land use designation for Precinct F is:

- Light/Medium Industrial

### d. Zoning

Precinct	Street R.O.W. (Width)	Storeys	Height (m)	Ground Floor Coverage (Percent)	Front Yard Setback (m)	Min. Side Yard Setback (m)	Min. Rear Yard Setback (m)	Landscaped Open Space (Percent)
<b>F</b>	20m	2	9.5	70%	5	3.5	3.5	20%
<b>Light/ Medium Industrial Area</b>	30m	3	13.5	70%	10	3.5	5	20%
	40m	3	13.5	70%	10	3.5	5	20%

The permitted uses within Precinct F are:

- Only light and medium industries, which cause minimal pollution and require a clean environment.
- Limited support facilities such as convenient retail, restaurants, banking or similar in designated areas.
- All types of religious buildings/facilities are permitted in designated areas.
- Open space for factory employees is mandatory in designated areas.
- Utility facilities to support the industrial areas.

### e. Special Features

The special features for Precinct F are:

- Direct access into Precinct F from the Chattogram Highway.
- From an upgraded BSMSN rail station, a bus system/route into Precinct F will be provided.
- Precinct F will provide a bus system to deliver workers to their factories.
- Only available for light and medium industries.
- Core infrastructure/utility networks designed to be eco-friendly, sustainable, and resilient.
- Support amenities and open space provided for industry workers in designated areas.
- Focus on implementing/ integrating green technology into the Precinct.
- Customs will be available 24/7 within Precinct F to support all investors.

**f. Special Environmental Guidelines**

The following are special environmental guidelines for Precinct F:

- No heavy industry, (chemical, hazardous, or polluting factories/businesses) are permitted in Precinct F.
- The existing chemical hub and all heavy industry must be properly buffered from all Precincts. The park land adjacent the chemical hub must contain a large lake to store water to mitigate any unforeseen fires or hazardous occurrences. No buildings such as residence, hotels, museums, performing arts/sports facilities are permitted within the associated parkland. This park space is a buffer between the chemical hub and Precincts B, C, D, and E.
- All utilities such as Gas Plants, Water/Wastewater Treatment Plants, Effluent Treatment Plants or alike must be properly buffered/landscaped from the streetscape. A minimum planted setback of 10m must be provided from the street.
- All light/medium industry’s truck/cargo transport is required to use the truck route/spine within BSMSN.

**2.10.8 Precinct G: Port and Logistics Hub**

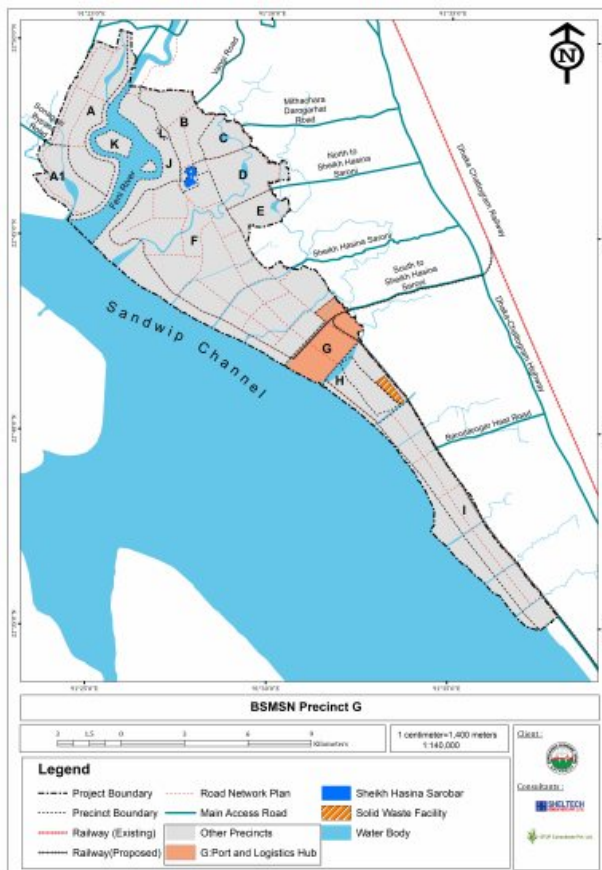

Figure 2-12: BSMSN Precinct G

**a. Vision Overview**

The vision for Precinct G is:

The port and logistics hub within BSMSN. The Precinct will be designed as a multi-modal, transport platform to provide improved logistics for the country. Precinct G will have a new port and a special access road to/from the Chattogram Highway in order to better facilitate trucks and separate cargo/vehicular traffic. Precinct G will also have a rail spur from the main line railway line adjacent the Chattogram Highway. In the future, an additional railway line will be available from BSMSN directly to the Port of Chittagong and the Chittagong International Airport along the waterfront of the Bay of Bengal. All industrial tenants of BSMSN will be able to utilize these port and logistics facilities.

**b. Value Proposition**

The value proposition is:

- Precinct G will be a multi-modal, transport platform – road, rail, sea, and air.
- Precinct G will have a new port, direct access/connectivity to/from the Chattogram Highway, and a rail spur to connect to two railway lines, which stretch north to Sylhet/Dhaka and south to Chittagong.
- Precinct G is bounded by 100 m wide road to assist in the movement of goods on/off BSMSN.
- Synergies will be aligned between the port, the logistics hub and the light and heavy industrial areas within BSMSN, which will help reduce costs and increase transport, supply chain and distribution efficiencies.
- The port in BSMSN will be public so all tenants will have the opportunity to utilize it, if required.

### c. Land Use Designation

The main land use designation in Precinct G is:

- Port/Logistics

### d. Zoning

Precinct	Street R.O.W. (Width)	Storeys	Height (m)	Ground Floor Coverage (Percent)	Front Yard Setback (m)	Min. Side Yard Setback (m)	Min. Rear Yard Setback (m)	Landscaped Open Space (Percent)
<b>G Port and Logistics Hub</b>	N/A	5	21.5	TBD	TBD	TBD	TBD	10%

- To be determined by a feasibility study

The permitted uses within Precinct G are:

- All port and logistics facilities or similar. IE. Bulk or container. Hazardous goods are not permitted.
- Port/Logistics hub headquarters building or similar.
- Customs/stevedore facilities.
- Maintenance facilities/operating buildings.
- Paved open areas for storage of cars, cargo, materials or similar.
- Factories for warehousing, storage, cold storage, distribution, pick or packing, labelling, or similar.
- Open warehouses or similar.
- Rail station/loading facilities or similar.

### e. Special Features

The special features of Precinct G are:

- Direct road/rail access into Precinct G from the Chattogram Highway.
- Future rail/people mover/light rail transit link to Chittagong along Bay of Bengal.
- New port and logistics hub for all tenants of BSMSN.
- Improvement of port and logistics services/facilities in the region.
- Utility hub in close proximity to Precinct G.

#### **f. Special Environmental Guidelines**

The special environmental guidelines for Precinct G are:

- No heavy industry, (chemical, hazardous, or polluting factories/businesses) are permitted in Precinct G.
- The existing chemical hub and all heavy industry must be properly buffered from all Precincts. A minimum, 20m landscaped buffer is required.
- All utilities such as Gas Plants, Water/Wastewater Treatment Plants, Effluent Treatment Plants or alike must be properly buffered/landscaped from the streetscape. A minimum planted setback of 5m must be provided from the street.
- All light/medium industry's truck/cargo transport is required to use the truck route/spine within BSMSN.

**2.10.9 Precinct H: Forest/Transitional Area: Additional Port/Logistics**

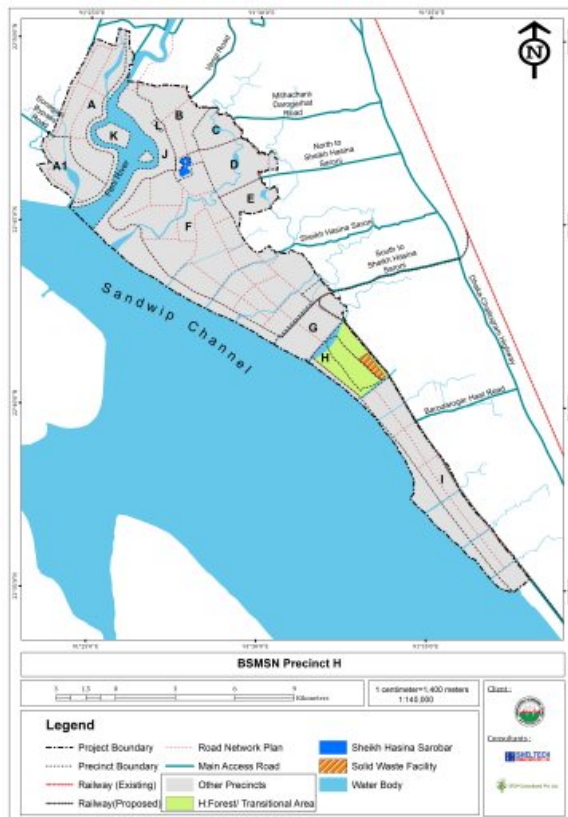

Figure 2-13: BSMSN Precinct H

**a. Vision Overview**

The vision for Precinct H is:

A forest conservation area, where development in the short term is currently not permitted. It is comprised of mangroves and similar plant material, which must remain – in accordance with the Forest Department. In the near future however, this site could become a port/logistics or heavy industrial area depending upon demand within BSMSN.

**b. Value Proposition**

The value proposition for Precinct H is:

In the short term, this Precinct is to remain undeveloped. However, in the medium to long-term, the Precinct could be an extension of Precinct’s G or I.

**c. Land Use Designation**

The main land use designations for Precinct H are transitional:

- Forest Conservation/Transitional Lands – Short-Term
- Port and Logistics/Heavy Industrial – Medium to Long-Term

**d. Zoning**

Precinct	Street R.O.W. (Width h)	Storeys	Height (m)	Ground Floor Coverage (Percent)	Front Yard Setback (m)	Min. Side Yard Setback (m)	Min. Rear Yard Setback (m)	Landscaped Open Space (Percent)
<b>H*</b> <b>Forest/Transitional Area</b>	20m	0/5	0/21.5	0/70%	0/5	0/3.5	0/3.5	20%
	30m	0/6	0/25.5	0/70%	0/10	0/3.5	0/5	20%
	40m	0/6	0/25.5	0/70%	0/10	0/3.5	0/5	20%

\*First number is short-term. Second number is mid to long-term development limits.

The permitted uses on Precinct H are transitional:

- No industrial development is permitted in this Precinct in the short term unless approved by BEZA and the Department of Forests.
- Port and logistics related uses are permitted in the medium to long-term.
- Utility facilities are permitted as long as they are grouped/clustered together.



- Permitted uses are the same as Precinct G.

### 2.10.10 Precinct I: Heavy Industrial Area

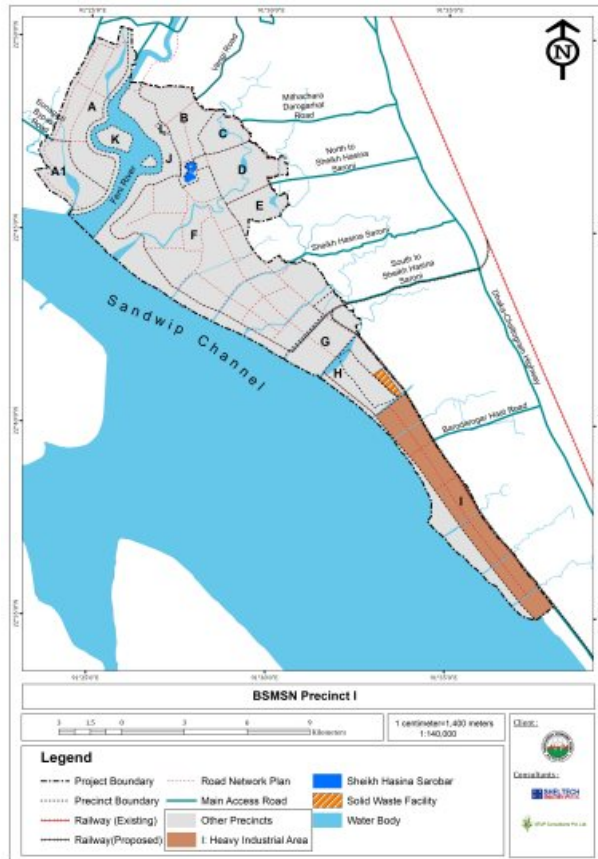

Figure 2-14: BSMSN Precinct I

#### a. Vision Overview

The vision for Precinct I is:

The heavy industrial area within BSMSN. It houses the larger industries, which tend to create higher pollution, consume greater amounts of energy and require additional utility systems to mitigate their waste and water. Precinct I will be specially designed for these types of industries and will utilize modern/ resilient technology to mitigate impacts.

#### b. Value Proposition

The value proposition is:

- Precinct I will be designed specifically for heavy industry and will be the location within BSMSN for polluting sectors.
- Precinct I will have access to/from the Chattogram Highway via public, arterial road networks within BSMSN, which are 80-100m in width to support large trucks and heavy cargo loads and movements.

- Special infrastructure and utilities will be constructed within Precinct I to minimize negative impacts on other heavy industries or within BSMSN.

#### c. Land Use Designation

The main land use designation for Precinct I is:

- Heavy Industry

#### d. Zoning

Precinct	Street R.O.W. (Width)	Storeys	Height (m)	Ground Floor Coverage (Percent)	Front Yard Setback (m)	Min. Side Yard Setback (m)	Min. Rear Yard Setback (m)	Landscaped Open Space (Percent)
<b>I Heavy Industrial Area</b>	20m	5	21.5	70%	5	3.5	3.5	20%
	30m	6	25.5	70%	10	3.5	5	20%
	40m	6	25.5	70%	10	3.5	5	20%

The permitted uses within Precinct I are:

- Limited heavy industry (cement, iron/steel, chemicals, fertilizer, minerals, paints or similar) except for hazardous, explosive or dangerous sectors/activities.
- Support offices/facilities for the above.
- Convenient retail/restaurants in designated areas.
- Religious facilities in designated areas.
- Plots must be significantly buffered to limit the exposure of the heavy industries. The plots must have landscaping around its plot boundaries.
- Landscaped open space for workers.
- Utilities are permitted in this area.

#### e. Special Features

The special features within Precinct I are:

- Direct access into Precinct I from the Chattogram Highway.
- Heavy industry is clustered to minimize environmental conflicts with light and medium industries.
- Large arterial roads (60-100m in width) within Precinct I to support transport requirements of heavy industry.
- Landscaped buffer areas surrounding plots to mitigate pollution.
- Specialized infrastructure/utility networks to support heavy industry.
- Larger plots to facilitate the needs of heavy industries and loading requirements.
- Utilities are to be buffered with landscaping to minimize public impact.
- Environmental mitigation measures are part of the infrastructure systems within this Precinct.

### 2.10.11 Precinct J: Open Space

#### a. Vision Overview

The vision for Precinct J is:

The area between the super dike and the Bay of Bengal, which has been reserved for forest, mangroves and a variety of open space (passive/active areas with landscaped/hard/soft as well as canals/creeks/water features etc.) for investors, residents and visitors to BSMSN to enjoy. This area will be a mix of conservation, new mangrove planting and forests to keep the BSMSN resilient and protected from cyclones or natural disasters. In the area closest to the City Centre, a cultural and/or sports facility will be situated with large, public gathering spaces surrounding the buildings to take advantage of the views and vast parkland along the Feni River.

**b. Value Proposition**

The value proposition is:

- Precinct J will be comprised of passive/active open space and conservation/forest areas.

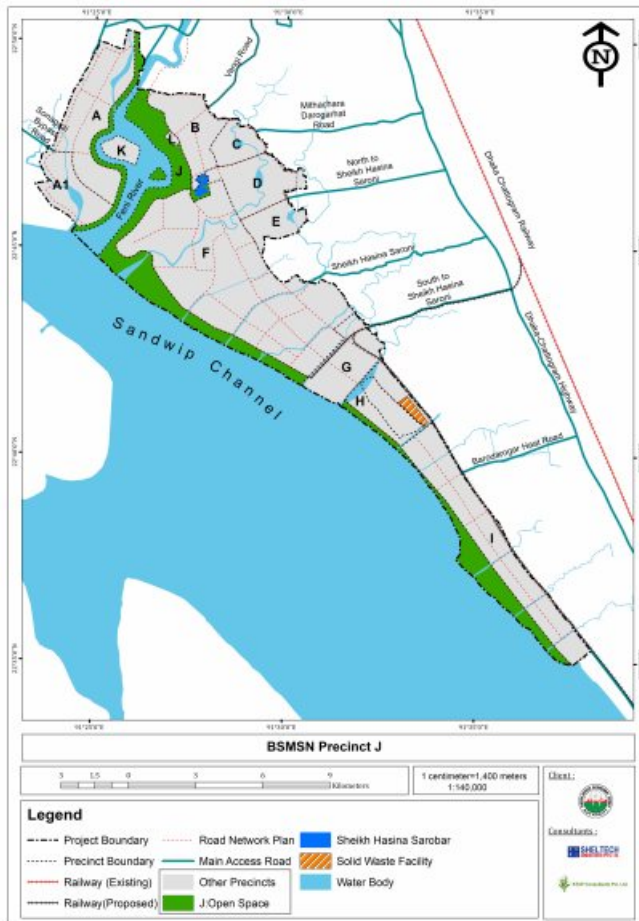

- Precinct J will be designed to minimize effects of climate change and to protect the BSMSN project.
- Precinct J will add value to the BSMSN project by creating a linear park around the site to support a variety of activities.
- Precinct J will contain a cultural and sport facility on the waterfront to be enjoyed and utilized by the public. These facilities will be modern in nature with architectural distinguishing features, which will make the skyline of BSMSN globally recognizable.

**c. Land Use Designation**

The main land use designation for Precinct J is:

- Open Space

Figure 2-15: BSMSN Precinct J

**d. Zoning**

Precinct	Street R.O.W. (Width)	Storeys	Height (m)	Ground Floor Coverage (Percent)	Front Yard Setback (m)	Min. Side Yard Setback (m)	Min. Rear Yard Setback (m)	Landscaped Open Space (Percent)
<b>J Open Space</b>	20m	0	0	0	0	0	0	100%

The permitted uses for Precinct J are:

- Only passive/active/linear park land, forest/mangrove conservation, landscaped (hard/soft) areas or similar are permitted within Precinct J.
- Special public buildings with gathering spaces are permitted under special circumstances but in designated areas only.
- No residential/commercial/industrial/utilities or administrative facilities are permitted in this area.

- Small maintenance buildings are permitted in designated areas.
- Water features, park and street furniture are encouraged.

**e. Special Features**

The special features of Precinct J are:

- Precinct J will be accessible from controlled locations within BSMSN only in order to promote safety and security.
- The Precinct will be monitored by CCTV.
- A variety of park types, which highlight the regions bio-diversity and natural beauty will be prioritized within BSMSN.

**2.10.12 Precinct K: Leisure/Entertainment Area**

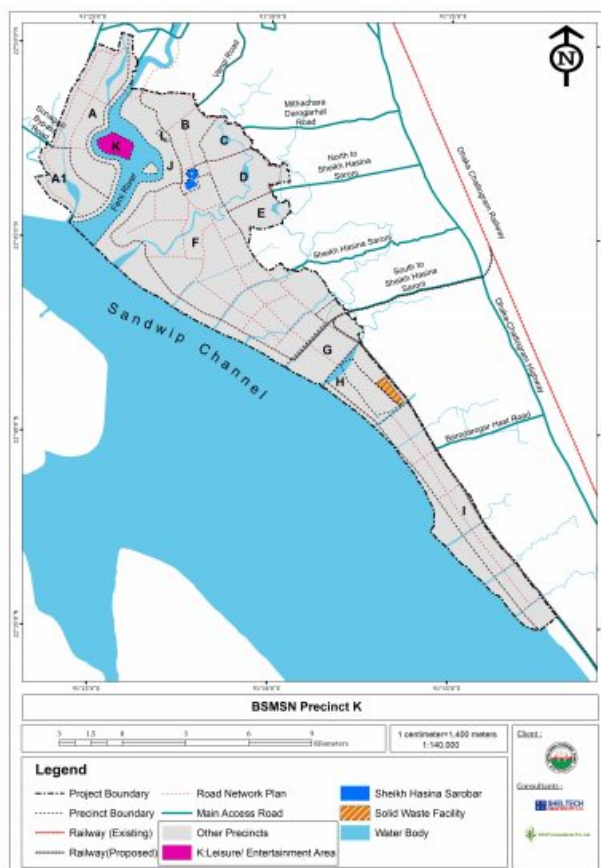

Figure 2-16: BSMSN Precinct K

**a. Vision Overview**

The vision for Precinct K is:

A leisure and entertainment destination in BSMSN. It will be designed to have parks, gathering spaces, marinas, restaurants, cafes, as well as golf and entertainment facilities such as a water park or outdoor cinemas.

**b. Value Proposition**

The value proposition is:

- Precinct K will be accessible from Precinct A.
- A boat shuttle service will be available for day travellers.
- A variety of leisure and entertainment facilities will be located in Precinct K for residents/visitors of all ages.
- Precinct K has spectacular city and sea views.

- Cars/vehicles will not be permitted in Precinct K. The area will have its own transport system consisting of electric cars/carts, buses, and/or trams.
- Precinct K will have a combination of indoor and outdoor facilities/activities.

### c. Land Use Designation

The main land use designation for Precinct K is:

- Leisure/Entertainment

### d. Zoning

Precinct	Street R.O.W. (Width)	Storeys	Height (m)	Ground Floor Coverage (Percent)	Front Yard Setback (m)	Min. Side Yard Setback (m)	Min. Rear Yard Setback (m)	Landscaped Open Space (Percent)
<b>K Leisure/Entertainment Area</b>	20m	3	14	60%	5	3.5	5	30%

The permitted uses for Precinct K are:

- All leisure/entertainment facilities (marinas, restaurants, cafes, sports activities etc) or similar as long as they are not hazardous or dangerous.
- Support amenities such as small-scale retail, restaurants, cafes, marinas, water/sailing sports, golf course, or similar.
- Open space for passive and/or active activities.

### e. Special Features

The special features for Precinct K are:

- Precinct K is an island, which is a unique destination and experience for residents and visitors.
- The island will be accessible from Precinct A.
- A boat shuttle service will be available for day/evening travelers.
- Precinct K will use local varieties of plants and vegetation per guidelines from the Forest Department.
- Safety guidelines/rescue plans for water sports/transport will be developed for the island.

**2.10.13 Precinct L: Cultural Center**

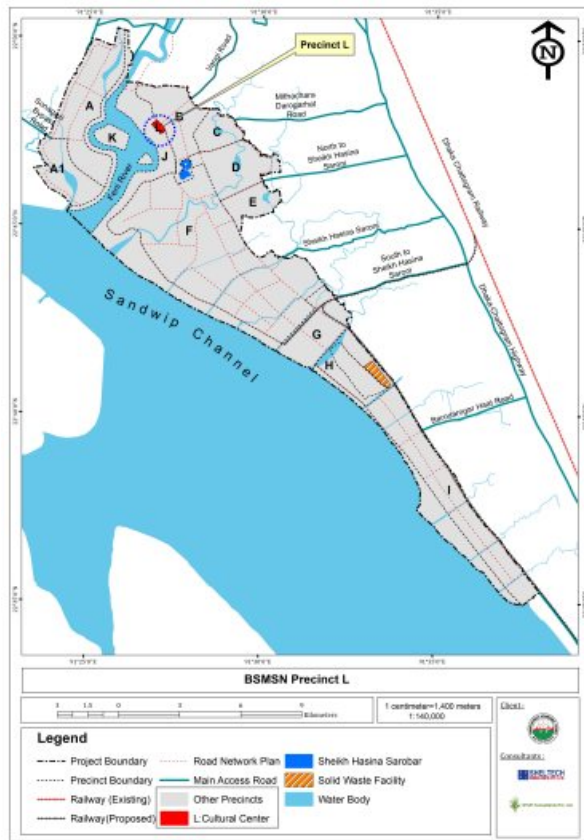

Figure 2-17: BSMSN Precinct L

**a. Vision Overview**

The vision for Precinct L is:

For BSMSN to be the first city/zone in Bangladesh to plan and construct innovative, green performing arts, sporting and cultural buildings along its waterfront (in accordance of the BSMSN Master Plan) to support large-scale gatherings of BSMSN residents, investors, and visitors throughout the year.

**b. Value Proposition**

The value propositions are:

- Precinct L will be accessible from Precinct B. A landscaped pedestrian path/stairs/green space will permit an easy connection from Precinct B to L.

- Sport activities like professional soccer and cricket matches as well as performing arts activities - theatre, film, music, and dance will be available to the general public, year-round.
- Precinct L will also connect to a public open space pathway system that spans the coastline of BSMSN.

**c. Land Use Designation**

The main land use designation for Precinct L is:

- Cultural Facilities

**d. Zoning**

Precinct	Street R.O.W. (Width)	Storeys	Height (m)	Ground Floor Coverage (Percent)	Front Yard Setback (m)	Min. Side Yard Setback (m)	Min. Rear Yard Setback (m)	Landscaped Open Space (Percent)
<b>L Cultural Center</b>	N/A	6	26	70%	N/A	N/A	N/A	30%

The permitted uses for Precinct L are:

- All types of cultural, arts, sports, and festival activities as long as they are not hazardous or dangerous.

- No utility facilities are permitted in Precinct L.

#### e. Special Features

- Precinct L will be well lit for safety, contain an innovative wayfinding system for directional purposes, incorporate green and state-of-the-art technology to make the buildings resilient, cost efficient, and sustainable, and introduce a sophisticated natural landscaped environment to facilitate a variety of events and support public gatherings.
- Public art, local exhibitions, festive banners and statues/sculptures are encouraged in this area.
- Any roads leading to Precinct L must be properly landscaped and well maintained.
- Parking must be well lit to provide safety for visitors. The parking facility must be away from the cultural complex and buffered/landscaped from view. A pathway with pedestrian lighting must be provided from the parking facilities to the cultural complex.
- Views should be protected from Precinct L. This precinct has the best views within BSMSN.
- All utility distribution networks are underground in Precinct L.

#### 2.10.14 Secondary Plans for BSMSN Precincts

At present, BSMSN only has a high-level Master Plan, but Secondary Plans – more detailed local level plans - are needed for each Precinct within the zone. Secondary Plans may be prepared on an incremental basis by the public sector which must be created/adopted before developers/investors bring projects for approval.

The purpose of Secondary Plans is to establish the detailed land use plan, block and street patterns, plot dimensions, open space design, streetscape, transport locations etc., which guides detailed physical growth, as well as, change and improvements in each Precinct. Secondary Plans are based on the vision of the BSMSN Master Plan, and ensure adequate public infrastructure, environmental/resilience protection and social benefits for the Precincts. Secondary Plan policies implement the goals and objectives, land use designations and overall planning approaches set out in the BSMSN Master Plan. Note: All Precincts within BSMSN require detailed Secondary Plans.

Every 5 years the BSMSN master plan may be reviewed and possibly revised. Any new lands acquired/incorporated into BSMSN, adjacent to BSMSN, in the area of influence, or owned/developed/operated by BEZA must be planned, designed and developed in conformity with the BSMSN master plan and under the same vision, rules and regulations as BSMSN.

#### 2.10.15 Monitoring and Assessment of BSMSN

The Master Plan for BSMSN is a high-level document intended to guide development and decision making over the short, medium and long term. As BSMSN develops, the master plan and its guiding policies may require updates or adjustments in response to the changing economics, industrial demand, urban growth, and/or environmental/ social conditions within BSMSN. Monitoring the Master Plan over time in order to respond quickly to potential changes can greatly improve BSMSN and make it more successful. As such, it is vital to monitor and track development within BSMSN over time.

BSMSN will benefit greatly from regularly scheduled assessments of its Master Plan. These periodic assessments will aim to look at: i) the success of the growth management strategies of the Plan, ii) the quality of the living and working environments created, iii) review the sustainability, green and resilience

aspects/success of the project, and iv) examine BSMSN's evolving relationship with the broader urban region. These assessments may reveal new emerging priorities, which should be addressed in updated Secondary Plans, strategic investment strategies, and/or changes to the Master Plan itself. As such, every five years the BSMSN Governing Agency must review the BSMSN Master Plan and associated guiding policies and determine whether there is a need to update portions of the documents.

### 2.11 Phasing of BSMSN

Because all the land within BSMSN has not yet been acquired and some lands have been allocated to investors, it is more complicated to accurately phase the site according to best practices. Considering the above facts, the Master Plan Area has been divided in three phases. The execution period is divided in three phases as follows:

- Phase I : Years 0 - 5
- Phase II : Years 6 -10
- Phase III : Years 11-20

However, to maximize the land values and minimize capital costs within the urban/industrial city/zone, the following phasing rules should be followed in BSMSN:

- Develop land which has been acquired and where investors want to construct.
- Develop core infrastructure and utility networks incrementally within BSMSN/ Precincts so only the required networks/systems are built to support each phase of development.
- Infrastructure/utility networks should never be constructed without demand as they will erode and will need to be replaced, at a later date. This will substantially increase the infrastructure/utility costs within BSMSN.
- It is imperative that all public infrastructure such as access roads and utility networks be constructed within Precincts before investment projects are implemented by investors.
- All public roads and associated utilities (power, water, drainage, sewerage, telecom etc.) should be constructed in an integrated manner with sufficient rights-of-way (ROWS) in order to support maintenance.
- Try to cluster development so one or a few adjacent Precincts are constructed in parallel. Only construct main public roads between existing Precincts and investment projects. Main roads should be expanded only when new Precincts are to be implemented.
- Larger investment projects within a Precinct should be divided into smaller, phased components, where possible. IE. Similar to Zone 2A/B in the Light and Medium Industrial Precinct F. New phases within investor projects should not begin until 70% of the first or previous phase of a project is sold out/leased.
- Resettlement of the identified Feni and Mirsarai communities should be undertaken early on in the development process, as resettlement is the first step in development. The feni resettlement areas should be at the northern edge of Precinct A, closest to the feni community. The Mirasarai resettlement should occur on the northern boundary of Precinct D or E.
- All Precincts are to be planned and implemented as per this Master Plan.



- The BSMSN must have secure fencing around the entire site and be monitored with CCTV.

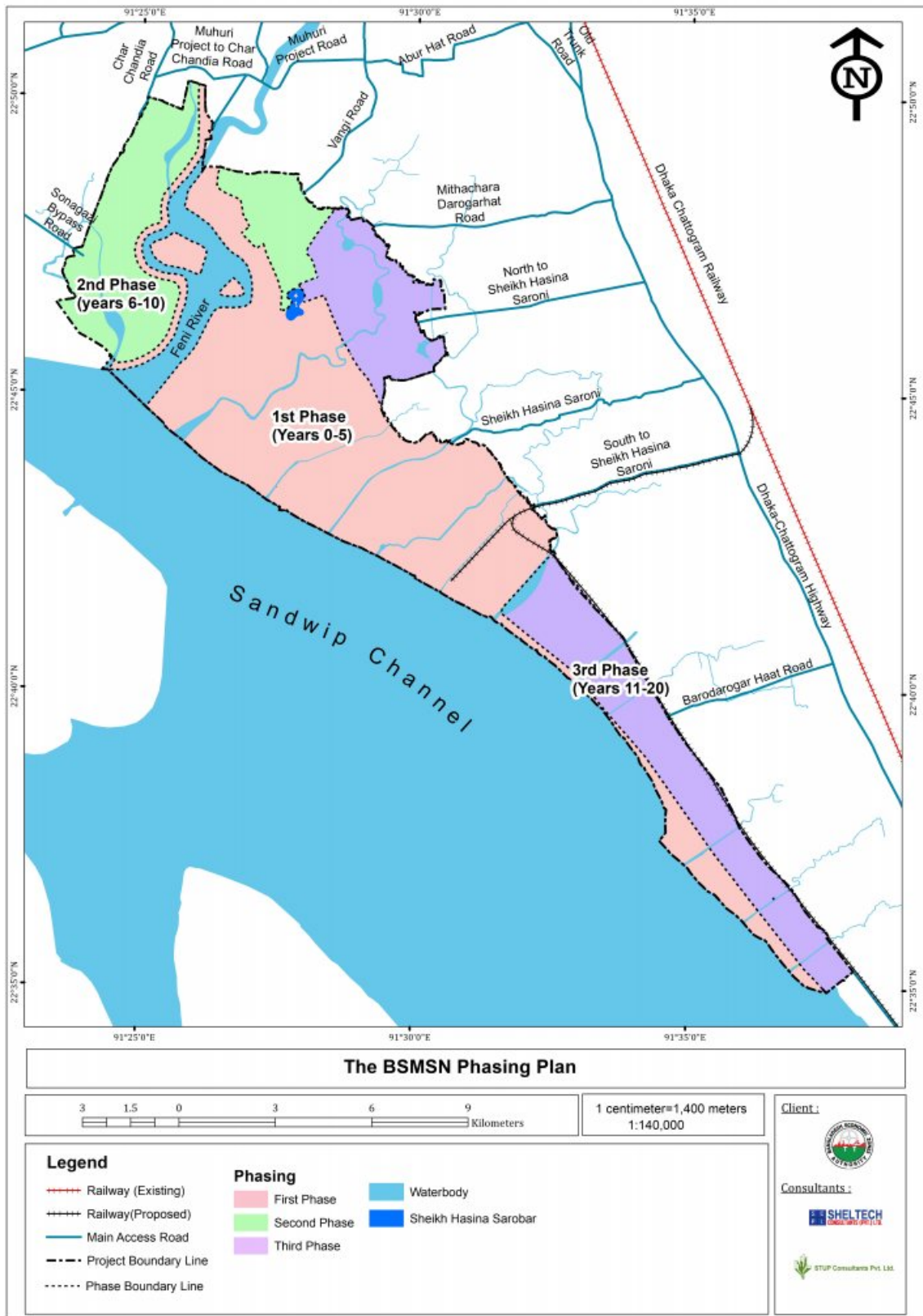

Figure 2-18 The BSMSN Phasing Plan





## ***3. Development Policies and Guidelines***



# 3. *Development Policies and Guidelines*

## 3.1 General Guiding Policies

The following are guiding policies to support the BSMSN's Master Plan. The Guiding Policies, Planning Principles and the Master Plan Maps for BSMSN are to be read together with the Precinct and Green Guidelines, as together they provide a clear design rationale for all development projects envisioned within the zone. (These guiding policies are to be utilized by both the public and private sectors.)

The purpose of these guiding policies for BSMSN is to help create an attractive and safe urban/industrial city, which has:

- Vibrant Precincts with clear land uses to minimize any planning conflicts,
- A variety of housing choices – affordable, medium and high end - which meets the needs of the BSMSN population,
- Attractive, tree-lined streets with various activities, which are at a low-scale, so streets are walkable,
- A comprehensive and high quality, affordable, transit system, which allows people to move around the zone and from Precinct to Precinct, quickly and conveniently,
- A strong and competitive economy with a vital central business district/technology hub, which creates and sustains well-paid, innovative, stable, safe and fulfilling employment opportunities for Bangladeshi's and foreigners alike,
- A healthy natural environment, which promotes clean air, soil, energy and water, green infrastructure/utilities and socio-economic systems, which are resilient to disruptions and climate change,
- A connected system of natural features and ecological functions, which supports biodiversity and contributes to civic life,
- Green spaces of all sizes and shapes as well as public squares, which bring people together and supports public celebrations,
- A wealth of recreational options throughout the zone, which promotes health and wellness,
- A spectacular waterfront, which is healthy, diverse, public and beautiful,
- Cultural facilities, which celebrates the best of BSMSN living and Bangladesh,
- Inspiring architecture and excellent urban design, which astonishes, motivates and excites.

### 3.1.1 *The City Core/Central Business District*

The BSMSN Master Plan has been designed to have a central business district (CBD), which will play a vital role in the zone's growth management strategy. A dynamic central core is critical to the health and economic welfare of an economic zone and the region surrounding it. BSMSN's CBD will be a commercial and financial centre, as well as a business/ICT hub with supporting amenities. The area will be known for its innovative and creative tenants. It is intended that the CBD will host a variety of restaurant/retail/entertainment facilities to ensure the Precinct remains lively after working hours. High rise apartment buildings/condominiums with expansive views will be permitted within the CBD to keep the area safe and secure 24/7. The CBD will have a dramatic skyline with recognizable architectural buildings and features, so BSMSN's landscape can be easily identified around the world. The CBD will be divided into numerous real estate projects for investors.

#### a. **Guiding Policies**

- The CBD will be developed into consistent streets and blocks.
- A variety of real estate projects will be available within the CBD for private or PPP investment.
- All utility distribution networks will be underground.
- New real estate projects will provide at-grade amenities and open spaces to make these development projects within the Precinct attractive, interesting, comfortable and functional. They will have:
  - sustainable street design elements, which may include one or more of the following: trees, shrubs, hedges, plantings or other ground cover, permeable paving materials, street furniture, curb ramps, waste and recycling containers, lighting and bicycle parking facilities,
  - coordinated landscape improvements in setbacks to create attractive transitions from the private to public realms,
  - weather protection such as canopies and awnings,
  - landscaped open space within the development site,
  - landscaped surface parking lots near large scale development and parks,
  - safe, landscaped and lit pedestrian routes, and
  - public art, to make the buildings and its open spaces more attractive and interesting.
- High rise residential projects within the CBD will provide indoor and outdoor amenity space for residents. Each resident will have access to outdoor amenity spaces such as balconies, terraces, courtyards, rooftop gardens and other types of outdoor spaces.
- Street ROWs for this area will be 20m-30m depending if the streets are arterials or secondary roads.
- Transit will be conveniently located and abundantly available throughout the CBD.

- The CBD will promote and support prestige, commercial and landmark office buildings/space, which will help shape the skyline of BSMSN. Areas surrounding these buildings will be landscaped with public squares/gathering spaces, which are filled with pedestrian lighting fixtures and furniture.
- The CBD will be a premier employment area in BSMSN to attract investment.
- Higher height limits and more density is permitted in the CBD to obtain views over the zone and across the Bay of Bengal.
- Support amenities and services along with high rise residential units will be available within the CBD so it remains safe and secure 24/4 – eyes on the street.

### 3.1.2 Tall Buildings

The BSMSN Master Plan only permits tall buildings in the CBD area/ Precinct B. When appropriately located and designed, tall buildings can support and draw attention to the city structure, visually reinforcing BSMSN's financial/technology/civic centre and other areas of civic importance. In the context of BSMSN's relatively flat topography, tall buildings will help define the zone's image. When the quality of architecture and site design is emphasized, tall buildings become important city landmarks. By concentrating development on a small part of the zone (Precinct B), tall buildings will provide high quality, publicly accessible, open spaces and areas for community services and amenities.

#### a. Guiding Policies

Tall buildings come with larger civic responsibilities and obligations. To ensure that tall buildings fit within the planned context of BSMSN's Master Plan, the following must be followed:

- Tall buildings should consist of three parts, carefully integrated into a single whole:
- A base building – which provides definition and support at an appropriate scale for adjacent streets, parks and open spaces. A base must fit into the context of its surroundings and minimize impacts of parking and service uses,
- A middle shaft – the design the floor plate size and shape with appropriate dimensions for the site. The tall building must be located and oriented for the site, in relationship to the base building and adjacent buildings.
- A top – the design the top of tall buildings should be designed to contribute to the skyline character of BSMSN and should integrate roof top mechanical systems into the design of the building, so mechanical areas are not visible.

### 3.1.3 Residential Areas

Diversity of neighbourhoods, in terms of scale, amenities, local culture, retail services and demographic make-up will help define the character of residential communities within BSMSN. The BSMSN Master Plan has four types of residential areas within the zone. In Precinct A, the housing is low density with low height limits. New types of villas, single family residents and bungalows surrounding water features and landscaped areas are the predominant housing typology here. In Precinct B, the housing is tall apartment buildings with numerous amenities and expansive views. In Precinct D, the residential area is a mixed use community. This is low to medium apartment buildings and dormitories with at-grade retail to support the

local population. In the resettlement areas, (which need to be well integrated into BSMSN) must have similar housing and infrastructure/utility networks, as the remainder of the zone.

#### a. Guiding Policies

- Residential neighbourhoods in the BSMSN Master Plan vary depending upon their location and population requirements/needs. The most important aspect of residential neighbourhoods within BSMSN is to ensure they have proper infrastructure/utility networks, are connected to local transport routes, contain support amenities, and remain stable and secure.
- The residential areas within BSMSN will ensure compatibility and compliance with: i) scale and density of the surrounding area and prioritize a transition from adjacent Precincts, ii) adequate light and privacy for residents in Precincts, iii) the screening of services, loading and parking facilities for residential and retail buildings in order to minimize impacts on residents and iv) all utility distribution networks buried underground to improve the streetscape.
- Promote a variety of residential building typologies, which are new to Bangladesh but are used within the South East Asian/South Asia region.
- Integrate resilient water features and landscaping into the design of residential communities.

#### 3.1.4 Administrative/Institutional/Health/Education Areas

The BSMSN Master Plan has been designed to have distinct government, health and educational precincts. The intent is three-fold: i) so BSMSN can be self-sufficient, ii) to bring international level institutional facilities to BSMSN so the schools, universities, health care facilities and government entities can attract foreign and top tier investors, and iii) so institutional facilities can become major contributors to the high quality of life within the zone. In the Master Plan, supporting amenities such as libraries, daycares/nurseries, places of worship, community centers, restaurants, convenience retail etc. have been woven into the Precincts to support the administrative/institutional/health/education areas.

Administrative/Institutional/Health/Education areas are important for many reasons within BSMSN, including: i) they are large employers and attract thousands of employees, patients, students and visitors every day, ii) these major institutions are home to research, cultural and educational institutions that are fundamental to emerging economic sectors, and iii) the clustering and interaction of university, hospital and associated research facilities plays a critical role in innovation and the creation of new products and services for Bangladesh. In BSMSN, major institutions will have the opportunity and the flexibility to partner with the private sector to create joint development projects, research facilities, and/or to house private research and development facilities. Support for these different types of international level institutional facilities have been prioritized within the BSMSN Master Plan

#### a. Guiding Policies

- Institutional Areas within BSMSN will be made up of major educational, health and governmental uses with their ancillary uses, cultural, parks and recreational, religious, supporting small-scale commercial and retail facilities, as well as utility uses. The major health and educational institutions within BSMSN are important employers and service providers and will continue to grow over time, to serve the needs of the growing/developing zone and its surrounding regional population.



- Strong linkages between major international institutions and the private sector to fuel innovation and the creation of new products and services will be encouraged within BSMSN.
- Institutional facilities must only be located within their designated Precinct as outlined in the BSMSN Master Plan.
- All buildings and structures in the vicinity of hospitals and/or heliports must be sited and massed to protect the continued use of flight paths to hospitals and/or heliports. All utility distribution networks must be placed underground.

### **3.1.5 Cultural Areas**

Today, economic zones offer residents, workers and visitors an opportunity to participate in a vibrant sporting and cultural life by recognizing the contribution, which sports and the visual/performing arts makes to improve the quality of life of its population.

Hence, sport activities like professional soccer and cricket matches as well as performing arts activities - theatre, film, music, and dance will enrich the day-to-day experience within the zone and quality of life in BSMSN as a whole. By prioritizing and supporting sporting, performing arts and cultural activities within BSMSN, it will contribute to a healthier zone economy, promote cultural tourism, and help BSMSN to be competitive in attracting and keeping new and foreign businesses, investors and residents.

#### **a. Guiding Policies**

- All sporting, performing arts, and cultural building/complexes will be developed within Precinct L of BSMSN to support local, regional and international events and collectively draw visitors to a specific area around the waterfront, as per the Master Plan.
- The buildings will be architecturally relevant with significant gathering space and public art surrounding the facilities. These areas should be landmarks within BSMSN and must be carefully planned and designed. Attention will be given to keeping the visitors to the sporting and cultural complex safe and secure.
- The sports and cultural complex will be designed using green, energy/water efficient and resilience principles and technology in order to be environmentally-friendly and sensitive to the adjacent park land.
- A full range of sporting events, visual/performing arts and cultural activities from not-for-profit/community/national-based groups to internationally prominent institutions will be promoted and supported in BSMSN.
- The arts and cultural community will be encouraged to participate in the local beautification efforts of BSMSN.

### **3.1.6 Light and Medium Industrial Area**

The BSMSN Master Plan supports healthy industrial investment within the zone. To attract the largest number of foreign investors and Tier 1 players, BSMSN has been separated into two distinct, industrial Precincts – one for light/medium industries (Precinct F) and another for heavy industries (Precinct I). This allows for clean environments within Precinct F and the construction of special infrastructure to minimize

environmental contamination in Precinct I.

However, because the BSMSN Master Plan was delayed, some lands in Precinct F were sold/leased to investors who will undertake heavier industrial projects. As such, the Master Plan has recommended mitigation measures to protect the surrounding light and medium industries and supporting amenities from heavier, industrial activities. In addition, to protect Precinct F from the chemical projects, a small area has been carved out for existing/promised Chemical investors. It will be buffered from the rest of Precinct F to mitigate adjacency issues. (New chemical projects are not be permitted within Precinct F.)

#### a. Guiding Policies

- Only light and medium industries are permitted within Precinct F. Clean environments are prioritized in this area of BSMSN.
- Precinct F will have its own access road into/out of BSMSN from the Dhaka-Chattogram Highway to ensure the separation of truck and motor vehicle traffic. This will increase the safety in this Precinct.
- All industrial lands within BSMSN must have serviced plots. Integrated infrastructure and utility networks are required to be in place before site specific development may occur.
- Roads within investment projects should have 40m, 30, and/or 20m ROWs. Larger roads – 60m ROW should only be to connect investment projects to main arterial roads.
- If heavy industrial activities are within Precinct F, the factories must be set back from the property line with a fence and a landscaped, buffer area around the plot boundary.
- A Chemical Hub within Precinct F has been identified. The size of the Chemical Hub area within the BSMSN Master Plan may not be expanded.
- A 120 acre or more, public park with a lake is required adjacent the Chemical Hub in order to mitigate any negative impacts on Precincts D, E and F. The lake within the Park may be used for solar infrastructure. No buildings, hotels, bungalows or other residential structures are permitted in the park.

### 3.1.7 Port and Logistics Area

The BSMSN Master Plan supports the development of a public port and logistics facilities within the zone. A wide range of logistics facilities should be available within BSMSN. A study is required to determine the scope of the port and logistics requirements in the short, medium and long-term within the BSMSN Master Plan.

#### a. Guiding Policies

- The BSMSN Master Plan supports only one port within the zone.
- If other investment projects within the zone require jetties or piers etc., the location of these elements should be studied, and their placement should be strictly evaluated, so they do not interfere or undermine the location or benefits of the port.
- The port – either a bulk or container port or both– should be available to all tenants within the zone, at a cost.

- Expansion of the port and logistics area may only occur south of the existing port

### 3.1.8 Heavy Industrial Area

In accordance with the BSMSN Master Plan, the area at the south end of the zone (Precinct I) has been identified for heavy industrial sectors and their associated activities. These activities however, should not be hazardous, dangerous or explosive and the environmental contamination from manufacturing and production must be limited, mitigated and monitored. Precinct I is dedicated to heavy industry because the wind patterns on the BSMSN site blow north to south, so the zone will not be affected by any negative impacts from the heavy industry.

#### a. Guiding Policies

- Only heavy industrial sectors and activities are permitted in Precinct I. All activities within this Precinct must not be hazardous, dangerous or explosive.
- All activities must be environmentally mitigated and monitored.
- Precinct I must have its own, dedicated access road to the Dhaka – Chattogram Highway so the heavy trucks and cargo do not interact with motor vehicles.
- There must be roads with 80m and 60m ROWs within this Precinct to support the safe movement of goods.
- The safety of this area must be monitored via CCTV.

### 3.1.9 Parks and Open Space Areas

Parks and open spaces within BSMSN must be designed to offer residents, workers, and visitors to the zone a range of recreational and leisure experiences – everything from the expansive mangrove and plantation areas, meandering, landscaped water canals, to urbane and intimate community parks. These distinctly different green spaces within BSMSN have been proposed so the general population can take a break from the bustle of zone life, participate in local sporting activities, and/or play/relax/enjoy formal and informal, passive and active, hard and soft open spaces. The parks and open spaces within BSMSN contain many of the zone’s natural habitat areas, recreation trails, storm water management facilities and waterfront lands.

#### a. Guiding Policies

- Parks and open space areas are defined by public parks and open spaces, lakes, ponds, watercourses, canals, portions of the waterfront, and the entertainment Precinct within BSMSN.
- Canals and watercourses should be enlarged, lined and landscaped in order to provide improved water catchment ability within BSMSN and/or to act as water features within the various Precincts in the zone.
- Development is generally prohibited within Parks and Open Space Areas except for recreational, sporting, cultural and religious facilities, conservation projects, cemetery facilities, public transit and essential public works and utilities, where supported by appropriate assessments.
- Only compatible recreational, cultural, religious and sporting uses and facilities, which minimize adverse impacts on the natural features and functions are permitted in parks and open spaces within BSMSN,

- Only conservation projects, public transit, public works and utilities for which no other reasonable alternatives are available are permitted in park and open spaces. These must be designed to have only minimal adverse impacts on the natural features and functions, and that restore and enhance existing vegetation and other natural features.
- Protect, enhance and/or restore trees, vegetation and other natural environment features and maintain or improve connectivity between the Precincts, development projects and the natural environment.
- Preserve and/or improve public visibility and access, except where access will damage sensitive natural features or areas, or unreasonably restrict private property rights.
- Where possible, maintain and create linkages between parks and open spaces to create continuous recreational corridors.
- Maintain, expand or improve the size of publicly owned Parks and Open Space Areas for public leisure, recreational and/or cultural purposes.
- Provide comfortable and safe pedestrian conditions within Parks and Open Space Areas for all within BSMSN.
- The sale or disposal of publicly owned lands designated for Parks and Open Space Areas within the BSMSN Master Plan is discouraged.

### **3.1.10 Area of Influence**

It is critically important that the area of influence (10km surrounding BSMSN) is planned in a comprehensive manner and also utilizes these development, environmental and resilient rules and guidelines. This is specifically important for the Char areas adjacent the BSMSN site. These areas must be planned with great sensitivity to the existing environments, land uses and social welfare. The Char regions must be developed appropriately linked to BSMSN to improve BSMSNs value and attractiveness to investors.

#### **b. Guiding Policies**

- The Chars should only be development when Precincts A-F in BSMSN are complete
- A comprehensive plan for the Chars must be developed and the activities proposed should not compete with activities within BSMSN.
- Environmental protection of the Chars should be paramount.
- Any road or sea transport between BSMSN and the Chars should be carefully studied to not impact BSMSN negatively.

### 3.1.11 Multi-Modal Transport Platform

The integration of transportation and land use planning is critical to achieving the overall aim of increasing accessibility throughout the BSMSN Master Plan. The Guiding Policies for BSMSN's Transport Platform are intended to protect the integrity of the Zone's multi-modal transportation network and provide for planned, phased expansion through the designation of public rights-of-way (ROW) and transit corridors.

#### a. Guiding Policies

- Integrate different types of transport systems – road, rail, sea -so each can be used to its full potential and people can move easily throughout BSMSN.
- Integrate the transport networks with the environment so that transport choices support a better environment.
- Integrate transport networks with BSMSN land use planning at national, regional and local level, so that transport and physical planning works together to support more sustainable travel choices.
- Integrate transport with policies for education, health, economic growth, gender and social equity and poverty reduction so that transport helps to make a fairer, more inclusive society.
- Transport and land uses are inter-related issue. Since land use generates transport movements, it is crucial that BSMSNs transport systems are well planned in order to handle the needs that various land uses generate.

### 3.1.12 Utility Corridors

Utility corridors (utility/rail rights-of-ways) play a vital role within BSMSN as corridors for the transmission of energy, communications and the movement of people and goods. These linear corridors are a defining element of the urban/industrial fabric of BSMSN. Rail corridors within BSMSN lead to strategic areas, like the port and industrial areas of the zone. All utility distribution networks are underground in Precincts A, B, C, D, and E. To honor the Master Plan, utilities like power/gas/water stations and/or treatment plants may not be located along main roads or be situated on the highest valued real estate within BSMSN. In addition, the areas around the utilities should be properly landscaped in order to buffer them from the public realm. All utility corridors with distribution networks underground/buried can serve as linear parkland, pedestrian and cycling trails, and transit facilities. Utility corridors should also be secured and protected for the future/expansion of public transit routes or the introduction of mass transit opportunities and used in the short-term as parks or public spaces.

#### a. Guiding Policies

- Utility Corridors are utility and rail rights-of-ways, primarily used for the movement and transmission of energy, communication, people and goods.
- Utility/distribution lines should be placed underground to not clutter the urban/industrial environment. If they need to be above ground, utility plants should be buffered from sight either through fencing or soft landscaping.
- Utility networks should be placed within the road right-of-way and designed for easy maintenance.
- Utilities or their associated treatment or power plants should not be located on prime land or immediately along the street front of main arterials or secondary roads. These locations should be available for private investment.

- Utility networks and corridors should be sustainable, efficient, stable, reliable and resilient within BSMSN and constructed to international standards.
- Power, water, drainage, sewerage, telecom and wastewater/solid waste treatment is required within BSMSN. The networks must be modern, stable, reliable, consistent and utilize green and resilient technology, where possible.
- Utility networks must be implemented in a strategic manner and only in size/quantities to support short-term demand. Utilities should be incrementally increased to optimize the capital costs of the networks.
- Utility plants or above grade networks should be set back from the property line, fenced and landscaped to provide a clear buffer area between the building and the streetscape.

### 3.1.13 Filling Stations

The location of all filling and refueling stations within BSMSN must be planned in a comprehensive manner. All filling station within BSMSN should be along arterial roads (Type A and Type B). In addition, they should not be placed within 100 meters from a road intersection.

#### a. Guiding Policies

- Filling Stations must be located within a 3.0km radius of each other.
- Filling Stations must be developed with service bays.
- Filling Stations should be located at a minimum of 100m from any public institution.
- Where possible, petrol pumps should not be located near residential buildings. If they must be however, the fueling station must be a minimum of 30m from any residential building.
- The minimum plot size for fuel stations should be 35mX35m.
- The maximum building coverage for fuel stations should be 60%.
- Each and every refueling station must be developed with a buffer and proper landscaping. Minimum landscaping within a fueling stations should be 10%.
- The filling station should be bounded by a 2 meter hollow wall.
- All volatile flammable liquid storage tanks must be installed below the ground.
- Stations must be equipped with firefighting and fire protection equipment.
- Adequate containers should be provided for waste.
- Stations should be erected on level grounds.
- Green gas station concept should be promoted.

- Area of land must be developed keeping sufficient space for easy maneuvering of vehicles.

### 3.1.14 *The Public Realm*

Good planning, design, and implementation makes a great economic zone. Great zones have well thought out/quality Public Realms – streets, squares, parks, public spaces and public buildings. Investors flock to ‘specific zones’ around the world, not just to enjoy serviced industrial land, reliable infrastructure/utilities, and financial incentives and benefits, but to live, work and play in a rich and bountiful location, where the natural environment is respected and elevated and international leisure and support amenities are available to create a higher quality of life than norm.

Because of this, the Public Realm will be prioritized and faithfully maintained within BSMSN. Beautiful, comfortable, safe and accessible streetscapes, parks, canals, open spaces and public buildings will become key shared assets in the zone. These public spaces and structures will draw people together within BSMSN and help create strong social bonds at the precinct, zone and regional levels. The Public Realm will also help convey BSMSN’s public image to the world.

#### a. **Guiding Policies**

Quality architecture, landscaping, urban design and international construction standards will be promoted by within BSMSN:

- Identify funding to create and maintain high quality public buildings, streetscapes and public parks, which reflect the broad goals and objectives of this Master Plan.
- Where appropriate, explore the use of international design competitions to seek design excellence and promote international public interest in the design of public projects within BSMSN.
- Prioritize the quality of the Public Realm and ensure all new development projects enhance it.

Design measures, which promote pedestrian safety and security in the Public Realm will be applied to streetscapes, parks, other public and private open spaces in BSMSN. In addition:

- Streets within Precincts A-K will ensure: i) the safe and efficient movement of pedestrians, vulnerable groups such as women, seniors and people with disabilities, cyclists, transit vehicles and users, goods and services vehicles, emergency vehicles, and motorists,
- Streets will incorporate elements, such as utilities and services, trees and landscaping, green/resilient infrastructure, stormwater management, wayfinding, boulevard cafes, and street furniture.
- Public buildings will be located and designed to promote their public status on prominent, visible and accessible sites, including street intersections and sites that end a street view or face an important natural/cultural feature. They will have view corridors, sky views and access to sunlight.
- Open space associated with public buildings will be designed to enhance the quality setting for the building and support a variety of public functions associated with its program.
- Provide sidewalks and boulevards within BSMSN, which will be designed to provide safe, attractive, interesting and comfortable spaces for pedestrians. This will include street trees,

landscaping, pedestrian-scale lighting, quality street furnishings and decorative paving as part of street design.

### **3.1.15 Public Art**

Traditionally public art, both publicly and/or privately owned, makes the experience of traveling through a zone's streets, open spaces and parks more pleasurable for residents, workers and visitors alike. Hence, because public art has a broad international and local appeal and many documented social benefits, it should be incorporated into BSMSN so public art can help contribute to the identity and character of the zone - create a number of landmarks, special places, as well as start a conversation with residents within the zone. To achieve this goal, a partnership between the public and private sectors should be established, in order to support public art within BSMSN.

#### **a. Guiding Policies**

The creation of public art, which reflects Bangladesh culture, heritage and creativity will be promoted within BSMSN by:

- Developing and adopting a Public Art Master Plan to coincide with the Master Plan Precincts,
- Encourage public and private funding for public art installations, without conflict of interests,
- Actively promote art installations by local artists,
- Promote public art in front of government and private sector buildings and structures, where appropriate,
- Encourage the inclusion of public art in all significant private sector developments across BSMSN.

### **3.1.16 Applicability of Bangladesh National Building Code (BNBC)**

Although the BNBC shall be applicable and adhered to for the construction of BSMSN, the zone will use international building standards throughout the site, which are more onerous than Bangladesh's building code.

## **3.2 General Environmental Guidelines**

All development within BSMSN must have all of its environmental clearances before any development is permitted. In addition, the following environmental considerations must be met along with all other mandatory environmental and green resilient guidelines, rules and regulations:

- Within BSMSN, a minimum of 10% of the total land area must be reserved for open space.
- All roads within BSMSN must have sidewalks, as well as pedestrian and street lighting and must be lined with a single or double row of trees depending upon the location of the road and how wide the road is. All trees shall be planted no more than 4 meters apart.
- Heavy vehicles and cargo transportation shall not be permitted in Precincts A, B, C, D, E and L.
- BSMSN must be designed to be eco-friendly, environmentally responsible, and resilient.



- Solar, renewable energy, recycling, and green technology must be incorporated into the design of the BSMSN project.
- Within BSMSN, an uninterrupted supply of potable water (maintaining drinking water quality, as per DOE, GOB or WHO) is mandatory as well as grey water. Water plants, transmission and distribution networks and wastewater treatment plants must be constructed in accordance to international standards.
- All sewage within BSMSN must be properly-managed/treated. Hence a Sewage Treatment Plant (STP), (per DOE, GOB, and STP guidelines) must be constructed within the zone in accordance with international standards.
- Land within or outside BSMSN must be reserved for a Municipal Solid Waste Management Treatment Plant/Disposal / Sanitary Landfill site for the project.
- BSMSN is a plastic-free zone. The use of polythene bag / plastic bag shall be prohibited within BSMSN.
- Solar lighting is mandatory within BSMSN. Hence, street lighting / boundary lighting etc. must be solar powered.
- To promote energy conservation, the use of energy efficient lights / high efficiency light systems (IE. T5 Tri phosphor Fluorescent, LED etc.) is mandatory within BSMSN.
- Fire services/emergency services for fire-fighting and medical facilities must be present in each Precinct.
- All power sub-stations must be properly fenced and buffered with landscaping to reduce impacts on the road and improve security of the infrastructure.
- As much as possible, green and resilient technology must be used for all large buildings/plots within BSMSN.
- All water channels within BSMSN must be designed to capture and drain water from the surrounding areas outside BSMSN into the Bay of Bengal. These channels shall be kept active and shall be lined, planted and enlarged to become water features/lakes/streams, and water reservoirs/harvesting/collection within BSMSN.
- A rainwater harvesting system designed to capture roof run off from a minimum of 200m<sup>2</sup> (or 50% of the available roof catchment area for roof areas less than 400m<sup>2</sup>) during regular rainfall events must be incorporated into each building. The collected rainwater shall be plumbed to supply a seasonally independent water use. IE. Toilet flushing and landscaping etc.
- Most of the components in BSMSN require environment clearance from DOE, GOB (Orange –B category) as per The Environment Conservation Rules, 1997 and its amendments.
- No construction / developmental activities within BSMSN shall be permitted until environment clearance is granted/received from DOE.

### 3.3 Resilience Infrastructure Planning and Design for BSMSN

#### 3.3.1 BSMSN Fueled By Next Generation Infrastructure

From serving man's basic needs to enabling business activities and innovation, infrastructure supports the well-being of people and the development of economies. Reliable transport, energy, water, sanitation, and telecommunication services are essential for raising the quality of life of people. Additionally, access to basic infrastructure services is a central factor in the productivity of firms and economic zones, making it a key enabler of developing competitive industries. And in this time of rapid climate change and intensifying natural disasters, infrastructure networks are under pressure to deliver resilient and reliable services<sup>5</sup>,

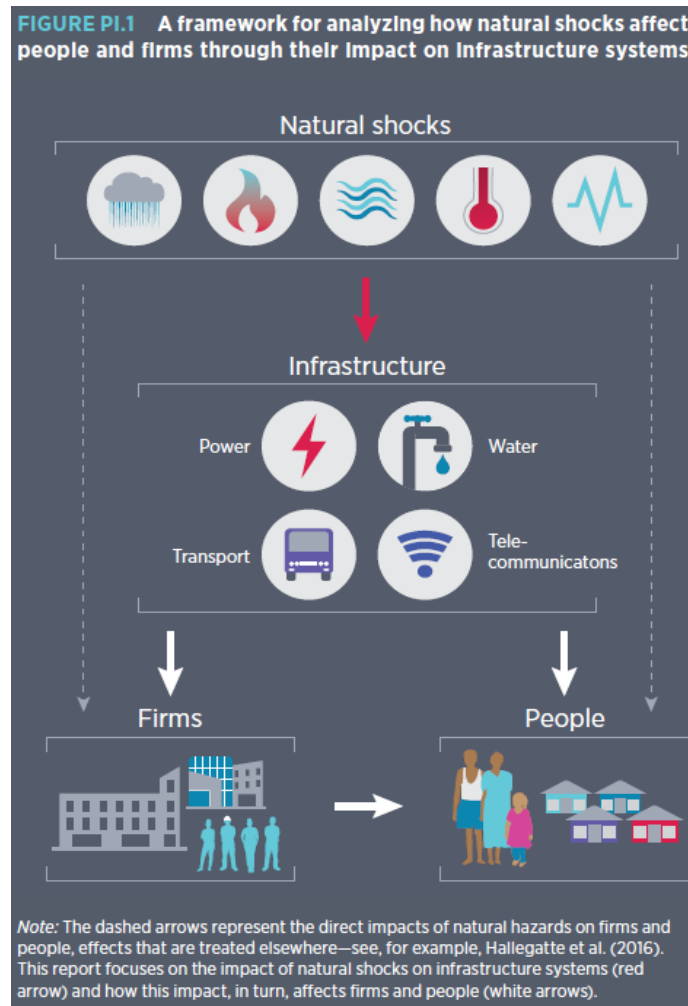

Figure 3-1: A Framework for Analyzing How Natural Shocks Affect People and Firms

which is a key concern for coastal developments such as the BSMSN site. **Investing in resilient infrastructure is sound, profitable, and urgent.** Global studies<sup>6</sup> have shown that disruption to infrastructure costs households and firms in low- and middle-income countries is at least \$390 billion a year, and the indirect effects place a further toll on households, businesses, and communities. The same

<sup>5</sup> From Hallegatte, Stephane; Rentschler, Jun; Rozenberg, Julie. 2019. *Lifelines : The Resilient Infrastructure Opportunity*. Sustainable Infrastructure;. Washington, DC: World Bank. © World Bank. License: CC BY 3.0 IGO. For more information see: <https://openknowledge.worldbank.org/handle/10986/31805>

<sup>6</sup> From Hallegatte, Stephane; Rentschler, Jun; Rozenberg, Julie. 2019. *Lifelines : The Resilient Infrastructure Opportunity*. Sustainable Infrastructure;. Washington, DC: World Bank. © World Bank. License: CC BY 3.0 IGO. For more information see: <https://openknowledge.worldbank.org/handle/10986/31805>

study also finds that the extra cost of building resilience into these systems is only 3 percent of the overall investment needs. Because of fewer disruptions and reduced economic impacts in developing countries, the overall net benefit of investing in resilience infrastructure turns out to be \$4.2 trillion over the lifetime of new infrastructure. This is a \$4 benefit for each dollar invested in resilience. **Figure 3-1** illustrates a framework for analyzing how natural shocks affect people and firms through impacts on infrastructure systems.)

Developing resilient infrastructure is about adjusting the way we plan, design, construct, monitor and manage infrastructure assets and systems, by considering climate and disaster risks, as well as creating a system to quickly and effectively respond to disaster events, so that when disasters strike, disruptions of infrastructure services and the lives, which rely upon them can be avoided or minimized. It's about building and managing bridges, which can withstand more frequent or stronger floods, water pipes, which can resist earthquakes, or electric poles, which are sturdier in the face of more intense hurricanes. And it is also about making sure people will not lose their jobs because they cannot get to work, that they can get urgent medical care, and that their children can get to school<sup>7</sup>.

Resilient infrastructure is often green infrastructure, and vice versa. Infrastructure services, which are resilient to climate and disaster risks are often environmentally sustainable. Similarly, infrastructure, which is resource efficient and low emitters of greenhouse gases and pollutants can also withstand or recover quickly from disaster events. For example, a resilient water supply system would require a combination of traditional and nature-based solutions, including freshwater intake, wastewater recycling, (solar-powered) desalination, rainwater harvesting and utilization, etc. With good management and coordination, these infrastructure systems, which rely on a variety of sources enable redundancies which could disperse or minimize risks, as well as mitigate climate and environmental footprints. Furthermore, investing in green and resilient infrastructure could reduce waste, improve resource and energy efficiency within economic zones and industrial production, and in turn, cut operations and maintenance costs. (Often these costs for green and resilient infrastructure can be paid off before a disaster strikes.<sup>8</sup>) This creates opportunities to deliver these economically viable green and resilient infrastructure services through attracting private investment, expertise and financing including through public private partnership (PPP) models.

For these reasons, enhancing the resilience of the foundational/core infrastructure within BSMSN is critically important to developing a sustainable and competitive industrial city. Bangladesh is one of the most vulnerable countries in the world to cyclones and floods, particularly in the country's coastal areas where BSMSN is located. Cyclones and associated storm surges and floods have led to nearly 520,000

<sup>7</sup> From Hallegatte, Stephane; Rentschler, Jun; Rozenberg, Julie. 2019. *Lifelines: The Resilient Infrastructure Opportunity*. Sustainable Infrastructure;. Washington, DC: World Bank. © World Bank. License: CC BY 3.0 IGO. For more information see: <https://openknowledge.worldbank.org/handle/10986/31805>

<sup>8</sup> There is increasing evidence that also demonstrates that investment in resilient infrastructure and services pays off, even before a disaster strikes. Integrating multi-purpose designs into green and resilient infrastructure investments can save money and attract private investment\*(examples include: i) a micro-grid system that provides back up power supply to tenant firms and local evacuation shelters during disasters, and at the same time, increases energy efficiency and reduces GHG emissions during normal operation or 2) a retention pond protected with improved coastal and river embankment designs, which also provides serviced low-risk industrial area for placing floating solar). It serves broad beneficiaries including tenant firms, workers and local communities, and can justify high capital costs by increasing usability, amenity and value of industrial land, revenues from land sales/ lease, energy efficiency, utility cost savings, private investment, and GHG emissions reductions.

\*Tanner, Thomas; Reid, Robert Curle Jesse; Wilkinson, Emily; Rajput, Sumati; Surminski, Swenja; Maruyama Rentschler, Jun Erik. 2018. The triple dividend of resilience: realizing development goals through the multiple benefits of disaster risk management. Washington, D.C.: World Bank Group. <http://documents.worldbank.org/curated/en/993161515193991394/The-triple-dividend-of-resilience-realizing-development-goals-through-the-multiple-benefits-of-disaster-risk-management>

natural disaster deaths recorded over the past 40 years. These events also have the potential to cause significant economic damage. Cyclone Sidr in 2007 cost an estimated \$1.7 billion in damages and losses. The country's extreme vulnerability to hydro-meteorological hazards, including storm-induced tidal flooding, is likely to increase due to climate change. (Zones inability to be prepared for the impacts of extreme weather events.) This increasing vulnerability to climate change may significantly reduce Bangladesh's industrial competitiveness, which heavily relies on labour-intensive and export-oriented manufacturing. Without adequate measures, the operations of economic zones and zone tenants could be disrupted for a prolonged period of time with repeated damages. Such disruptions can increase perceived business risks amongst global buyers, which may in turn, negatively affect Bangladesh's competitiveness in global markets.

Analysis shows that the location of the BSMSN site potentially faces significant climate and disaster risks – namely floods, earthquakes and subsidence. At the same time, there are a number of opportunities and options to have cost-effective, structural and non-structural solutions for key infrastructure assets and services within BSMSN against climate and disaster risks. A desktop technical analysis<sup>9</sup> of BSMSN was undertaken to review the key climate and disaster risks, their impacts on proposed critical infrastructures, and to highlight potential solutions and options to enhance their resilience, drawing upon good practices and lessons learned in Bangladesh and internationally. The following sections summarize the key findings from the analysis on the risks and resilient infrastructure options applicable to BSMSN.

### 3.3.2 Climate Change and Natural Hazard Risks Facing BSMSN

The BSMSN site is situated in an area subject to significant risks of climate change and natural hazards, particularly floods and earthquakes. BSMSN is located at the mouth of the Feni River and has a 25 km border with the Bay of Bengal. The +/- 30,000-acre site is strategically located 200 km from Dhaka and 60 km from Chattogram, home to the country's largest port and one of the busiest ports in South Asia. BSMSN will be developed on previously uninhabited, reclaimed land protected by a recently constructed coastal, super dyke and river embankments. Given the site's location, geological conditions, and climate change position, BSMSN is susceptible to a number of disaster risks, including but not limited to: i) coastal, pluvial and fluvial floods and strong winds caused by heavy rains, ii) cyclones, and storm surges, etc., iii) earthquakes, iv) land subsidence, and v) heat waves and water shortages caused by long periods of high temperatures and a lack of rain.

#### a. Floods

Flooding is considered the most critical natural hazard for the BSMSN site, given its proximity to bodies of water and its elevation, which is at or below sea level. Sea-level changes/increases due to climate change is expected to produce flood damage on the site without mitigation. As shown in **Figure 3-2**, the coastal area proposed for development in BSMSN is subject to a variety of types of flood hazards including: i) coastal floods caused by high tides and storm surges, ii) fluvial or river floods caused by river overflow, and iii) pluvial or urban floods caused by poor drainage of heavy rain on the site. Although different causes trigger these hazards, their consequences (such as inundation) as related to infrastructure assets and services, are similar.

<sup>9</sup> The World Bank Group in partnership with Bangladesh Economic Zone Authority commissioned a study, "Enhancing Competitive, Green and Resilient Industries in Bangladesh: Integrating resilience within the design and costing of BSMSN Economic Zones 2A and 2B," (Miyamoto International, 2020).

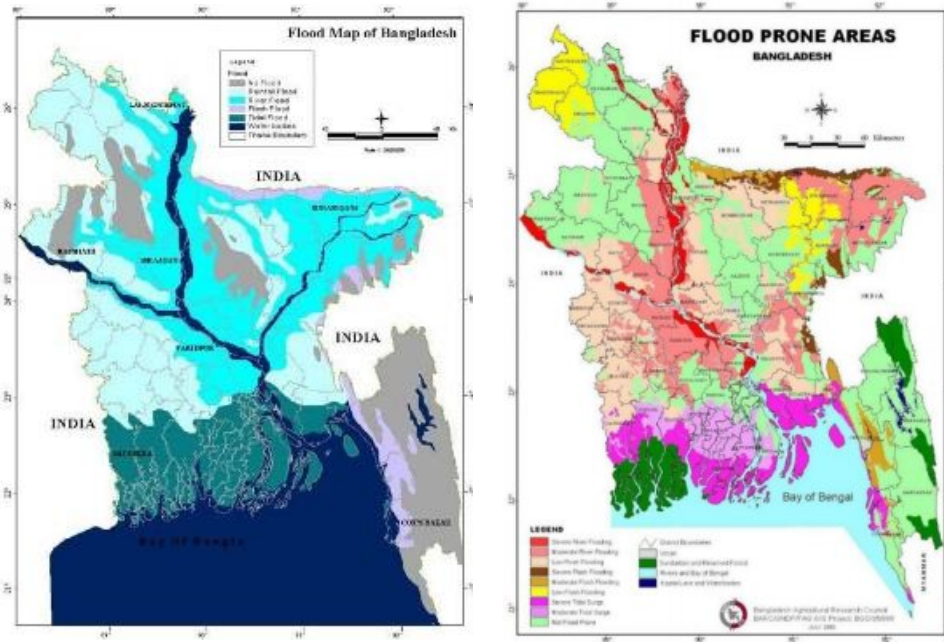

(WARPO, 2009)

(BARC, 2000)

Figure 3-2 Flood Hazards for the Target Area

BSMSN’s first development initiative was to raise its land and build a super dyke in order to protect the site against various flood risks. The super dykes are designed and constructed with crest elevations at MSL10+9.0 m to protect the site against a 100-year return period coastal flood<sup>11</sup>. River embankments are designed and constructed with crest elevations at MSL+8.0 m to protect the site against river overflow from a 25-year return period river flood<sup>12</sup>. The land plots are being raised from initial ground levels from an average of MSL +4m to MSL +6.5 m, in order to protect all development/investment from inundation from historical maximum water levels at the coast line and rivers<sup>13</sup>.

**b. Earthquakes**

**BSMSN is located in a highly seismic region, which can experience significant ground shaking and disruption.** In Bangladesh, the building code divides the country into four seismic zones, as shown in The project area is located on the border of Seismic Zones 2 and 3. Zone 3 is considered a severe seismic zone, with a seismic coefficient of 0.28 (Figure 3-3).

10 Equivalent to PWD/PWDB which is the datum used by the Bangladesh government set by the Public Works Department (Yachiyo Engineering Co. Ltd., 2020)

11 Source of Information: Technical Discussion with China-Harbor and China Civil Engineering Construction Corporation

12 Source of Information: Technical Discussion with China-Harbor and China Civil Engineering Construction Corporation

13 Source of information: Based on the calculation files provided by the consultant through World Bank

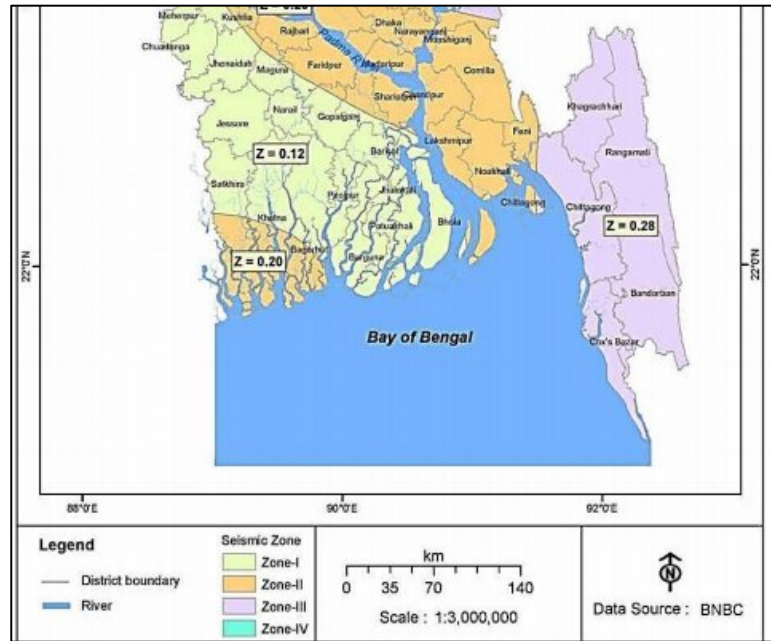

(Source: BNBC, 2015)

Figure 3-3: Seismic Map of Bangladesh

### c. Land Subsidence

BSMSN is also susceptible to land subsidence due to its geological foundation. As seen in the geological map in **Figure 3-4**, BSMSN is categorized as coastal deposits, beach, and dune sand. This type of underlying soil has an adverse impact on infrastructure because: i) it is susceptible to liquefaction, ii) it can undergo settlement and particularly, differential settlement<sup>14</sup>, and iii) it will amplify seismic waves. As shown in **Figure 3-5**, the site's region has low Standard Penetration Test (SPT) counts or has a soft soil thickness of 5m to 10 m. Hence, the project's initial investment phase included the construction of dykes, site infill of close to 4 m, and regional water catchment areas with a system of canals to prepare the low-lying lands for development.

<sup>14</sup> For infrastructure, settlement denotes the subsidence of soil under the foundation. For sites where there is different underlying soil, or when there is a significant difference in applied loading at various parts of the infrastructure, differential settlement can occur. As a result, the subsidence is more pronounced for some parts of the structure compared to adjacent sections. This, in turn, imposes high demand on structural member spacing between the two

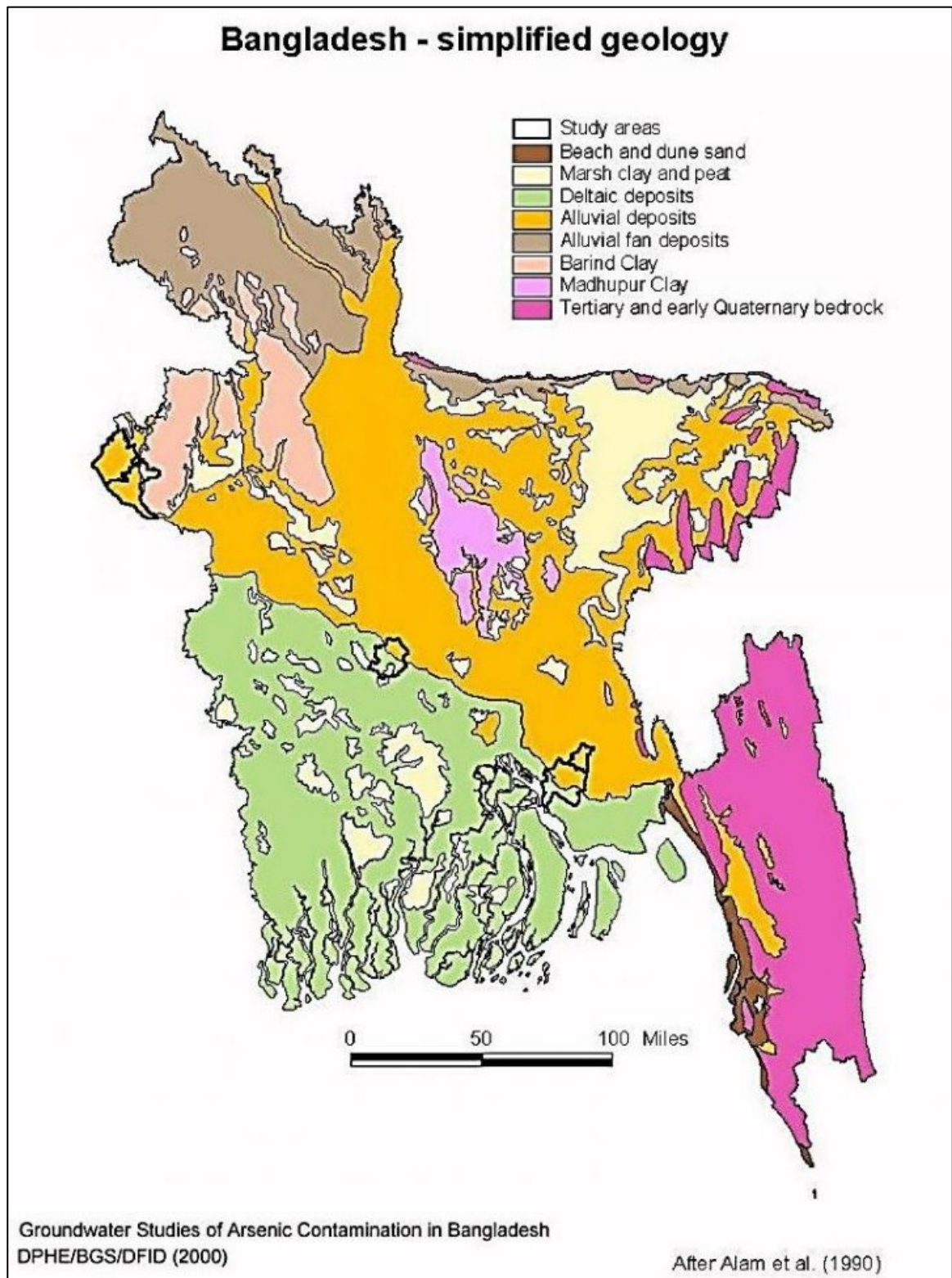

(Source: BWDB, 2013)

Figure 3-4: Geological Map

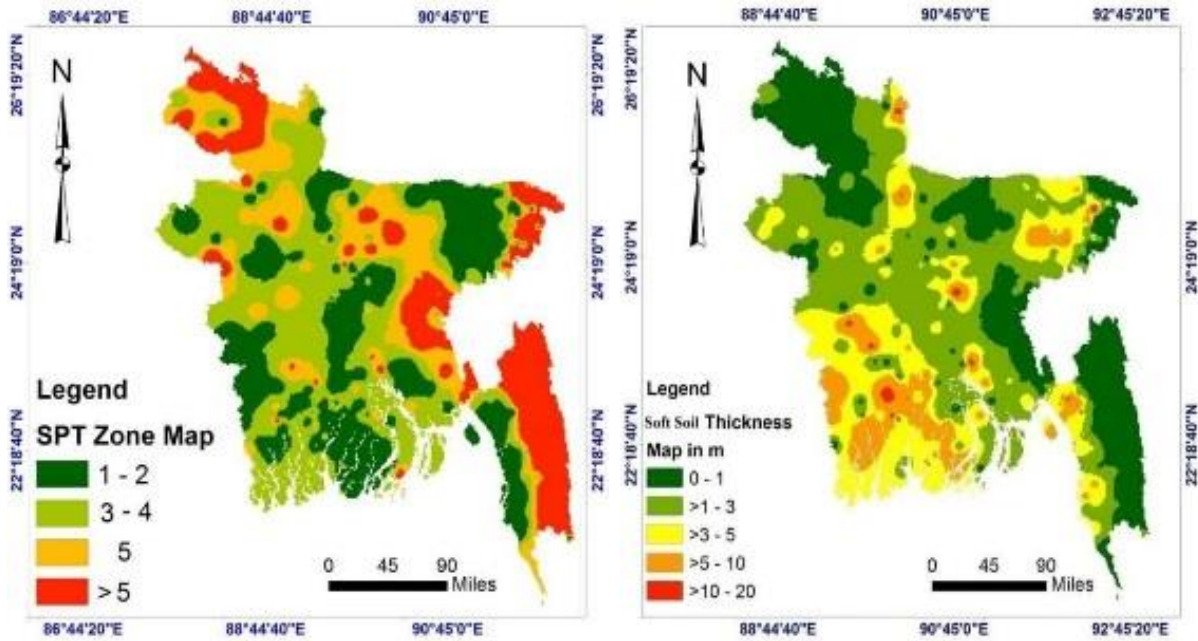

(Source: Hore et al., 2019)

Figure 3-5:. Site Characteristics

### 3.3.3 Key BSMSN Infrastructure

Various types of infrastructure/utilities will be developed to international standards within BSMSN to provide world-class networks, structures and services, which will make BSMSN a competitive, sustainable, and resilient zone. These infrastructures/utilities differ in their structural characteristics, services and functions, and performance standards. However, the key approach to enhancing their resilience<sup>15</sup> is equally dependent upon their structural and operational robustness to minimize damages, losses, and service disruptions in face of the significant risks climate change and natural hazards faced at the BSMSN site.

Table 3-1 below, provides an overview of the types of general infrastructure envisioned for BSMSN. The infrastructure has been organized by the types of key functions and services they provide:

Table 3-1: Key Types of Infrastructure Services and Assets Planned for BSMSN

Key Infrastructure, Services and Functions	Types of Infrastructure/Utility Assets
Flood Protection and Management	Coastal Embankments, River Dykes, Pumps, Gates, Storm Water Drainage, etc.
Transport	Roads, Bridges, Ports, Rail, Light Rapid Transit etc.
Buildings	Factory Shells, Administration Building, Residential/Commercial/Retail/Educational/Medical Buildings, Fire Services, etc.
Telecommunication	Towers, Cables, Fiber Optics, Backbone, Switches, etc.
Water Supply and Sanitation	Water System (Potable/Grey), Sewage Treatment Plants (STP), Water Treatment Plants (WTP), Water Reservoirs, Desalination Plants, etc.
Energy	Power Plants, Sub-Station, Solar Panels (including Floating Solar) Renewable, etc.
Waste Management	Waste Treatment Plants (CETP), Bio-Gas Plants etc.

(Source: Modified from PwC, 2016)

<sup>15</sup> defined as infrastructure’s abilities to: 1) avoid or minimize loss and damage; 2) continue or resume operations quickly; and 3) maintain and enhance competitiveness of the city and economic zones as a result of minimal disruption of infrastructure assets and services.



### 3.3.4 Approaches to Enhance Resilience Through the Master Plan

The key approach to enhancing infrastructure resilience within BSMSN is to consider disaster and climate change risks within the initial process of planning, design, construction, maintenance, and monitoring of infrastructure/utilities, as well as putting in place capacities and mechanisms to respond quickly to disaster events. Therefore, the Master Plan, where planning decisions are first defined for BSMSN, is where infrastructure/utility resilience is initially introduced and outlined.

Hence, the key principles of resilient infrastructure/utilities for BSMSN are:

- **Infrastructure<sup>16</sup> planning and siting.** Where possible, critical infrastructure is developed in locations with lower climate and disaster risks. In case of floods, this means locating critical infrastructure assets, equipment and facilities on higher elevations or away from water bodies. For earthquakes and liquefaction, the overall disaster risks (based on available risk assessment information) are uniform throughout the site. As such, there are no special areas, which require unique resilience considerations within BSMSN.
- **Structural design and construction.** Due to the location and geological condition of the BSMSN site, as well as to provide the required infrastructure services, siting critical infrastructure completely away from climate and disaster risks may be difficult. Therefore, as part of the infrastructure design phase of the project or any of its components, it is important that site-specific infrastructure risk assessments be undertaken for flooding, earthquakes, and subsidence. (IE. Flood risk modelling, geotechnical analysis, etc.) For core infrastructure within BSMSN, this assessment should be undertaken either at the feasibility stage or during the structural design process. For floods and earthquakes, general structural measures to enhance resilience are to: i) ensure compliance of design and construction with national and international standards and good practices, ii) assess critical aspects of infrastructure assets and services and take advanced measures for core infrastructure assets and services (IE. applying higher standards for seismic and flood resilience for higher value buildings or equipment, etc.), and iii) ensure proper quality controls on construction methods, techniques and supervision.
- **Maintenance and monitoring.** A lifecycle management approach is essential for infrastructure resilience, as it enables infrastructure assets to sustain higher levels of performance throughout their lifecycle, including in times of disaster events. For all types of climate and disaster risks, including floods and earthquakes, resilience can be improved through developing enhanced maintenance plans, as well as, real-time infrastructure asset monitoring, management, and warning systems. These management plans should also include financing plans and options for regular monitoring and maintenance work, as well as repair and replacement work, which will be required throughout the design life of the infrastructure to ensure and sustain its peak performance.
- **Emergency response and business continuity planning.** In addition to the planning/investing in measures to strengthen infrastructure against disasters and climate change, putting in place a plan and system to respond to emergency situations and continue and/or resume operations is a critical infrastructure resilience measure. Therefore, the development of: i) flood hazard maps, ii) emergency evacuation plans, and iii) business continuity and management mechanisms to minimize infrastructure disruption in face of various types of climate and disaster events is important. These plans should include or be informed by an analysis of financing options and mechanisms to cover the repairs, recovery, and reconstruction work required to ensure continuity and minimize disruption of infrastructure assets and services.

<sup>16</sup> Infrastructure refers to all roads and utility networks required for BSMSN.

- **Resilience measures may add to the initial cost of development in BSMSN, however, it can significantly reduce long-term life cycle costs and save lives.** The initial cost of resilient infrastructure is not the proper index to assess the suitability of design alternatives for infrastructure due to the long service life and recurring service costs. Thus, resilience measures are to be assessed with a life cycle cost assessment (LCCA). LCCA's for conventional and resilient design will usually show the lowest overall costs to the funding/implementing agency for the increased resiliency. The comparison becomes even more favourable when users and third-party costs are included in the analysis. Based on finite resources, initial and life cycle costs can be used to prioritize both infrastructure classes and candidate enhancement alternatives for each type of infrastructure.

### 3.3.5 Resilience Options for BSMSN's Infrastructure

Based on overall resilience considerations and principles highlighted above, specific infrastructure measures have been developed for BSMSN. The following infrastructure resilience options must be integrated into the design and implementation of all infrastructure within BSMSN.

#### a. Infrastructure for Flood and Earthquake Protection and Management

Given that BSMSN is a new, large, coastal development located on previously uninhabited reclaimed lands facing the Bay of Bengal, flood and earthquake protection and management are three of the most critical core infrastructure requirements needed to support the BSMSN's development, operations, sustainability and viability. Therefore, understanding and enhancing the ability to protect and manage floods and earthquakes, as well as, implement measures, which can minimize the potential loss and damages in the face of growing climate and disaster risks are critical resilience options to consider within BSMSN.

- **Risk considerations.** Flood and earthquake protection infrastructure and its management must be designed so that the BSMSN site is protected against earthquakes and floods. For floods, to the level of a 1 in 100-year coastal flood, a 1 in 25-year river flood, and to historical maximums of pluvial floods. Given its function for protection, resilient infrastructure must be developed in high flood-prone areas along the sea and rivers in BSMSN, which may be vulnerable to extreme weather events and measures must be taken throughout the site to minimize impacts of earthquakes.
- **Resilience measures.** Various detailed measures to enhance resilience against flooding and earthquakes within BSMSN, as well as, further enhance performance are illustrated in Appendix Tables B1 and B2.

#### b. Coastal Embankments and River Dyke Guidelines

Key resilience measures for BSMSN include:

- **Capacity design.** Apply a higher design level for floods in BSMSN. IE. River dykes must be engineered to a 25-year return period based on historical observations. This could be enhanced, in order to take in to account unexpected high tides, river flooding and /or increasing sea levels due to global warming.
- **Redundancy design.** Prepare for unexpected failures. Impose high redundancy to mitigate unexpected or extreme high tides, river flooding, as well as seismic events.
- **Structural design.** Monitor the actual settlement anticipated by the installation of PVDs to ensure that design capacity has been met. Resilience could be enhanced, particularly for unexpected high tides and river flooding.

- **Real time monitoring systems.** Develop real-time monitoring systems for water levels and the collection of geo-technical data. This could reduce the impact of heavy floods and earthquakes on zone inhabitants and facilities and improve/promote site-specific and more accurate water levels and soil stability /liquefaction estimates.
- **Enhanced maintenance.** Monitor the movement of concrete blocks on the oceanside of the coastal embankment area and install bigger blocks and/or add more concrete blocks, if the integrity of the dyke is compromised.

#### c. Pumps and Gates Guidelines

Key resilience measures for BSMSN include:

- **Installation of flap valves/gates or pump stations.** In order to prevent water backflow from the outfall and to make the drainage systems within BSMSN more flood resilient, installing flap valves/gates at the outfall or constructing a pumping station may be an option to be considered.
- **Utilization of mobile pumps.** For BSMSN, a mobile pump or a pump vehicle is proposed for instances when rainfall intensity exceeds the capacity of the drainage network. Emergency pumping equipment is a useful counter-measure against local, water inundations due to heavy rainfall (IE. Inundation of water around the base of buildings).
- **Measures against high water levels.** Provide gates and water retention ponds, when needed at drainage outfalls to control water discharge into channels and to prevent water backflow/ subsequent inland flooding due to high water levels of the channels caused by heavy rainfall, strong storms or high tides.

#### d. Stormwater Drainage Guidelines

Key stormwater drainage resilience measures for BSMSN include:

- **Earthquake resilient drain joints.** Earthquake resilient drain joints (flexible and/or expandable joints) are recommended for underground drain pipes or box-culverts in order to resist large ground movement caused by earthquakes.
- **Real-time monitoring systems.** Develop real-time monitoring systems for rainfall to enhance location-specific information and analysis of rainfall, return period, etc.
- **Rainwater harvesting, storage, and utilization.** Rainwater harvesting, storage, and utilization through the installation of water retention ponds, tanks, and permeable surfaces in parks, open spaces, parking lots and road networks etc. can temporarily hold, store and reduce the concentration of stormwater, which could overflow drainage systems in BSMSN during a sudden and/or long, consecutive-days of heavy rainfall. These water sources and open spaces can also serve as disaster resilience measures in case of earthquakes or drought events, as well as, general evacuation sites.
- **Maintenance.** Develop a regular maintenance plan to keep the drainage network, pond, retention areas, permeable surfaces etc. in BSMSN clean and to remove debris and obstructions in order to secure the expected water flows throughout the site.

### 3.3.6 Transport Within BSMSN

#### a. Roads, Bridges and Ports

Enhancing the resilience and reliability of transport infrastructure is crucial to ensuring that investors, residents, and businesses within BSMSN have reliable and direct access to markets, jobs and social services. Transport infrastructure within and adjacent BSMSN - roads, bridges, and ports - are expected to be properly designed and implemented to support the zone's growth through time. Because it is possible that at some point, infrastructure networks along the transport corridors within BSMSN will be exposed and/or become vulnerable to natural hazards, where damages in one segment of the network could cause disruptions to the entire transport network and potentially, negatively affect all/other transport services enhanced resilience measures are advisable. Resilience measures will limit transport disruptions, which can negatively affect firms and households, indirectly cripple supply chains and the movement of goods, hinder employees from commuting to work, and/or inhibit shipments of finished products to the market<sup>17</sup>.

- **Risk considerations.** Transport infrastructure should be sited in areas with low inundation risks. Construction of transport infrastructure must use national and international standards for flood and seismic resilience. The most protective standard should be used within BSMSN. Flood resistance of a 1 in 100-year coastal flood, 1 in 25-year river flood, and protection from historical maximums for pluvial flooding should be used for all transport infrastructure within BSMSN. Note: Seismic and subsidence risks need further assessment when designing roads, bridges and ports.
- **Resilience measures.** Various measures to enhance resilience against floods, earthquakes and transport infrastructure are included in “Enhancing Competitive, Green and Resilient Industries in Bangladesh: Integrating Resilience Within the Design and Costing of BSMSN Economic Zones 2A and 2B Report”, Miyamoto International, 2020.

#### b. Road/Transport Guidelines

Key measures for road/transport resilience for BSMSN include:

- **Structural design.** Structural design must meet international standards to ensure a longer service life. Ensure structural design complies with AASHTO provisions for: i) the thickness of asphalt, ii) the pavement design, and iii) better performance during flooding. Use highest reliability requirements or higher flood probability for increased design life of pavement.
- **Hydraulic path.** Use moisture resistant materials in BSMSN for improved drainage in order to reduce submersion depths and durations during floods
- **Maintenance.** Develop a pavement maintenance system, including preventive care/maintenance to extend the design and life cycle of the road pavement throughout BSMSN.
- **Traffic and truck loading planning and management.** Restrict traffic loads during floods in order to reduce the impacts of flood on road pavement. For truck loading, use large axle loads and truck volumes for design of roads. (Note: Account for heavier loads in the future.) This can minimize wear and tear on BSMSN roads, reduce cracking, ruts, and increase the smoothness of pavement.

<sup>17</sup> From “Rozenberg, Julie; Espinet Alegre, Xavier; Avner, Paolo; Fox, Charles; Hallegatte, Stephane; Koks, Elco; Rentschler, Jun; Tariverdi, Mersedeh. 2019. From A Rocky Road to Smooth Sailing: Building Transport Resilience to Natural Disasters. Background paper for Lifelines. World Bank, Washington, DC. © World Bank. License: CC BY 3.0 IGO.” For more information see: <https://openknowledge.worldbank.org/handle/10986/31913>

- **Pavement types.** The use of a composite or rigid overlay has been proven to reduce flood risks and should be used throughout BSMSN.
- **Structural monitoring.** The use of sensors to monitor and record performance in service and during extreme events is required. This will enable a rapid response in the event of an emergency.
- **Response planning.** Develop a Disaster Response Platform, where information from rapid assessments of damaged roadways could expedite the faster opening of undamaged roads to aid the public. Pre-arranged responses for post disaster road repairs with local contractors could also be integrated within the disaster response and continuity plans.
- **Evacuation routes.** Locate evacuation routes above ground and on publicly accessible land. Ensure their visibility during floods. Provide proper signage to demarcate the location of the evacuation routes. Vertical posts may also be positioned on opposite sides of the roads (at regular intervals), which may be used as marker during emergencies. Establish evacuation time requirements for workers and staffs in BSMSN.

#### c. Bridge Guidelines

Key measures for bridge resilience for BSMSN include:

- **Apply international standards and good practices for the design of bridges.** Ensure design complies with AASHTO provisions and ensure all bridges meet the seismic requirements of modern codes for the design of bridges. Use pile foundation for piers and ensure they extend below the scour and liquefiable levels. Ensure adequate capacity, excluding the resistance of the weak layers. For durability and smoothness of ride, apply a layer of polyester concrete overlay, with a minimum thickness of 25 mm to the concrete deck.
- **Construction and quality management.** Ensure a robust Construction, Quality Management and Supervision Program is implemented throughout BSMSN.
- **Operations and maintenance** - Develop a rigorous Bridge Maintenance Program for BSMSN and maintain all records in a digital format. Address preventive maintenance issues as they arise. Rate the bridge and ensure trucks heavier than the nominal bridge rating are not using the structure.
- **Monitor and collect data for improved design and planning of bridges.** Conduct geo-technical and hydraulics testing on bridge designs, as part of the design process.

#### d. Seaport Risks and Resilience Measures

- **Risk considerations.** Seaport infrastructure is vulnerable to floods, cyclones, strong winds, and earthquake risks due to its location by the water. As a consequence of its vulnerabilities, seaports can experience damages and disruptions, which can have significant economic consequences. Structural damages may include losses and damages to wharfs, jetties, piers, container cranes, and warehouses from floods, earthquakes and/or strong winds.
- **Resilience measures.** Given the importance of the seaport to the economic viability of BSMSN, the ports structure and resilience is critical for the zone's competitiveness and emergency and recovery plan. The redundancy of transportation to the seaport and power supply for seaport facilities is a vital component of BSMSN in order to make the seaport functional during a post-disaster situation.

### e. Seaport Guidelines

Key port related resilience measures include:

- **Site design.** Ensure the soil surrounding the port's wharfs, piers, and container cranes is not liquefiable and has been compacted. Consider the dynamic interaction between the wharf, piers, and cranes and design the port connections to resist applied loading.
- **Application of international good practices.** Use international good practices and the most appropriate international standards when constructing the port in BSMSN. At minimum, a developer should use battered piles with seismic isolators for all wharfs/piers and ensure that the wharf/ pier foundation is embedded in competent soil.
- **Higher seismic and flood design standards.** Ensure that the key port building structures within BSMSN are designed using higher importance and reliability factors for an extreme event such as earthquakes or floods. Ensure that conveyors, such as grain or bulk conveyors are designed to withstand extreme earthquakes and wind forces on the site.
- **Redundancy and continuity planning.** Provide redundancy in roadways connected to the seaport. Provide redundancy and robustness for power supply to seaport facilities against floods and earthquakes.
- **Monitoring.** Use sensors to gather real-time data and monitor water levels, wave heights, wind speeds and directions, etc. and inform the early-warning system in the port area.
- **Disaster risk finance and insurance.** Clarify within the contracts of port operators and owners and between the private and public sectors on mechanisms to finance normal and emergency inspections, repairs and reconstruction costs.

### f. Power, Water, Drainage, Sanitation, and Waste Management Within BSMSN

Core infrastructure within BSMSN includes power, water, drainage, sanitation, and waste management and this core infrastructure is needed to support the daily economic and social activities within the zone. Hence, resilience of these networks must be prioritized within BSMSN. Power, water, drainage, sanitation, and waste management infrastructure are often vulnerable to natural hazards and climate risks such as flooding, earthquakes, and subsidence. Because of potential natural disasters or climate change events within BSMSN: i) drought may reduce the water supply or interfere with desalination, ii) too little sun may negatively affect the solar power generation capacities, iii) temperature fluctuations may influence the efficiency of bio-gas generation from landfills, and/or iv) high precipitation may stress the design capacities of the wastewater or effluent systems. This infrastructure is also subject to hazards risks such as flooding may render a sub-station inoperable or an earthquake may destroy a pipeline. Waste management sites may be flooded, contaminating surrounding areas. If large-scale disaster events occur there could be zone-wide damages, which increases waste generation volumes, often above the daily or overall waste management capacities<sup>18</sup>.

- **Risk considerations.** There are disruption risk considerations associated with core infrastructure such as effluent treatment plants, desalination plants, rooftop and floating solar systems, steam networks, landfills, bio-gas plants, waste sorting areas, and material recovery facilities. Earthquakes,

<sup>18</sup> From Stip, Clementine; Mao, Zhimin; Bonzanigo, Laura; Browder, Greg; Tracy, Jacob. 2019. *Water Infrastructure Resilience : Examples of Dams, Wastewater Treatment Plants, and Water Supply and Sanitation Systems. Background paper for Lifelines*; World Bank, Washington, DC. © World Bank. License: CC BY 3.0 IGO. For more information, see: <https://openknowledge.worldbank.org/handle/10986/31911>

hurricanes, and ensuing floods have caused significant damage to water supply, drainage, sanitation, energy and waste management plants<sup>19</sup>. The issue of flooding is a concern for coastal areas also as they are subject to sea level rises due to climate change<sup>20</sup>.

- **Resilience measures.** For the power, water, drainage, sanitation, and waste management plants in BSMSN such as centralized effluent treatment plant, desalination plant, rooftop and floating solar, steam network, landfill, biogas, waste sorting, and material recovery facility, etc. various flood and earthquake resilience measures can be implemented to continue and improve performance in the face of flooding and earthquakes by reducing losses, damages, and disruption to core infrastructure.

#### g. Power, Water, Drainage, Sanitation, and Waste Management Guidelines

Key resilience measures for core infrastructure include:

- **Structural design.** Elevate key plant buildings and structures above HFL to prevent flood inundation. Use dry floodproofing methods to prevent flood waters from coming into contact with key plant equipment or assets. Dry floodproofing involves constructing flood barriers or shields around individual pieces of equipment or areas that contain essential equipment. The barrier must be high enough to protect critical equipment from floodwater, strong enough to resist flood forces, and sealed properly to control leakage and intrusion of floodwaters. Dry floodproofing measures must also comply with other applicable national codes and standards, such as BNBC 2015.<sup>21</sup>
- **Seismic requirements.** Ensure that all buildings in the treatment plant meet the seismic requirements of the National Code for high-importance categories. Improve the capacity of other infrastructure facilities, especially the power network, which can adversely affect the function of plants, a wastewater pumping system, or a water pumping system.
- **Equipment design.** Avoid placing pumping systems on loose sandy soil with a high groundwater table such as near rivers or waterfronts. Power outages are less likely to severely affect pumping systems or to cause them to fail, if such systems are not in these areas. Ensure that a seismic switch is installed to allow the safe shutdown and restart of systems.
- **Monitoring and maintenance.** Perform routine and regular maintenance on core infrastructure and promptly fix any observed problems.
- **Redundancy and continuity planning.** Increase the redundancy of components like treatment plants through the addition of backup systems. IE. Harvest rainwater to source a back-up water supply.

<sup>19</sup> For example: Hurricane Harvey in 2017 damaged hundreds of water and waste treatment facilities (Sebastian et al., 2017). Similarly, the 2011 earthquake in Japan damaged a treatment plant. Examples of this damage are presented. (Miyamoto International, 2020)

<sup>20</sup> EOS (2017) writes the following for coastal areas of the US, and the same concerns are applicable for BSMSN:

- Flooding from sea level rise disables wastewater treatment plants by filling tanks and critical components with water. That water takes up more and more space in the tanks until it causes the worst kind of traffic jam. Effluent that normally would have been cleaned by the plant gets redirected to the local overflow destination. In New York City, Hurricane Sandy sent 10 billion gallons of sewage into the East River, the Hudson River, and New York Harbor.

Permanent inundation from sea level rise remains on the horizon, but storm surges and coastal flooding are becoming more frequent today. This year, Hurricane Harvey shut down 40 wastewater treatment plants in the Houston, Texas, area. Increased coastal erosion is rasping away what is often a thin strip of land separating many of these facilities from the water.

<sup>21</sup> Reference:

\* Dry flood proofing technique is recommended in the American Society of Civil Engineers (ASCE) 24-14, which is a referenced standard in the 2015 International Building Code® (IBC) and the 2015 International Residential Code® (IRC). [https://www.fema.gov/media-library-data/1436288616344-93e90f72a5e4ba75bac2c5bb0c92d251/ASCE24-14\\_Highlights\\_Jan2015\\_revise2.pdf](https://www.fema.gov/media-library-data/1436288616344-93e90f72a5e4ba75bac2c5bb0c92d251/ASCE24-14_Highlights_Jan2015_revise2.pdf)

FEMA, 2013. Reducing Flood Effects in Critical Facilities.

[https://www.fema.gov/media-library-data/1381404651877-](https://www.fema.gov/media-library-data/1381404651877-881a2cf70a90ac63b9c067100ffccace/SandyRA2CriticalFacilities_508_FINAL2.pdf)

[881a2cf70a90ac63b9c067100ffccace/SandyRA2CriticalFacilities\\_508\\_FINAL2.pdf](https://www.fema.gov/media-library-data/1381404651877-881a2cf70a90ac63b9c067100ffccace/SandyRA2CriticalFacilities_508_FINAL2.pdf)

Minimize the possibility and effect of, cascading failures by introducing emergency shutdown procedures for different failure scenarios. Ensure that components of treatment plants cannot be so severely damaged that they then affect the function of an undamaged treatment plant. IE. Minimize the amount of pressure pipes exposed to flood waters. If a natural disaster occurs, conduct an intensive post-inspection to detect all damage to power, water, drainage, sanitation and wastewater pipelines within the affected area of BSMSN.

#### h. Telecommunications Within BSMSN

Telecommunications and the internet have become essential infrastructure within economic zones. Therefore, the disruptions of telecommunication services will cause significant negative economic and social impacts for BSMSN. Telecommunication systems for zones are often comprised of expansive backbone networks with cables, internet exchange points, data centres, and wireless transmission infrastructure such as towers and antennas, etc. Data centres and landing stations are particularly vulnerable to flooding and earthquakes because of the large quantities of ICT equipment involved in their operations. Similarly, cables, which often run along existing connectivity routes (energy and transport) can also be at risk of inundation. Given that telecommunication networks often carry important data and information, in case of disasters, they can serve as important tools for decision-making related to emergency response and business continuity. Therefore, the ability of telecommunication infrastructure to avoid disruptions and continue its services under growing climate and disaster risks is an important resilience measure.

- **Risk considerations.** Earthquakes, hurricanes, and ensuing floods have caused significant damage to telecommunication infrastructure and have caused operational downtime and financial losses. In 2012, Hurricane Sandy caused significant damage to telecommunication hubs in the eastern part of the United States. Similarly, the 2011 earthquake in Japan destroyed/ damaged over 40 central offices, 6,000 aerial cables, and 65,000 telephone poles (EMI, 2013).

**Resilience measures.** Given the importance of the telecommunication sector to the development, operational capacity, and economic viability of BSMSN, measures to support flood and earthquake resilience of its telecommunication infrastructure is very important. Especially, if an emergency power facility is connected to other infrastructure networks. In this instance, it is important that sufficient power for continuous service of the telecommunication system, urgent communications, and emergency data backup networks are secured.

#### i. Telecommunication Guidelines

Key telecom measures for resilience for BSMSN include:

- **Structural design.** Treat buildings as critical structures, (considering their importance factor) which must remain operational in the aftermath of a natural disaster. Elevate these key telecommunication buildings above the high flood level (HFL).
- **Equipment design.** Implement special requirements for the design of all equipment and their anchorage to the building. Provide robust conduits for cables against flood and earthquake. Place all electrical equipment in the buildings above the HFL. For underground cables, use seismic resilient conduits with flexible joints to allow for the movement of the ground without failure. Only use seismically-qualified electrical components. Ensure all cable trays, racks, and duct banks are designed for forces of extreme events. When concrete conduits are used, ensure they are reinforced. When the ground water is high, add additional weight at the bottom of the conduit to counteract buoyancy forces.



- **Redundancy and continuity planning.** Provide redundancies in the system in order to keep continuous telecommunication service open. Develop a disaster response protocol, including an early warning system for BSMSN’s telecommunication system.

#### j. Buildings Within BSMSN

Enhancing the resilience of buildings is critically important within BSMSN. Traditionally, buildings are designed and erected as structures to protect people and assets from the external environment. Depending upon the function of a building, it is important to implement targeted or fit-for-purpose resilience measures and options. The ability of core buildings to withstand and provide shelter in the face of increased climate and disaster risks is important.

Within BSMSN, various types of buildings for various sectors/uses are expected, including, but not limited to, factory shells, warehouse and manufacturing facilities, administration buildings, residential buildings, fire stations, schools, medical centres, commercial and retail areas, etc. Buildings in the precincts of BSMSN all have different functions and user groups, and consequently, their needs and objectives for resilience will vary. For example, school buildings in Precinct A will need to provide safe and comfortable learning environments for their students but may also need to serve as evacuation centres for other precincts within BSMSN when facing a disaster event. Therefore, to enhance resilience, it is important for school buildings throughout BSMSN be designed in ways in which residents, workers, and visitors alike can safely take refuge if faced with a climate or natural hazard episode. Large factory buildings, on the other hand, may include buildings that house people and high value equipment and products, as well as buildings for activities with lower productivity or assets. Therefore, not all factory buildings need to be built at the highest resilience standard with advanced flood protection measures or land stabilization measures. Hence, understanding and prioritizing the risks and resilience requirements are very important when it comes to designing effective solutions to the enhance resilience of buildings.

- **Risk considerations.** For buildings, both flood and earthquake hazards are important and require consideration. The building code in Bangladesh, (BNBC 2015), is a robust code based on international standards (such as ASCE 7-10). Accordingly, buildings designed and built according to the code provisions are expected to perform satisfactorily when subjected to the level of hazard (wind or earthquake) for which they are designed. The code provides prescriptive requirements for structural design of buildings, including loads to be considered. For floods, the code considers two design floods for computing the maximum flood elevation, surge height, and wind velocities: i) a 100-year return period for essential structures and ii) a 50-year flood for other structures.

Regarding earthquake-resistant construction, BNBC (2015) states: “The purpose of earthquake-resistant design provisions in this Code is to provide guidelines for the design and construction of new structures subject to earthquake ground motions in order to minimize the risk to life for all structures, to increase the expected performance of higher occupancy structures as compared to ordinary structures, and to improve the capability of essential structures to function after an earthquake.” It further sets forth structural guidance on enhancing the design and construction of earthquake resistance buildings.

- **Resilience measures.** Various technical analysis and measures to enhance flood and earthquake resilience of building are included in “Enhancing Competitive, Green and Resilient Industries in Bangladesh: Integrating Resilience Within the Design and Costing of BSMSN Economic Zones 2A and 2B Report,” Miyamoto International, 2020.

### k. Building Guidelines

Key resilience measures for buildings within BSMSN include:

- **Site design.** Site design should comply with the latest version of the Bangladesh Economic Zones Rules, 2017 (Construction of Buildings or S.R.O No. 46-Law/2017). Rainwater harvesting systems must be incorporated into all building design in BSMSN to ensure continued water supply in buildings and facilities during disasters, while also using collected rainwater during normal times to decrease utility costs.
- **Structural design.** Ensure that the structural design of buildings for earthquakes and floods within BSMSN complies with the BNBC 2015 provisions for longer building service cycles. Use the higher performance (such as flood with a higher return period) for designing against natural disasters. Use stronger materials for better performance, which may initially be a higher investment but will lower the lifecycle costs by requiring less need for reconstruction or retrofitting at a later date.
- **Site improvement.** Ensure that soil compaction, deep foundations, and soil improvements are undertaken in BSMSN in order to reduce settlement and liquefaction. Provide anchorage and bracing for non-structural components. Use deep foundations for liquefiable sites within BSMSN.
- **Enhance functionality.** Place all sensitive electrical equipment above flood elevations/levels in BSMSN and add non-structural components such as anchorage and bracing. This will keep buildings operational, achieve higher occupancy standards, and enable buildings to serve as shelters, in face of disaster events.
- **Monitoring and maintenance.** Within BSMSN, schedule regular building/infrastructure/utility reviews and monitor inspections of construction in order to reduce maintenance costs and create a safer building structure. Develop a preventive maintenance program for all buildings, including periodic inspections. Ensure all records are maintained electronically and create an asset management system for all projects. Use sensors to monitor and record performance in service and during extreme events.
- **Emergency response and continuity planning.** Rapid response in the event of an emergency can reduce downtime in BSMSN. Hence, it is mandatory to develop a Post-Disaster Damage Assessment and Recovery Program for BSMSN and train staff on how to undertake post-disaster damage assessments.

Please see **Annexure 3.1:** Analysis of Flood and Seismic Resilience of Flood Protection and Management infrastructure and Site Development and **Annexure 3.2:** Infrastructure Resilience and Performance Enhancement Measures

An aerial photograph of a road with a red and white striped median, serving as a background for the text.

***4. Infrastructure  
Development Plan  
For BSMSN***



# 4. Infrastructure Development Plan for BSMSN

Chapter IV examines the transport infrastructure required for BSMSN overtime and outlines the key off-site and on-site infrastructure/utility networks needed for the zone to thrive. In addition, this chapter contains recommendations regarding the medium and long-term transport/infrastructure/utilities requirements/expansion for proper growth of the zone.

## 4.1 Transport Network

### 4.1.1 Overview

In order to make BSMSN a multimodal transport platform comprising of roads, seaport, rail connections and linkages to Chattogram airport, a full transport/traffic assessment was undertaken. A review of upcoming transport projects/improvements was analyzed and traffic projections were made for BSMSN over the next 20-years. Details are presented in the BSMSN Report Part III.

#### a. Road Network

The regional and local road networks surrounding BSMSN are critically important as they are the roads, which will carry and transfer cargo and passenger traffic on and off the zone. At present, the capacity of the local access roads adjacent BSMSN are quite limited and the number of existing links into BSMSN are inadequate to cater to the new volume of traffic likely to be generated by BSMSN. Hence, the road network will need to be upgraded and improved. Considering the functional characteristics of BSMSN and the anticipated movement pattern of passenger and freight, Dhaka – Chattogram Highway (N1) and Feni – Sonagazi Road are likely to assume greater importance, especially for predominant north – south movement. The connecting roads are mainly from Dhaka Chattogram Road and can be listed as;

- Muhuri Project Road (Zorarganj to Muhuri Project)
- Bamonsundar Road
- Sheikh Hasina Sarani
- Mohan Nagar Barodarogarhat Road

No significant link is found on the northern side connecting Feni Sonagazi Road / Sonagazi Companyganj Road.

#### b. Rail Way Network

The BSMSN area is not directly connected by rail. The Dhaka-Chattogram railway line running almost parallel to the highway (N1) is about 10 Kms from the proposed site. The railway stations in the vicinity are Barotakia, Mirsarai and Sitakunda.

#### c. Water Transport

No waterway is presently available for BSMSN. The nearest ferry service is at Kumira located around 15 Km away from the southern end of the site. The ferry service is mostly used for passenger transportation to/ from Sandwip Island.

#### d. Port Facilities

Chattogram Port is about 67 Km from the site by road and about 85 Km by sea.

#### e. Air Network

The nearest airport is at Chattogram (Shah Amanat International Airport) located about 79 Km away from the site by road.

#### 4.1.2 Transport Assumptions

The transport plan has been prepared based on the anticipated traffic impact on the off-site and on-site road network. The following are the key assumptions used to determine the traffic projections/improvements for Regional roads outside BSMSN through 2040:

- Employment in each shift has been taken as 40% of total (lower employment in night shifts).
- With staggering of working hours one-way traffic from/ to the study area is considered as 40% of each shift.
- 65% of total direct and indirect employment would move from / to eastern side (Dhaka Chattogram Road) and the rest towards Sonagazi side.
- Considering the workers commuting from outside, only 10% of peak hour passenger traffic has been loaded on Dhaka Chattogram road.
- 80% of freight traffic will move along Dhaka Chattogram Road and the rest through Feni Sonagazi Road.
- 10% of goods traffic will move during worker peak hours and rest during freight peak hours along with normal projected traffic.
- The average worker / freight peak hour traffic considered as 5% for both the roads, though normal peak traffic varies between 6% and 8%.
- Long term annual traffic growth rate is considered as 5%.
- The freight traffic generation (production and attraction) from production units would be 8 truck trips per hectare area of firm.
- 15% of truck trips would be made through new road connectivity from southern end (connecting Chattogram), by railways and waterways.

Based on these assumptions the maximum one-way passenger traffic by 2040 towards Dhaka-Chattogram Road and Sonagazi will be around 9,000 PCU/hour and 3,200 PCU/hour respectively. The freight traffic by road would be 5,513 PCU/hour by 2040.

### 4.1.3 Proposed Transport Network of BSMSN

#### a. Regional Transport Network and Multimodal Transport System

The BSMSN will house a huge number of industries along with employees and resident population. To meet the transport demand for passengers and goods, it would be appropriate to build a multimodal transport system in BSMSN combining waterways, seaports road and railway connection. The Integrated Multi-Modal Transport Policy of Bangladesh focuses on:

- Integration within and between different types of transport modes,
- Integration with the environment so that transport choices support a better environment,
- Integration with land use planning at national, regional and local levels.

The following are the most critical improvements to the transport system, which have been prioritized to support BSMSN:

#### The Road Network

- Access to the northern side of BSMSN will be from Sheikh Hasina North Road (Bhangi Road). Because the current road network will not be able to handle future transport demand, roads to Sonagazi will need to be expanded/improved. As such, a 6-lane bypass for Sonagazi has been suggested from Precinct A. For the Feni - Sonagazi Road, the present two-lane road is not adequate, hence will require widening to a 4-lane road in the medium term.
- The traffic volumes from the access roads connecting Dhaka-Chattogram Highway will be inadequate by 2025. As such, the highway will need to be upgraded and widened. For proposed freight/cargo traffic, a separate access-controlled link from the Dhaka-Chattogram Highway connecting to the port and logistic area in BSMSN (Precinct G) will be required.
- The proposed Dhaka Chattogram Expressway will be located approximately 80m west of the present highway (N1). Though some amount of regional traffic will be shared by the expressway, the present 4-lane highway is required to be widened to 6-lanes. Moreover, in order to have direct connectivity to Chattogram from BSMSN, a new link is proposed. This road will start near the Port (Precinct G) and follow the coast down to Chattogram. This will reduce pressure on Dhaka Chattogram Highway and create a special link for a future mass transit solution. To further support industrial development, it is proposed that this road be extended to both the Maheshkhali and Anwara EZs. This is critically important to help support this new Economic Corridor in the region.

#### The Rail Network

- In order to seamlessly facilitate the movement of goods in/out of BSMSN, a rail spur is required. The rail link would initiate from the existing railway corridor adjunct the National Highway (N1), and enter BSMSN parallel to the port and logistic areas proposed in Precinct G. A cargo station within the port/logistics area is also proposed to allow goods to be transferred conveniently and efficiently. In the long-term, this rail spur will be expanded southwards along the waterfront to Chattogram / Chattogram Port/ Maheshkhali and Anwara. This will help strengthen the new Economic Corridor in the region.

### **Railway Station and Bus Terminal**

- To support the workers/visitors coming to BSMSN, the existing railway station along the Dhaka-Chattogram Highway in the vicinity of BSMSN, will be renovated and expanded. In addition to supporting the existing railway line, the station will also support a bus terminal. This terminal will provide 24/7 bus access to all precincts within BSMSN and there will be bus drop-off/pick-up centers in each precinct.

### **Airports**

- In the short term, the Chattogram International Airport – Shah Amanat International Airport, (in its current form) is able to support BSMSN and its requirements. The Chattogram airport however, will need to be expanded and upgraded in the medium-term in order to support the increased number of people and cargo movements from BSMSN and Mosheshkhali EZs. In the long-term, a local airport in close proximity to BSMSN may be required. A feasibility study for an airport must be undertaken before a site is selected. Any new airport must remain outside the BSMSN boundaries and away from the residential precincts. Noise and height considerations must be used when determining the location of a new airport in close proximity to BSMSN.

### **Port Facilities**

- A public port (open to all) within BSMSN - bulk or container – with associated logistics facilities would bring significant value to the zone. A public port could help minimize the congestion and delays currently experienced at the Chattogram Port and decrease transport and logistics costs for investors within BSMSN. For the seaport to function efficiently, the draft in the port must be increased to 9.5m from 6.5m and maintained to allow for 30,000-ton capacity ships to use the port facilities.

### **A Mass Transportation System**

- It is anticipated that short-term traffic demand within BSMSN can be supported by the proposed road network in the Master Plan. However, as a medium to long-term solution, a phased mass transit system such as a People Mover / Light Rail Transit (LRT)/or equivalent from Precinct A to Precinct I will be required. To facilitate this in the future, a 20m strip of land is to be kept as a road reserve to support this activity.

### **A Logistic Area**

- In order to optimize the movement of goods, improve efficiencies and reduce the costs of transport/cargo, a logistics center/Inland Container Depot (ICD) near the port, rail spur, and arterial roads is proposed in Precinct G of BSMSN. It could be comprised of warehouses, rail yard, open storage space for vehicles, administrative buildings with offices, exhibition space and training/ business centres etc. Within this location, trucks and trailers could be accommodated away from the port.



The proposed transport master plan for the region and within BSMSN is shown in **Table 4-1** and **Figure 4-1**.

Table 4-1: Regional Transport Network Improvements

Transport Network	Network Improvements					
	Width	Maximum Capacity in One Direction	Improvement Requirement	Maximum Capacity in One Direction	Proposed Year of Improvement	Vehicle Type Movement
<b>Eastern Part Roads</b>						
Muhuri Project Road	Single	200	Widen to 2-lane	1050	By 2025	Passenger
Baman Sundar Road	Single	200	Intermediate lane with development of nearly 2 Km of missing link	600	By 2025	Passenger
Sk Hasina Saroni	4 Lanes (Under Construction)	4500	Widen to 6-lane	8500	By 2030	Passenger and Goods
Barodarogar Haat Road	Single	200	Partly New Alignment- 2 lane	1050	By 2030	Passenger and Goods
Kumira Road	Intermediate	600	New Alignment- 2 lane along Kumira Canal	10500	By 2030	Passenger and Goods
Dhaka Chattogram Highway (N1)	4Lanes	4500	Widen to 6-lane	8500	By 2030	Passenger and Goods
New Road-2 lane-3Km north of Sheikh Hasina Saroni	-	-	-	1050	2-lane road by 2030	Passenger and Goods
New Road- 4 lane – 3 Km south of Sheikh Hasina Saroni – Port Connector	-	-	-	4500	4-lane road by 2030	Passenger and Goods
<b>New Link from Existing Railway line</b>	New railway link to connect logistic hub and port. It will be extended southwards to connect Bay Terminal and Chattogram Port independently or merging with existing tracks.					
<b>Northern Part Roads</b>						
Muhuri Project-Sonagazi-Companyganj Road	Intermediate	600	Widen to 4 lane	4500	2-lane road by 2025 ; 4-lane road by 2035	Passenger and Goods
Char Chandia Road	Single	200	Widen to 2 lane	1050	2 lane by 2025	Passenger
Islampur	Single	200	Widen to 2 lane with	1050	2 lane by	Passenger

Transport Network	Network Improvements					
	Width	Maximum Capacity in One Direction	Improvement Requirement	Maximum Capacity in One Direction	Proposed Year of Improvement	Vehicle Type Movement
Miazir Dokan Road			partly new alignment		2025	
New alignment-6 lane-Sonagazi Bypass	-	-	-	8500	4-lane road by 2030 ; 6-lane road by 2040	Passenger and Goods
Feni Sonagazi Road	2 Lane	1050	Widen to 4 Lane	4500	4 Lane by 2020	Passenger and Goods
<b>Southern Part Roads</b>						
Sheikh Hasina Saroni - South((Beri Bandh Road)	4 lane-Construction in progress	4500	Widen to 6 lane and extend southwards till Chattogram Port through Port Link Road and Coastal Road	8500	6 Lane by 2035	Passenger and Goods
<b>Sea Port</b>	To be located in Precinct G along with logistic support					
<b>Airstrip</b>	Outside the boundaries of BSMSN					

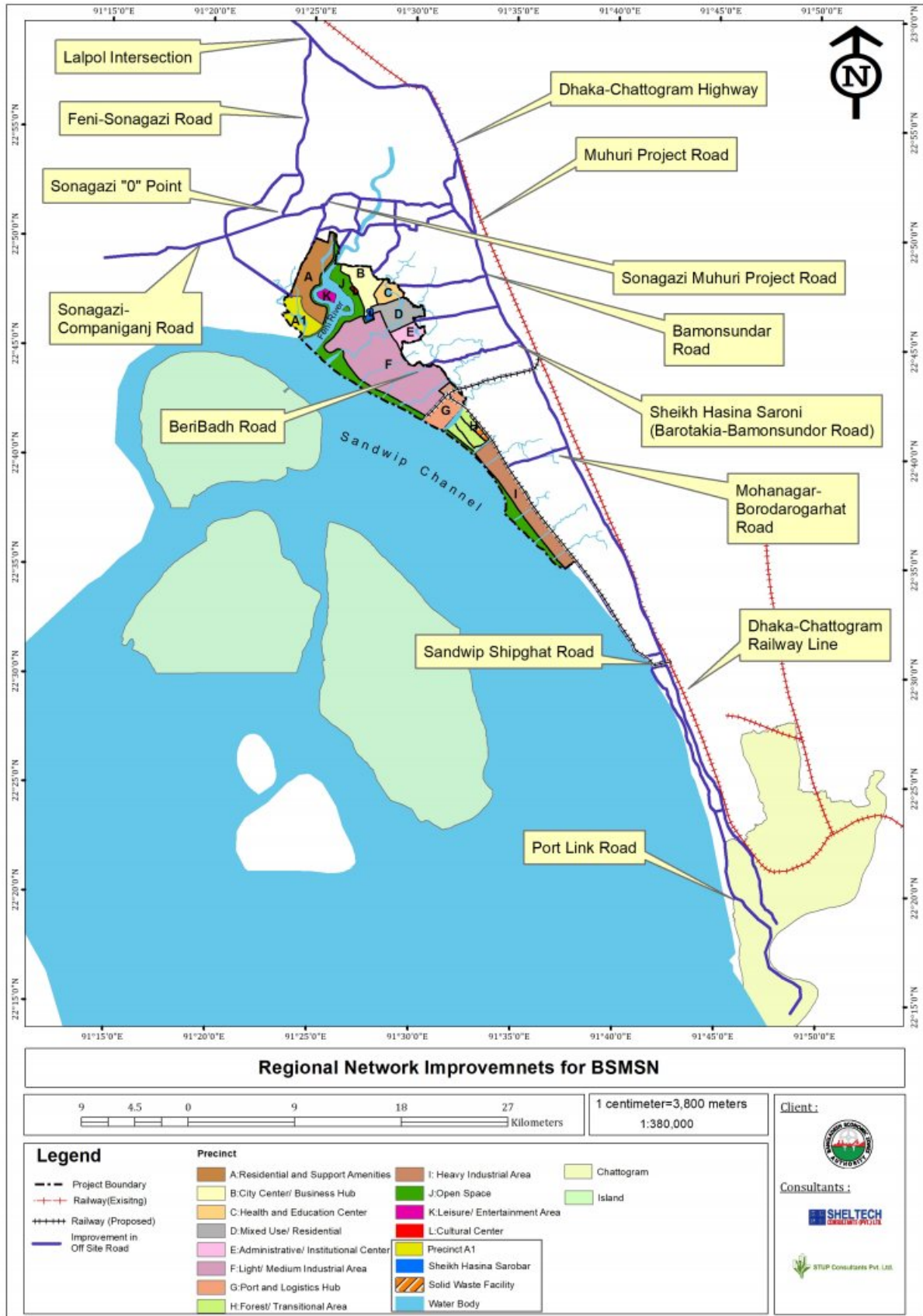

Figure 4-1: Regional Network Improvements for BSMSN

**b. On-Site Road Network within BSMSN**

**Hierarchy of Roads and Cross Sections**

- A hierarchy of roads has been designed within BSMSN, with the intent of: i) segregating urban and industrial traffic to improve safety within the zone, ii) introducing an arterial road network in a grid pattern (as much as possible) to reduce congestion, and iii) constructing secondary roads to improve access to investor projects and plots. All road networks will have services and utilities integrated into their design.

The hierarchy of roads within BSMSN are:

- **An Emergency Road - Super Dyke (100m ROW).**<sup>22</sup> Road on the high embankment along the sea side offering limited access and acts as an emergency exit from BSMSN, if required.
- **Arterial Roads - Type A (100m ROW).** <sup>22</sup>For traffic moving along the periphery of BSMSN to have quicker access to Precincts .
- **Arterial Roads - Type B (60m ROW).** For through traffic on a continuous route within BSMSN.
- **Sub Arterial Roads - Type A (40m ROW).** For collection and distribution of traffic connecting to the arterial road network, however offering a lower level of service than an arterial road.
- **Sub Arterial Roads - Type B (30m ROW)** For collection and distribution of traffic connecting to the arterial road network, however offering a lower level of service than an arterial road. Providing access to large plots of land within Precincts F, G, H and I.
- **Collector Street - (20m ROW)** For collection and distribution of local traffic and providing access to arterial and sub arterial road. Most common in Precincts A, B, C, D, E, and K.

The roads for BSMSN must be designed to international and green resilient standards. The roads will be constructed using existing materials availability in Bangladesh. Stage construction has been adopted for design of pavement thickness of flexible pavement. The bituminous thickness will be designed for a 10 year period and base and sub-base will be designed for the full design period of 20 years. The minimum pavement layers are shown in **Table 4-2**.

*Table 4-2 Minimum Pavement Layers*

Pavement Layers	ROW: 100m/ 60m/ 40m/ 30m	ROW: 20m
Wearing Course (mm)	50(PMB)	40(60/70)
Binder Course (mm)	110(PMB)	60(60/70)
Granular Base-Upper (mm)	250 mm	250 mm
Granular Sub-Base (mm)	250 mm	250 mm
Sub-Grade (Min 8 % CBR)	500 mm	500 mm
Embankment Soil of 500mm (Min 6% CBR)		
<b>Total</b>	<b>1,160 mm</b>	<b>1,100 mm</b>

The road network plan is shown in **Figure 4-2**. As discussed above, the road network within BSMSN will be constructed to international standards with an integrated services /utility system. In Precincts A, B, C, D, E and L all drainage systems along roads will be covered. The following road cross sections with detailed

<sup>22</sup> As per discussions held with BEZA regarding the emergency road, only 55m out of 100m ROW is usable, where provision of a four lane dual carriage way will be sufficient and rest of the area will be kept on reserved. Besides Northern part of Arterial -Type A road (100m ROW) is decreased to 90m ROW due to unavailability of space (Please See Figure 4-8).

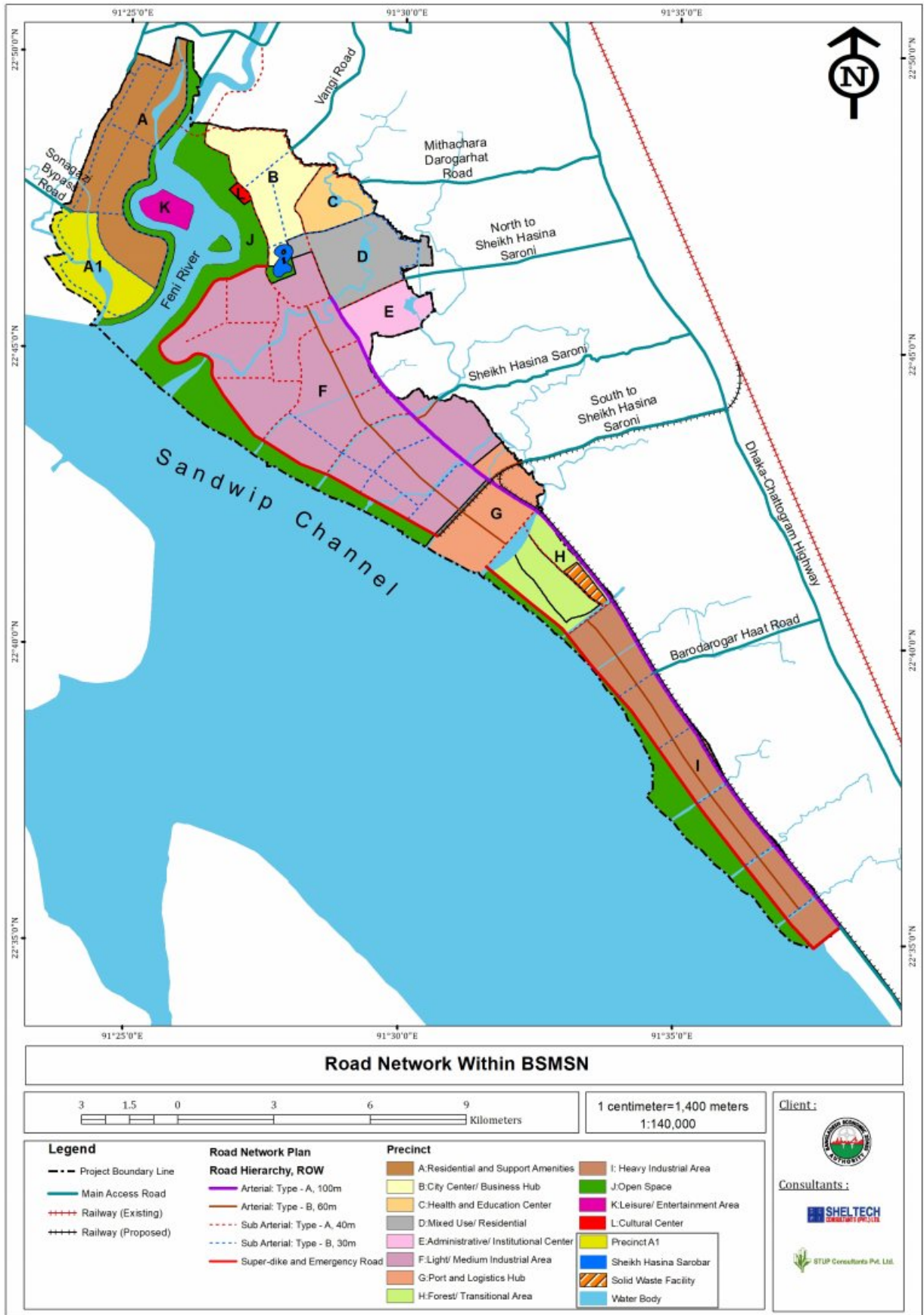

Figure 4-2: Road Network Within BSMSN

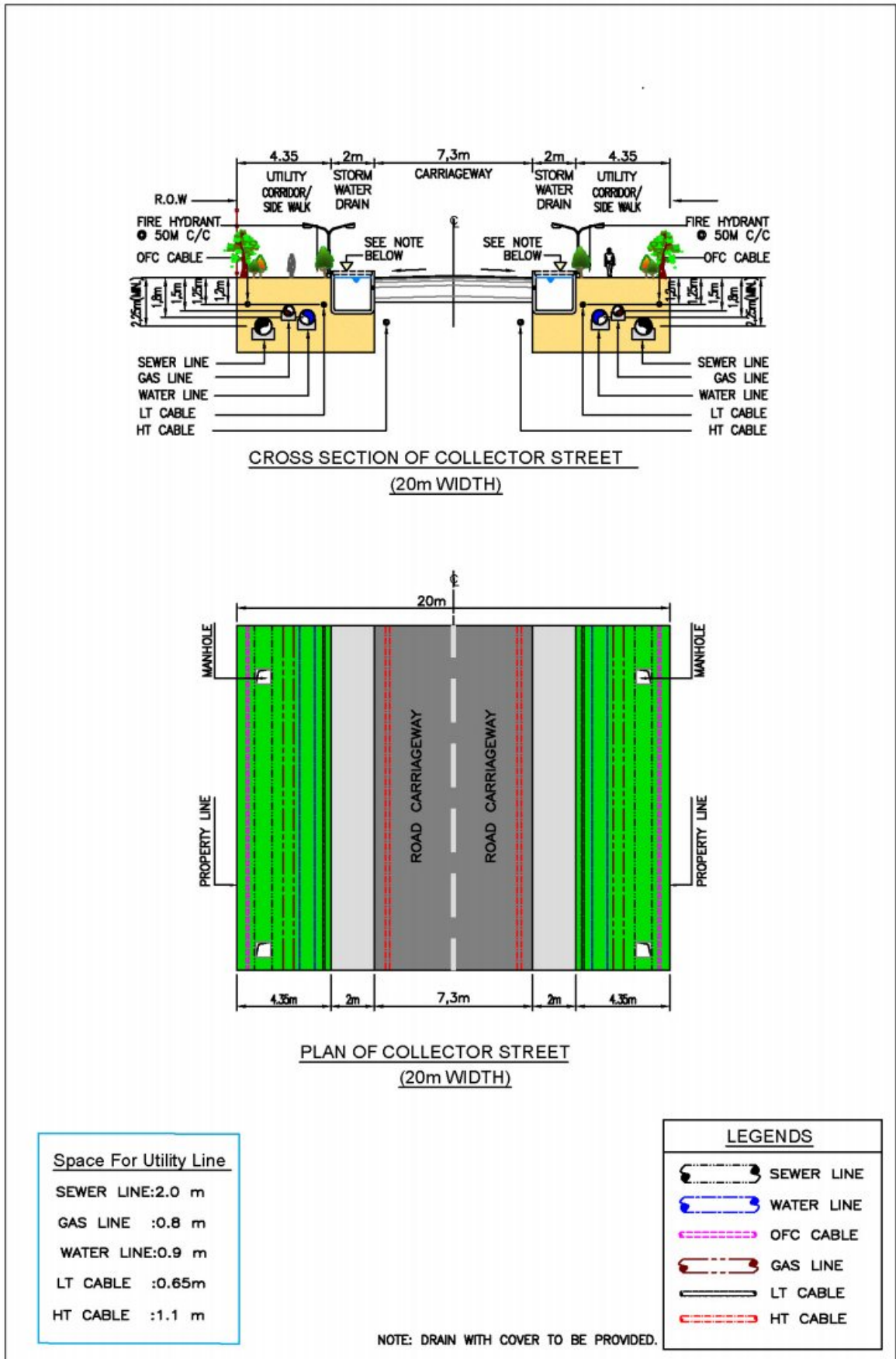

Figure 4-3: Cross section and Plan of 20m ROW Collector Street

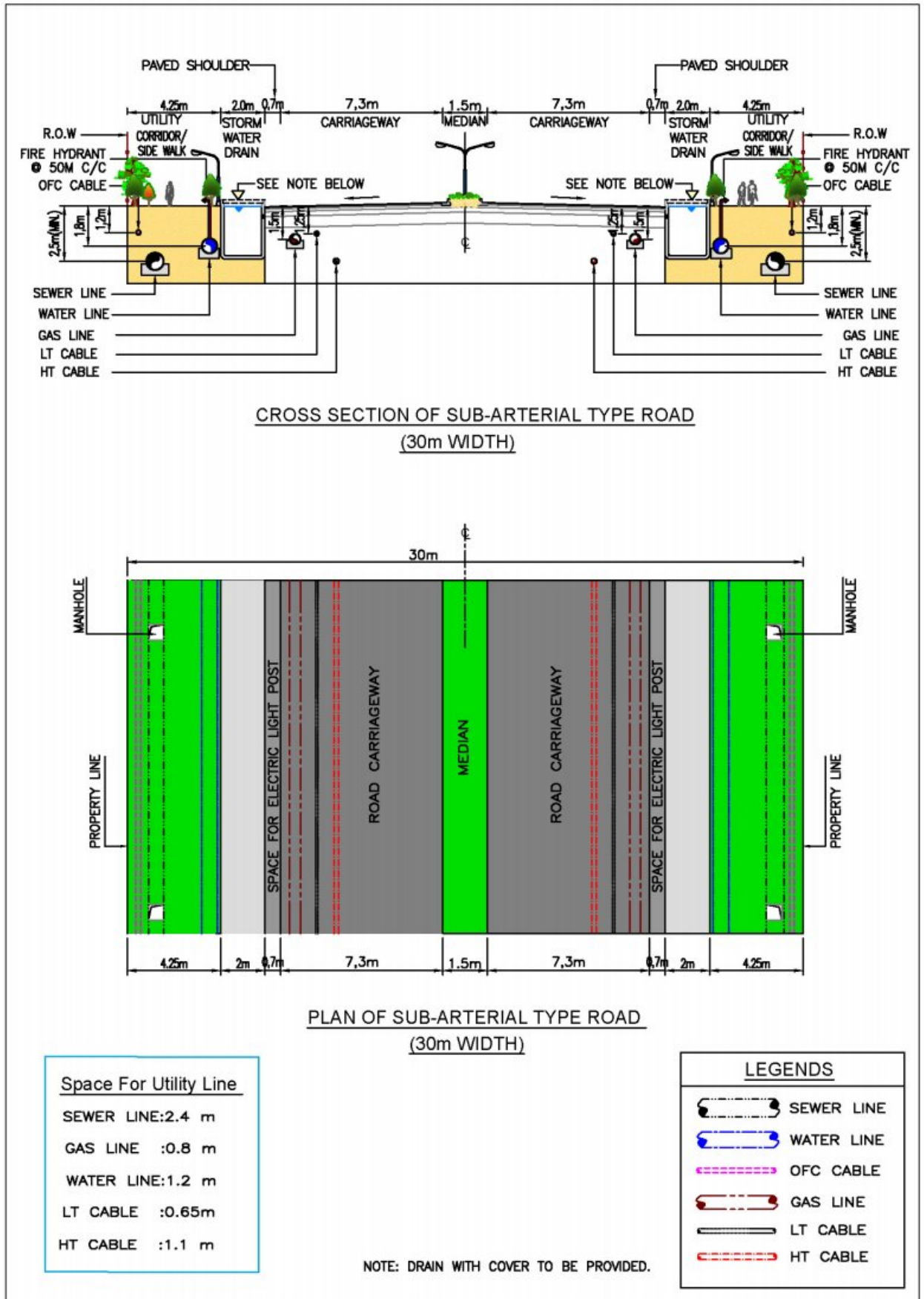

Figure 4-4: Cross section and Plan of 30m ROW Sub-Arterial Type Road

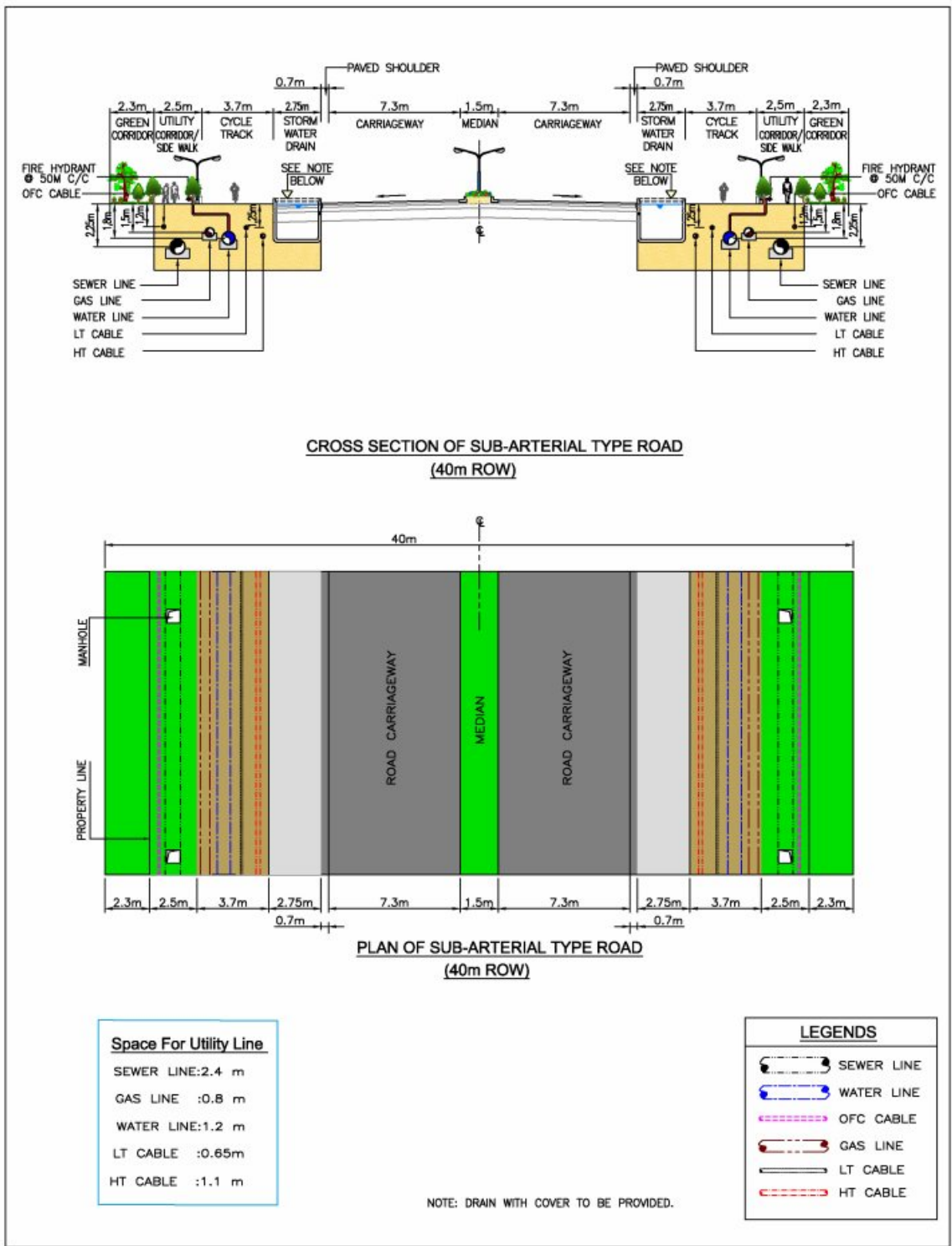

Figure 4-5 Cross Section and Plan of 40m ROW Sub-Arterial Type Road



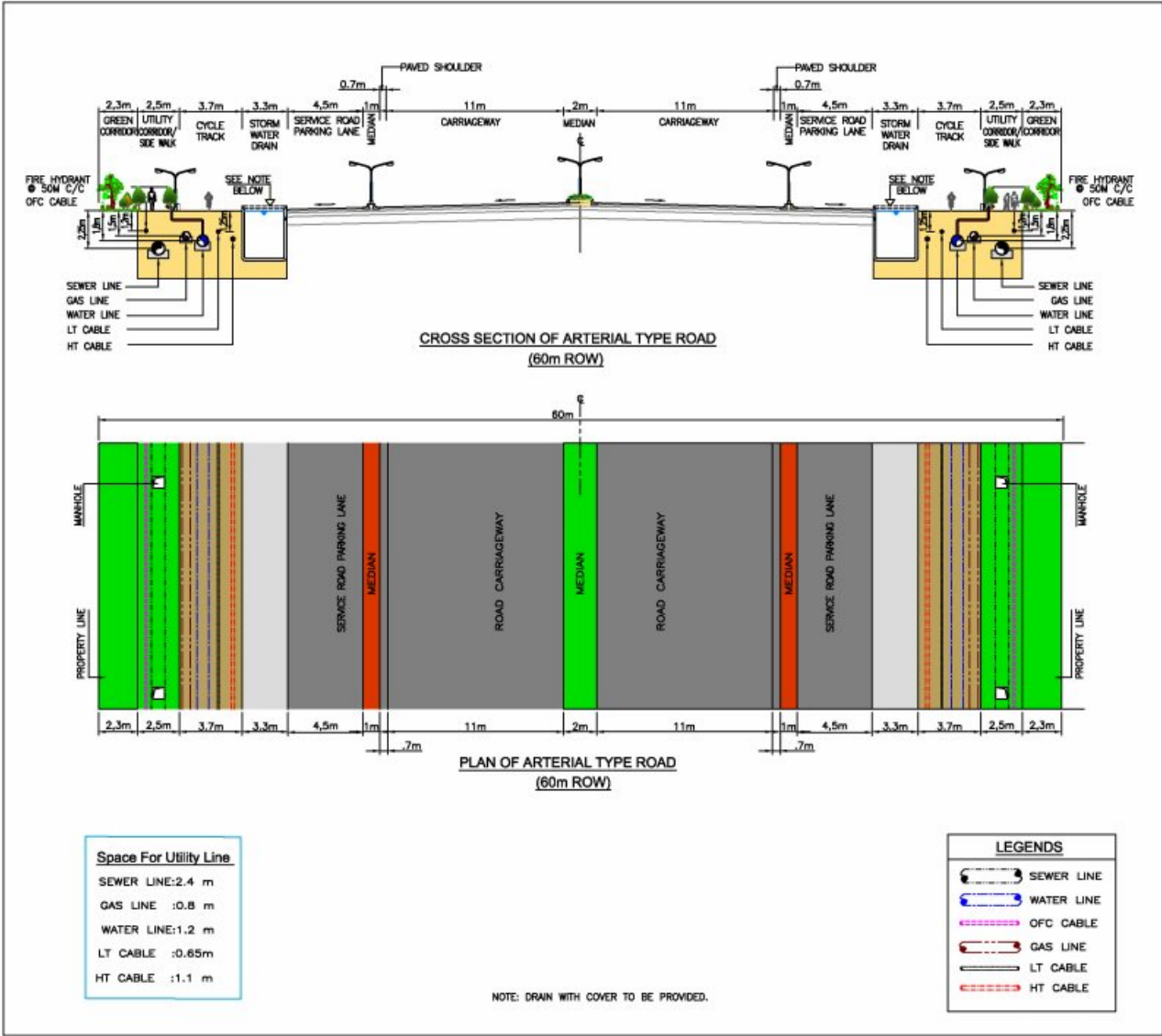

Figure 4-6 Cross Section and Plan of 60m ROW Arterial Type Road

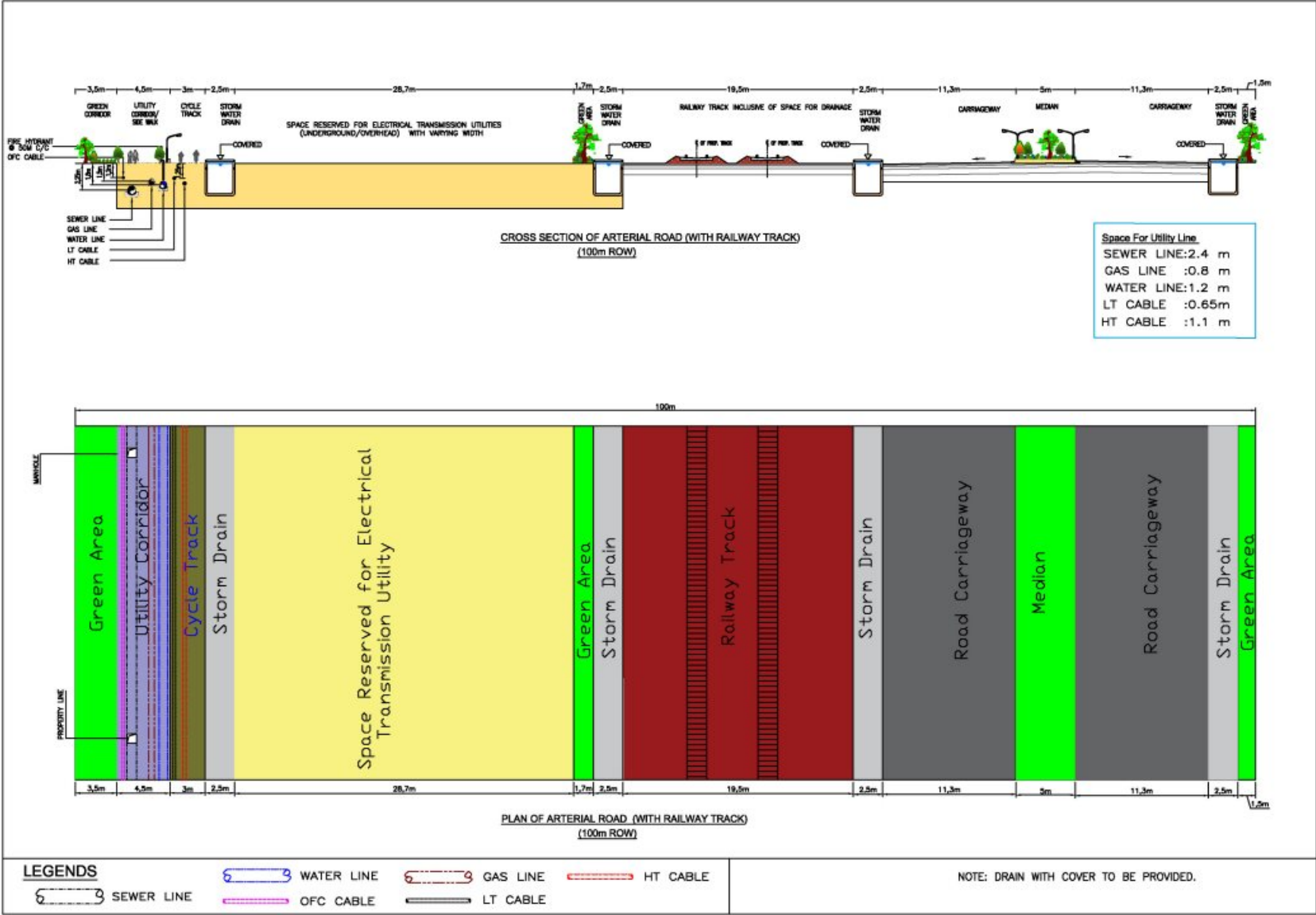

Figure 4-7 Cross Section and Plan of 100m ROW Arterial Road (with Rail Track)

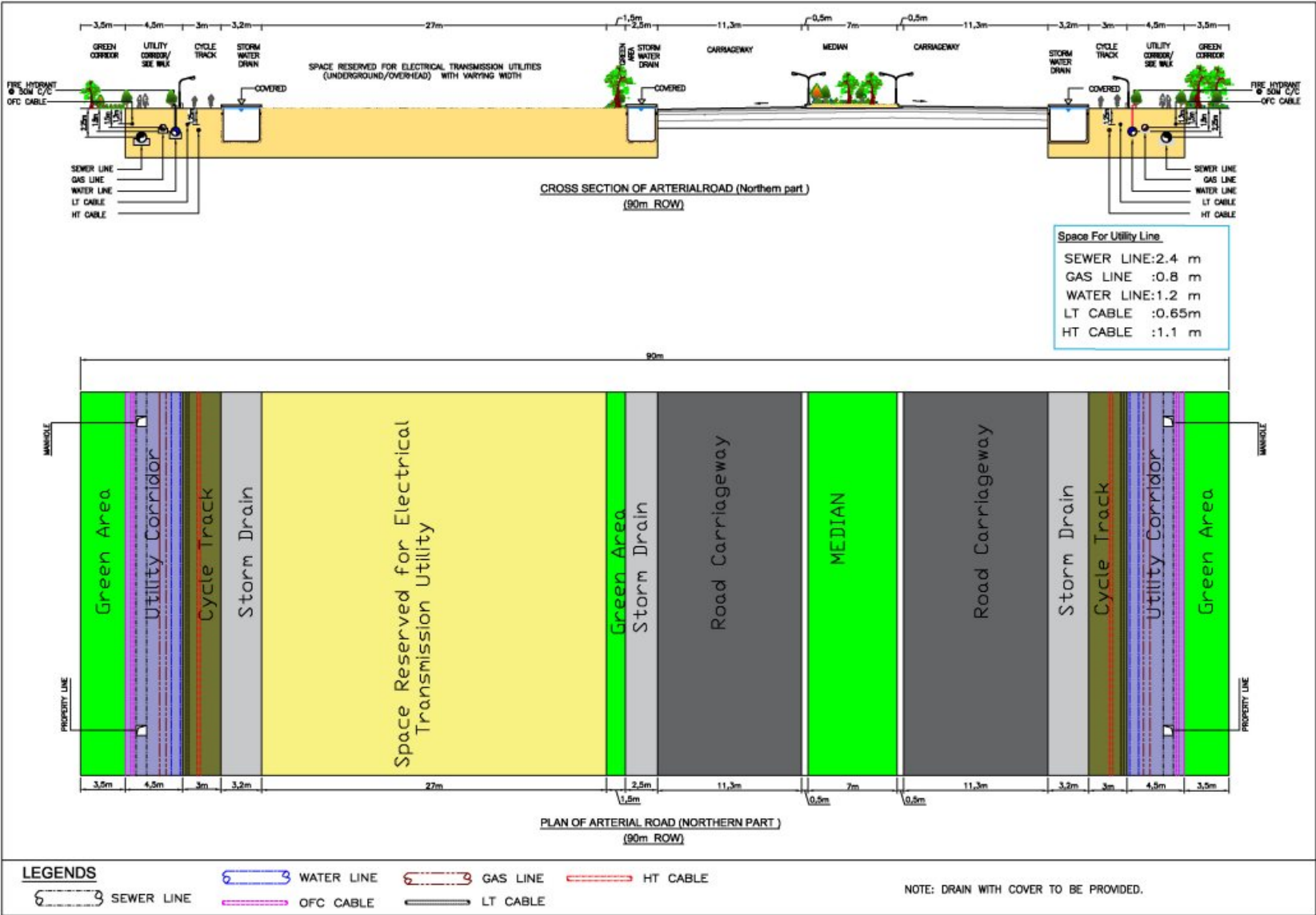

Figure 4-8 Cross Section and Plan of 90m ROW Arterial Road (Northern Part)



utility placement within the ROW is shown in **Figures 4-3 to 4-8**. The dimensions of the cross-section components may undergo some changes during implementation to accommodate the utilities and services.

It may be noted that one of the major focal area in the planning will be pedestrians. Footpaths along the road has been provided with adequate width over the utility corridor. This area will be preferably constructed with interlocking paver blocks for easy maintenance of the facility as well as the utility corridor. It is a fact that most pedestrian crashes occur while attempting to cross the road. One effective way of preventing crashes between vehicles and pedestrians is providing at grade pedestrian crossings with signals or placing them at different levels. In the present situation, where pedestrian crossing signals would cause congestion or crashes (due to high traffic speeds), a grade separated pedestrian crossing, such as an overpass or an underpass, may be used. In BSMSN provision of underpass will not be a good option, as water table is high and is susceptible to flooding. Hence the following measures will be taken for safety of cross – pedestrian traffic;

- At-grade pedestrian crossing at signalised intersections with low/ moderate traffic volume.
- Pedestrian overpass at heavily traffic corridors where pedestrian - vehicular conflict is significant.
- Extensive ramping to accommodate wheelchairs and bicyclists and elevators to increase the usage.
- Should be well-lit and patrolled and spaced conveniently to be availed within acceptable distance of users.

### c. Intersections and Interchanges

The critical locations outside BSMSN where grade separated facilities or interchanges will be required are;

- Intersection of Sheikh Hasina Avenue with Dhaka Chittagong Road (3 arm)
- Intersection of Port connector with Dhaka Chittagong Road (3 arm)
- Intersection of Sheikh Hasina Avenue at CP More (4 arm)

The three-arm intersection of Sheikh Hasina Avenue with Dhaka Chittagong Road will assume very high importance for movement of passenger and freight traffic. The traffic volume to and from BSMSN will be quite high almost throughout the day. Provision of an at-grade intersection at this location will not be sufficient to cater to the anticipated traffic volume, which will result in congestion and confusion. Moreover, Dhaka Chattogram Expressway will run almost parallel and in close proximity to existing Dhaka Chattogram Road, which will further aggravate the situation. Constructing an interchange for turning movements covering both highway and expressway may be difficult due to paucity of space. In that situation, the portion of the proposed expressway (covering BSMSN influence area) is to be elevated with very limited access and a trumpet interchange is to be provided along Dhaka Chattogram Road keeping Sheikh Hasina Sarani at-grade.

For three-arm intersection of Port connector with Dhaka Chittagong Road will also carry huge amount of traffic, where the Port Connector connecting logistic area and the port, will carry predominantly heavy commercial vehicles. To avoid any bottleneck for the traffic movement along both these roads a trumpet interchange is proposed at this location, keeping Port Connector road at-grade. The Dhaka – Chattogram Expressway will have the same treatment as stated earlier. The interchanges at these two locations will facilitate all directional movements without any hindrance.

The four-arm CP More intersection is a major intersection just inside the BSMSN area, the intersecting roads being Sheikh Hasina Avenue and Beri Bandh Road. Both these roads will carry significant amount of traffic, which will keep increasing with development of BSMSN. This intersection is to developed as regular 4 arm / rotary intersection initially and with increase of traffic to be upgraded

to a cloverleaf interchange facilitating all directional movements without any hindrance.

For the above intersections adequate land has to be reserved for development. It is expected that the traffic within BSMSN can be easily controlled by at-grade intersections. However, for any future need of grade separation at major intersections adequate ROW will be provided. The typical intersections types will be 3-arm / 4-arm / rotary (**Annexure 4.1-4.4**).

#### 4.1.4 Cost Estimations for the Transportation Network

Based on the master plan the off-site transport infrastructure costs (+/-15%) have been estimated as per 2020. The cost of developing interchanges outside BSMSN area, a new airport and seaport has not been included in cost estimates. The total cost estimates and phase-wise estimates are shown in **Table 4-3 and Table 4-4**.

##### a. Off Site Transport Infrastructure

Table 4-3: Cost Estimations for Off- Site Transport Infrastructure

Description of Item	Quantity/Unit	Price Without Tax		Phase I Cost Breakdown (Years 1-5)		Phase II Cost Breakdown (Years 6-10)		Phase III Cost Breakdown (Years 11-15)	
		(In Million Taka)	(In Million USD)	(In Million Taka)	(In Million USD)	(In Million Taka)	(In Million USD)	(In Million Taka)	(In Million USD)
<b>Off-Site Infrastructure Costs</b>									
<b>Transport</b>									
<b>Highway Improvements</b>									
Upgrade of Highway	49 Km	14,700	173	-	-	14,700	173	-	-
New Highway Access to BSMSN Boundary	-	-	-	-	-	-	-	-	-
Other (Interchanges/ Intersections)	10 No.	14,000	165	2000	24	12,000	141	-	-
<b>Sub Total</b>		28,700	338	2,000	24	26,700	314	-	-
Engineering Fees (5%)		1435	16.9	100	1.2	1335	15.7	-	-
Contingency (15%)		4305	50.7	300	3.6	4005	47.1	-	-
Taxes (18%)		5166	60.84	360	4.32	4806	56.52	-	-
<b>Total</b>		39,606	466	2,760	33	36,846	433		
<b>Rail Station Expansion/Improvements</b>									
Upgraded Station subtotal	2 Stations	2,000	24	1,000	12	1000	12	-	-
Engineering Fees (5%)		100	1.2	50	0.6	50	0.6	-	-
Contingency (15%)		300	3.6	150	1.8	150	1.8	-	-
Taxes (18%)		360	4.32	180	2.16	180	2.16	-	-
<b>Total</b>		2,760	33	1,380	17	1,380	17	-	-

Description of Item	Quantity/Unit	Price Without Tax		Phase I Cost Breakdown (Years 1-5)		Phase II Cost Breakdown (Years 6-10)		Phase III Cost Breakdown (Years 11-15)	
		(In Million Taka)	(In Million USD)	(In Million Taka)	(In Million USD)	(In Million Taka)	(In Million USD)	(In Million Taka)	(In Million USD)
<b>Rail Extension/Light Rail Expansion</b>									
Bring Rail Spur from Main Line to BSMSN Boundary	20 Km	8,000	94	8,000	94	-	-	-	-
Construct Rail from BSMSN to Chattogram	46 Km	27,600	325	-	-	27,600	325	-	-
Construct Light Rapid Transit from BSMSN to Chattogram	66 Km	52,800	621	-	-	26,400	311	26,400	311
<b>Sub Total</b>	132 Km	88,400	1,040	8,000	94	54,000	635	26,400	311
Engineering Fees (5%)		4420	52	400	4.7	2700	31.75	1320	15.55
Contingency (15%)		13260	156	1200	14.1	8100	95.25	3960	46.65
Taxes (18%)		15912	187.2	1440	16.92	9720	114.3	4752	55.98
<b>Total</b>		121,992	1,435	11,040	130	74,520	876	36,432	429
<b>Road Network Improvements from Highway to BSMSN Boundaries</b>									
Construct Road (40m)	48 Km	31,150	366	5,525	65	17,925	211	7,700	91
Construct Road (30m)	47.5 Km	19,150	225	12,200	144	6,950	82	-	-
Construct Road (20)	49 Kms	11,400	134	11,400	134	-	-	-	-
Sub Total	144.5 Km	61,700	726	29,125	343	24,875	293	7,700	91
Engineering Fees (5%)		3085	36.3	1456.25	17.15	1243.75	14.65	385	4.55
Contingency (15%)		9255	108.9	4368.75	51.45	3731.25	43.95	1155	13.65
Taxes (18%)		11106	130.68	5242.5	61.74	4477.5	52.74	1386	16.38
<b>Total</b>		85,146	1,002	40,193	473	34,328	404	10,626	126



## b. On Site Transport Infrastructure

Table 4-4: Cost Estimation of On Site Transport Infrastructure

Description of Item	Quantity/Unit	Price Without Tax		Phase I Cost Breakdown (Years 1-5)		Phase II Cost Breakdown (Years 6-10)		Phase III Cost Breakdown (Years 11-15)	
		(In Million Taka)	(In Million USD)	(In Million Taka)	(In Million USD)	(In Million Taka)	(In Million USD)	(In Million Taka)	(In Million USD)
<b>On-Site Infrastructure Costs</b>									
<b>Earthworks</b>									
Cut and Fill (cum)	297,343,774	1,414,014	16,635	424,204	4,991	565,606	6,654	424,204	4,991
<b>Embankment (cum)</b>	960,000	4560	54	3,192	38	1,368	16	0	0
Sub Total		<b>1418574</b>	<b>16689.11</b>	<b>427396.3</b>	<b>5028.192</b>	<b>566973.7</b>	<b>6670.279</b>	<b>424204.3</b>	<b>4990.639</b>
Engineering Fees (5%)		63336.6	745.15	19092.2	224.6	25311.85	297.8	18932.6	222.75
Contingency (15%)		190009.8	2235.45	57276.6	673.8	75935.55	893.4	56797.8	668.25
Taxes (18%)		228011.8	2682.54	68731.92	808.56	91122.66	1072.08	68157.36	801.9
Total		<b>1,957,633</b>	<b>23,031</b>	<b>589,807</b>	<b>6,939</b>	<b>782,424</b>	<b>9,205</b>	<b>585,402</b>	<b>6,887</b>
<b>Road Network</b>									
Road (100m)	59 Km	38,700	455	20,124	237	18,576	219	-	-
Road (60m)	29 Km	17,400	205	8,700	102	0	0	8,700	102
Road (40m)	55 Km	19,250	226	10,588	125	4,620	54	4,043	48
Road (30m)	62 Km	24,800	292	4,464	53	15,128	178	5,208	61
Road (20m)	235 Km	47,000	553	8,460	100	28,670	337	9,870	116
Sub Total	440 Km	147,150	1,731	52,336	616	66,994	788	27,821	327
Engineering Fees (5%)		7357.5	86.55	2616.8	30.8	3349.7	39.4	1391.05	16.35
Contingency (15%)		22072.5	259.65	7850.4	92.4	10049.1	118.2	4173.15	49.05
Taxes (18%)		26487	311.58	9420.48	110.88	12058.92	141.84	5007.78	58.86
<b>Total</b>		<b>203,067</b>	<b>2,389</b>	<b>72,224</b>	<b>850</b>	<b>92,452</b>	<b>1,087</b>	<b>38,393</b>	<b>451</b>



## 4.2 Power Networks within BSMSN

### 4.2.1 Overview

The 20-Year Power Infrastructure Master Plan for BSMSN is an overview of both the current and proposed state of power plus the necessary interventions required to support all types of land uses and activities within BSMSN.

### 4.2.2 Electricity Demand Assessment

#### a. Electricity Demand

The following electricity demand has been determined for the industrial precincts within BSMSN by using a data analysis method for clustering daily load requirements in industrial zone environments, classifying days in different groups with recognizable load patterns, and identifying meaningful characteristics for a proximity output.

Additionally, the electric power infrastructure for the remaining precincts within BSMSN depends on plot size, land use and building density (residential, commercial, institutional etc.). There electrical power demand is determined by kW/km<sup>2</sup> or kW/Acre.

#### b. Demand Assessment

Without an actual power design, the power demand of BSMSN is assessed and estimated by the careful application of kVA/Area rules.

Table 4-5: Demand Assessment of Electricity for BSMSN

Precinct	Area in Acres	kVA/Acre	Demand KVA		Demand Factor	Max. Demand (MW)
			KVA	KW		
A	4606.57	182	958439.30	862595.37	0.6	517.56
B	1682.91	182	323930.88	291537.79	0.7	204.08
C	837.35	182	148202.60	133382.34	0.7	93.37
D	1778.59	182	367710.98	330939.88	0.6	198.56
E	880.68	182	159082.56	143174.30	0.7	100.22
F	10043.12	182	1836875.04	1653187.54	0.8	1322.55
G	1802.29	121	217591.88	195832.69	0.7	137.08
H	1778.75	121	213014.45	191713.01	0.7	134.20
I	3956.35	182	720055.70	648050.13	0.8	518.44
J	6030.42	-	0.00	0.00	0	0.00
K	350.89	100	35089.00	31580.10	0.7	22.11
L	56.85	-	0.00	0.00	0	0.00
<b>Total</b>	<b>33804.76</b>					<b>3248.17</b>

#### c. Long-Term Electricity Demand Forecast

Demand forecasting is vitally important for the reliable and economic operation of power systems. A long-term electricity demand forecast on the transmission network from the final electricity consumption, the forecast of dispersed generation in the distribution network and losses within transmission and distribution network are necessary. In projecting electrical demand on high voltage systems an annual load

growth of around 5% is considered.

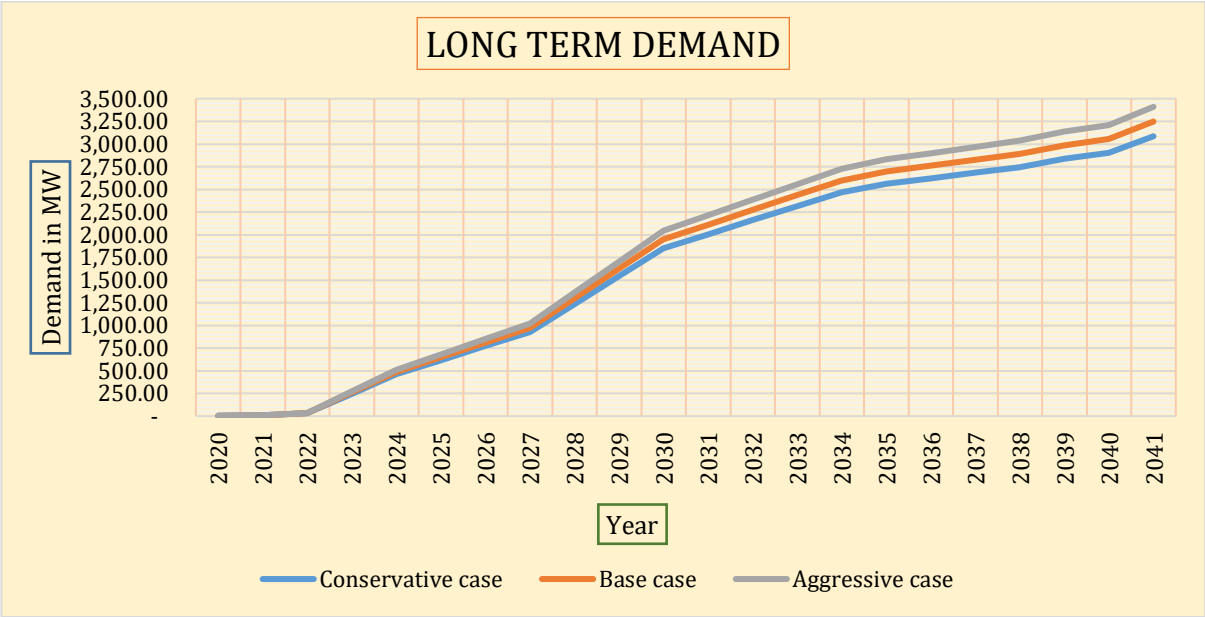

Figure 4-9: Long Term Demand

d. Peak Load Forecasts

Electricity demand and peak load development is one of the main drivers for transmission network planning. For the purpose of the 20-year development plan, an electricity demand forecast has been made by using the internationally established models for long-term electricity demand assessment; the future electricity needs are assessed at the level of final consumption and separately according to energy sources and the sectors of industry, traffic and other consumption. This presents a complex process, which is subject to a certain level of insecurity. All of the input data for the model assessments were evaluated based on the current state and the expected development of not only BSMSN, but also country’s need for its people and economy.

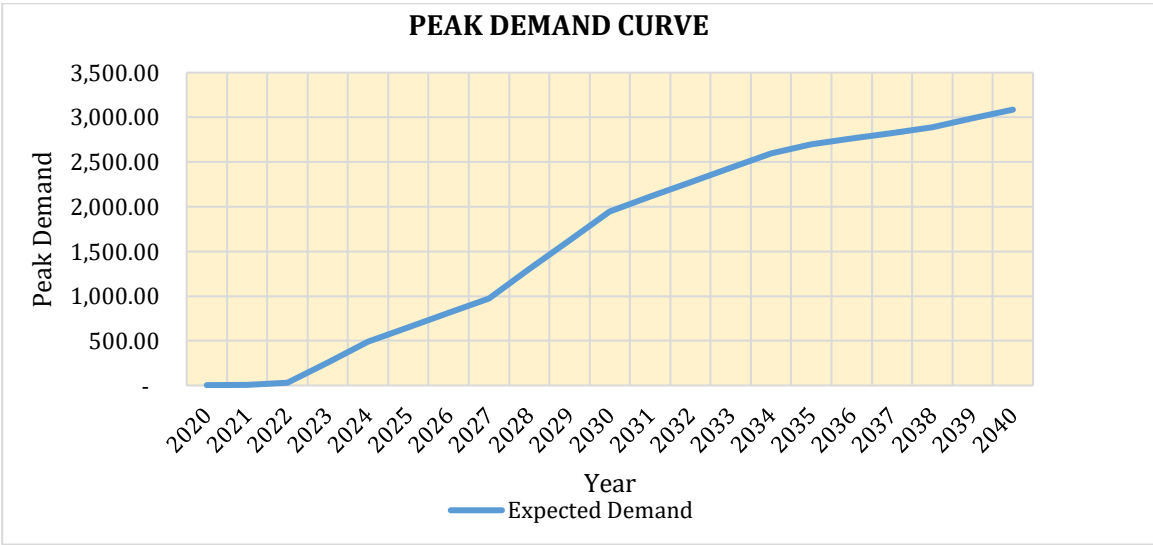

Figure 4-10: Peak Demand Curve

### 4.2.3 Source of Power

#### a. Power Generation

The Government of Bangladesh formulated Power System Master Plan 2016, which has estimated peak demand to reach 13,300 MW by 2020 and 19,900 MW by 2025 respectively. Therefore, to meet annual demand growth of about 13% during 2018–2020 and 10% during 2020–2030, about 25,000 MW of new generating capacity is required during 2018–2030.

Table 4-6: De-Rated Capacity of Power Plants as of May 2020

Fuel Type	Capacity (Unit)	Total (%)
Coal	444.00 MW	2.32 %
Gas	10,261.00 MW	53.7 %
HFO	5,206.00 MW	27.25 %
HSD	1,771.00 MW	9.27 %
Hydro	230.00 MW	1.2 %
Imported	1,160.00 MW	6.07 %
Solar	35.00 MW	0.18 %
<b>Total</b>	<b>19,107 MW</b>	<b>99 %</b>
	<b>20,383 MW</b>	<b>100 %</b>

\*\* Source: BPDB and NLDC

Total Generation capacity of Bangladesh up to May 2020 is 19107 MW, most of the generating units are directly connected to the Nation Grid. The government set a target to reach 24,000 MW by 2021, 40,000 MW by 2030, and 60,000 MW by 2041 including 10% of energy from renewable resources.

#### b. System Generation and Demand Scenario

Presently in the power system, electricity demand is less than installed generation capacity. The surplus or available electricity of the power system could meet the demand of the growing industrial sector in different economic zone. The power generation and demand scenario of the network is shown the table.

Table 4-7: System Generation and Demand Scenario

Generating Capacity (MW)	Demand (MW)		Balance Generation {MW}
	Day Peak	Evening Peak	
20,383	10,500	12,500	7,883

\*\* Source: NLDC, PGCB

#### c. On-Site Generation

Economic Zones cannot rely solely on the national grid for power. To be successful, a zone requires clean, consistent, and stable access to power and back-up power in cases of emergency. For tenants/residents of BSMSN, they will receive high quality power from a variety of sources. As such, a percentage of total demand may be met by on-site generation facilities, which use large natural gas turbines (CCPT/CCPP) that have capacities of several hundred megawatts. Smaller on-site generation systems, however, can be installed at delicate basic facilities, such as schools, hospitals and hotels (Please see **Table 4-8**).

In the present scenario, BSMSN may take 2,000 MW (without contingency) from the grid network against the demand of 3,248 MW through an existing, dedicated 400 kV transmission linked with the grid system. For reliable power and to meet the demand, generating units around the capacity of 1500 MW should be planned; onsite as well as more HV links should be developed to connect the zone HV network to grid system.

**d. Fuel Diversification and the Renewal of Source**

Power plants within BSMSN are perfect for the use of liquefied petroleum gas (LPG), natural gas, and/or liquefied natural gas (LNG). In some cases, in areas where natural gas will be available in the future, as an alternative option, exploring LPG as a ‘bridge’ fuel or an interim strategy until LNG infrastructure can be built over the longer term. Besides that aim to reduce the industry sector’s increasing demand for fossil fuels and the related CO2 emissions, a provision of renewable also be planned to install in the form of floating, rooftop and panel along the inner slop of the dike. There might be some potential of off shore wind turbines too.

Renewable energy source will be the best option for minimizing pollution, increasing economy, energy security. Clean energy development is a fundamental requirement for addressing climate change and mankind’s sustainable development as well as to maintain environmental sanctity of this world class industrial city.

In the table existing and planned on-site generation source for the mega economic zone with time line for future references.

*Table 4-8: Expected On-Site Generation*

Plants and Utilities	Phase I (MW)	Phase II (MW)	Phase III (MW)	Total (MW)
<b>Power Hub A, Precinct F (Zone 5)</b>				
IPP or Others	250	300	250	800
Renewable Energy Source	100		50	150
<b>Power Hub B, Precinct I (Zone 25)</b>				
IPP or Others		250	300	550
Renewable		50	50	100
<b>Total</b>	350	600	650	1600

System providers should plan the network at BSMSN in the manner some to be installed to satisfy and frequency and voltage control for maintain the quality of power and Black Start capability in extreme power outage. In each Variable Renewable Energy (VRE) generating unit is capable to generate maximum power output, depending on the availability of the primary resource, within the frequency range of 49.5 to 50.5 Hz. Generators and VRE unit shall be connected after facing a series of assigned tests.

**4.2.4 Transmission and Distribution Network**

The role of the transmission network is the reach the electricity from generation sources to different end user connected to the distribution network or directly to industries, and for the exchange of electricity with transmission grid network. The high-voltage transmission network consists of three voltage levels, namely those of 400, 230 and 132 kV levels.

To provide reliable power supply to BSMSN, transmission utilities already have been extended to the grid network by constructing a 7 km dedicated 400 kV overhead line (OHL), presently powered by 230 kV voltage and 230/33 kV substation from at site. In infrastructure planning more links in 400 kV and 230 kV voltage level may be considered with national grid network to enhance the power supply reliability.

In internal electrical infrastructure, as primary transmission, 230 kV network may be suitable for bulk load transmission to load centers for minimize losses, avoid congestions, and meet the future demand. The 132 kV voltage level may be considered as secondary transmission in radial/loop mode. The primary and secondary distribution network plan based on 33 kV and 11 kV respectively in mainly loop or radial mode

in any special case and at consumer end.

A 230/33kV Substation having capacity of 2 x 120/140 MVA (+ Future: 2x 120/140 MVA) has been commissioned on 20th May, 2020 feeding through a 400 kV architecture transmission line for Reliable Power Supply in economic zone. The substation is for 400 /230/33kV substation, rest 400/230kV substation section with 2x1000 MVA capacity will be commissioned by August 2022. The present power supply capacity through Mirsarai-BSRM 230kV Double circuit line is around 1100 MW (See Figure 4-11) (conductor: Twin ACCC, 3000 Amp).

Currently, power is mainly supplied through existing Baroirhat-Hathazari 132 kV double circuit line link from Baroirhat and Sitakundu substations. The distribution utility of PBS is supplying power through 33 kV feeder at BSMSN. The link will be strengthened in near future by making LILO at Korerhat and Fatikchari having capacity of 120 MW (ACSR Finch, 630 Amp).



Figure 4-11: HV Electrical Installation Around BSMSN

There are two 33 kV source lines with 477 sq mm conductor getting power from Baroirhat 132/33 kV grid substation. One 2x20/28 MVA substation has already been established by BSRM. Three substations are under construction, having capacity of 2x10/14 MVA, 2x20/28 MVA and 2x20/28 MVA.

Several distribution lines emanate from each distribution substation as overhead or underground lines. Distribution lines distribute the energy along streets and alleys.

Location of each utility installation point has been selected as per the prescribed guidelines mentioned in Section 3.1 of Chapter 3 of the BSMSN Master plan Report.

#### a. Primary Network

A network of transmission system has been created so that power generated at one station may be fed to grid system and may be distributed over large areas and number of users. The transmission and distribution system comprises a network of three-phase circuits with transforming and or switching substations at the various junctions.

The technical specifications cover detailed survey of site including route alignment based on the intermediate GPS readings and tentative route alignment finalized, profiling, tower spotting, optimization of locations, check survey, contouring, and soil investigation for the transmission lines / part of the

transmission lines covered under this specification.

The investigation and survey arrangement to be conducted to measure the soil resistivity along the route and to collect the data regarding change of course of rivers, major natural streams and canals, etc.

The best available sources shall furnish complete hydrological details on the routes including maximum velocity discharge, highest flood level (H.F.L), scour depth etc. of the concerned rivers, major streams and canals

An arterial transmission network is a sophisticated installation, which can coordinate and support the delivery of electrical power to the load i.e, industries and other facilities in different Precincts, which have very concentrated bulk load. And an arterial transmission network, as a large high-capital installation, inevitably attracts and funds a high level of technical and commercial attention to its planning, use and maintenance. This level of attention is crucial for an infrastructure network that needs to be secure, reliable, economical, and rapidly adaptable to changing demands and economic circumstances. These are the consideration of selection of voltage level, type of lines, selection of conductor or underground cable as the transmission backbone for electrical infrastructure of BSMSN.

Investment in smarter energy infrastructure helps achieve a shared vision of a smart, secure, and increasingly clean energy system that works to the benefit of all customers. Reaching the full potential of a modernized energy grid requires ongoing investment.

Table 4-9: Length of Inter Connection Lines

Region	Line Voltage Level	No. of Circuits	Total Length in Km (Approximate)	Route Length in Km	Special Considerations
OFF-SITE	400 kV	Double	83	166	Overhead
	230 kV	Double	16	32	Overhead
ON-SITE	400 kV	Double	25	50	Overhead or U/G (Route-1)
		Double	40	80	Overhead or U/G (Route-2)
	230 kV	Double	14	28	Overhead or U/G; 0.7 km River Crossing
	230 kV	Double	100	200	Underground
	132 kV	Double	8	16	Underground

With an underground cable, the conductors are encased in insulated material and buried in a backfilled or trench of suitable depth and width. Whilst the number of cables, and the depth and width of the trench depends on the voltage that is required to be transmitted, the width of the trench can be substantial, where connected to an overhead line; an underground cable may also involve the siting of terminal supports and sealing end compounds above ground. These require their own siting appraisal, which should normally be undertaken in conjunction with the overhead line/underground cable routing.

**b. Primary Substations/Grid Substation (GSS)**

Substations in transmission level, are integrated by more than one inter-connection, so that power can flow freely over distances from the sources to the consumers. The transmission grid is often called the bulk power system. Typically, transmission lines operate at voltages above 132 kV. Transmission substations acts to transfer energy by transforming one transmission voltage level to another voltage level. In the site development planning, substations of different types and configurations may be designed in 400/230/132/33 kV, 230/132/33 kV, 230/132/33 kV, 230/33 kV and 132/33 kV depending on the quantum of load and industries under the substation (please see **Table 4-10**).

As per initial proposed transmission network configuration the following substation and transmission lines



are proposed focusing load center, bulk load consumer, network congestion, redundancy, expandability, plant factor etc.

Table 4-10: Location of Substations

Precinct	Type and Voltage levels	Number of Substations	Unit and Ultimate Capacity (MVA)
F, I	GIS; 400/230/33 kV	2	2x1000 + 1x1000+4x80/120
A, C, D, F	GIS; 230/33 kV	8	4 x 120/140 + 4x80/120
A, I	GIS; 132/33 kV	2	4 x 120/140

\* GIS-Gas Insulated System

\*\* Transformer MVA capacity and quantity may vary after conducting network study.

In BSMSN, 12 numbers of substations of different voltage levels have been proposed and locations of each substation has been selected as per the prescribed guidelines mentioned in Section 3.1 of Chapter 3 of BSMSN Master plan Report. BEZA management will keep the provision of land for substations of different voltage levels and corridor for overhead transmission line and cable line in required quantities and locations in the land use plan. The way of corridor of cable lines and right of way of overhead line shall also be accommodated in the road plan and site plan of the precincts. The utilities shall develop their electrical infrastructure over the development period on the land and roadways reserved for electrical lines. Location of substations and different power network of BSMSN has been shown in **Figure 4-13**.

**c. Single Line Diagram (SLD) Of Preliminary High Voltage (HV) Network**

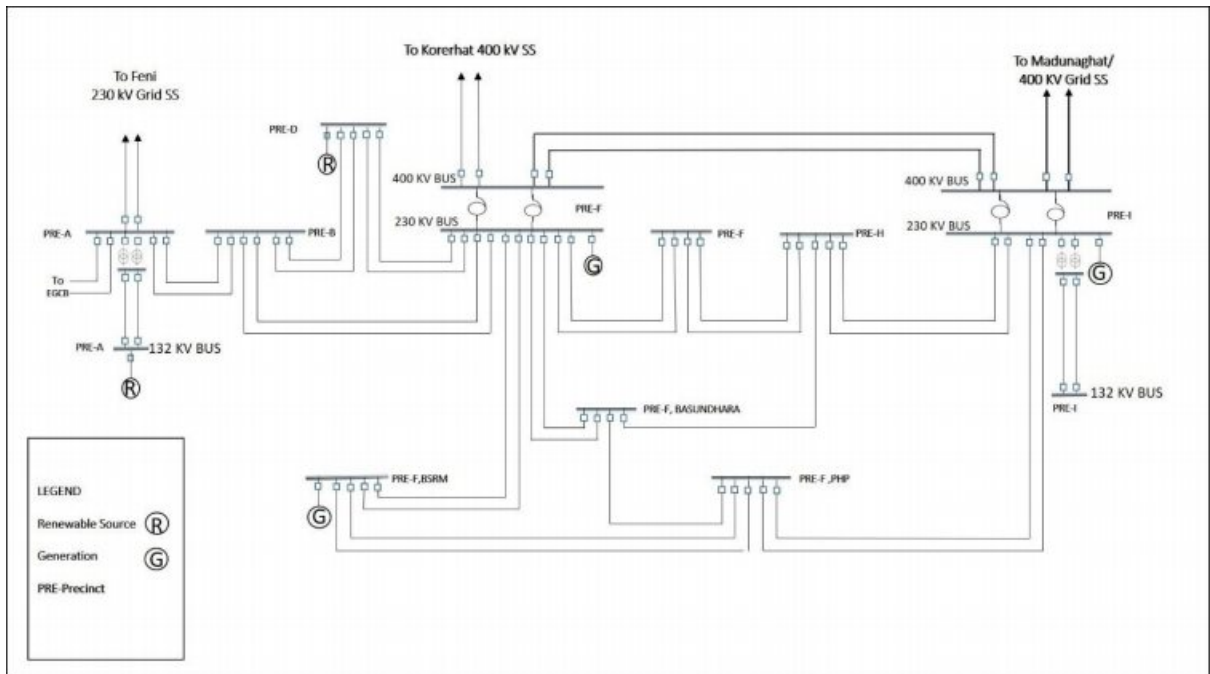

Figure 4-12: Single Line Diagram of High Voltage Network in BSMSN, Mirsharai, Feni and Sitakundo

Based on the demand forecast and load center, the following preliminary high voltage primary transmission network is outlined.

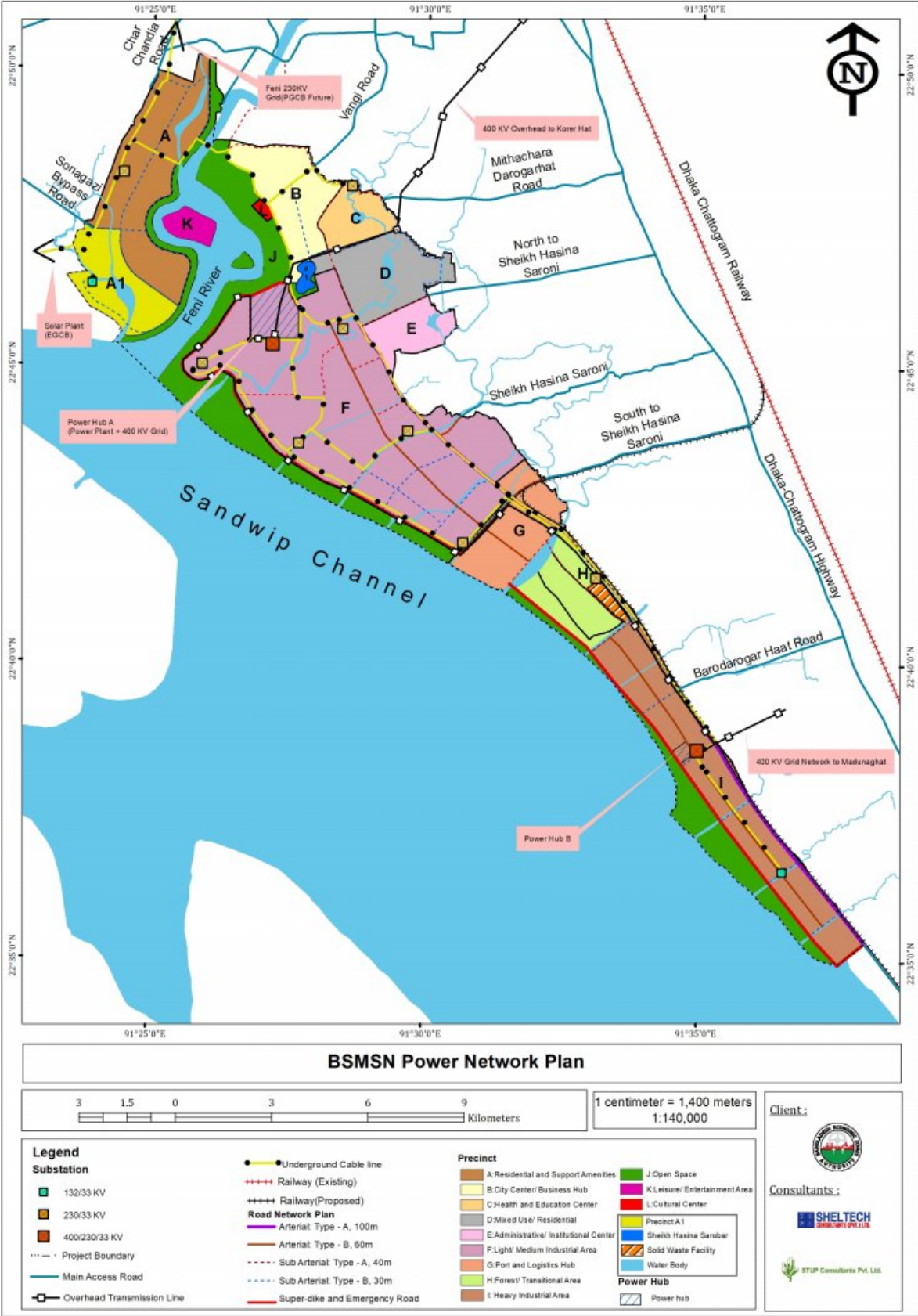

Figure 4-13: BSMSN Power Network Plan

**d. Land Required for Electrical Infrastructure**

The land location for the installation of electrical infrastructure should be chosen near the load centers inside respective Precincts within BSMSN. BEZA shall keep the required size of land at potential locations for power hubs, substations of different voltage levels, and transmission/distribution line routes/ corridors for overhead/underground lines for BSMSN. These have been shown in **Figure 4-13**.

The average land required (in acres) for different voltage levels, facilities and capacity is presented in **Table 4-11**.

*Table 4-11: Average Land Required for Different Voltage Levels*

<b>Power Plant (Acres/MW)</b>	Combined Cycle Power Plant (Duel Fuel)	10-12.5	
	Combined Cycle Gas Turbine (LNG)	10-15	
	SOLAR	3	
<b>Transmission (Acres)</b>	Substation Voltage Levels	Air Insulated Substaion	Gas Insulated Substaion
	400 /230/132/33 kV SS	90	60
	230/ 132/ 33 kV SS	10	5
	230/33 kV SS	7	3
	132/33 kV SS	5	2
<b>Distribution (Acres)</b>	33/11 kV SS	1.5	0.75
	33/11 kV SS and SCADA Control Center	3.5	2.5
	RMU HUB 33kV and 11 kV	0.03 and 0.05	

Right-of-Way, strip of land set aside for a safety corridor distance between the power line and nearby structures and vegetation and which is used by the Licensee to construct, maintain or repair a power line. Transmission Line Right-of-Way also aids to consider safety clearances and EMF exposure limits.

*Table 4-12: Right of Way and Corridor for Overhead Line and Underground Cable Line Respectively*

Voltage Levels		0.4 kV	11 kV	33 kV	132 kV	230 kV	400 kV
Overhead Line	Right of Way Width (m)	3	7	15	27	35	46
Underground Cable Line	Corridor Width (m)	0.3	0.6	1.5	2.5	3.2-3.5	7.5-7.7
	Minimum Depth of Burial (m)	0.6	0.8	1.0	1.2	1.4	1.8

The width of the corridor for different voltage levels is to be recorded effectively by developing a complete digital map in a suitable scale (1":1100') by using Global Information System (GIS) and Global Positioning System (GPS).

**e. Synchronization and Islanding**

The HV network in economic zones can be facilitated to operate in grid-connected or islanded mode. The Remedial Action Schemes (RAS) are usually applied to local grid part after a fault instance, and, accordingly, to the local grid transitions to an islanded (isolated) operation mode. RAS takes synchro phasor-measured real power of the lines between two grid parts.

In the grid-connected mode, frequency and voltage regulation is handled by the grid operator, NLDC. However, in an islanded operation, a local grid must be able to regulate internal frequency and voltage with a proper control mechanism in the network equipment's, generators (by proper droop setting).

The System operator shall operate the transmission system at BSMSN and other users of the transmission system shall operate their plant and/ or systems for the generation and distribution of electricity in so far as necessary to protect the security and quality of supply and safe operation of the Licensee's Transmission System under both normal and abnormal operating conditions.

The interconnection with the national grid is considered as the main and backup philosophy. On 400 kV level the main sources from grid are, namely, BSMSN to Korerhat and alternate source, namely, BSMSN to Madunaghat. For any emergency a link in 230 kV voltage level is also considered for source, namely, BSMSN to Feni.

**f. Secondary Network**

The best distribution system may consider, which is cost-effective and safe, supply adequate electric service to both present and future probable loads. Distribution of electricity involves the transfer of electrical energy from one electric substation to another electrical substation, like 230/33 KV S/S to 33/11 KV S/S and 33/11 KV S/S to 11/0.4 KV Distribution Transformer RMU or substation etc., through sub-transmission and distribution lines. These lines may be overhead lines or underground cables. Each of the two types has its benefits as well as demerits.

The distribution network supply electricity more than one source, ensuring reliable supply, through Ring Main Units (RMU) from 230/33 kV and 33/11 kV substation of located in the Precinct or nearby Precinct.

The Ring Main Units is one of best solution for underground cable distribution network at the load connection and junction points of a ring-type distribution network. 3/4-Way Compact Indoor Type Ring Main Unit are also suited for use in Compact secondary substations, Small industries, Hotels, office buildings, residential housing complex, shopping centers, business centers, hospitals, airports etc.

Table 4-13: Secondary Distribution Network

Precinct	Substation	Voltage and Type	Capacity (MVA) Each	Required RMU (approx.)
A	9	33/11KV GIS	4x20/28 3x 20/28	350
B, C	8			
D	5			
E	4			
F	22			
G	3			
H	2			
I	7			
J, L	0			
K	2			
<b>Total</b>	<b>62</b>			

\* Number of substation and RMU’s may vary after conducting a network study.

\*\* Transformer MVA capacity and quantity may vary after conducting network study.

The link between substations, substations to RMU or RMUs may be either overhead line or underground cable line. Underground line construction might be the least-cost approach in areas where overhead lines are susceptible to storms, such as cyclones, because of the high cost of replacing poles that fail prematurely. Under these conditions, the life-cycle cost of poles and their replacement might exceed the cost of underground construction. The links of 33 kV and 11 kV distribution network and estimated distances are:

Table 4-14: Estimated Distance of Links of 33 KV and 11 KV Network

Location	Line Voltage Level	No. Of Circuit	Total Length In Km (Approx.)	Route Length In Km	Special Considerations
OFF SITE	33 kV	Double	30	60	
ON SITE	33 kV	Double	125	250	U/G; 0.7 km Feni River Crossing

\*\* The exact length of the line and size of cable/conductors shall be finalize after necessary study/analysis and survey.

**g. Potential Development Activities and Time Line**

The goal of investment is ensuring cost-effective and timely implementation of priority electricity networks, with the goal of increasing security and reliability of supply, enhancing grid network connectivity and enabling electricity transport from source of energy and electricity end users.

*Table 4-15: Potential Development Activities and Time Line*

ACTIVITY	YEAR OF COMPLETION																					
	2020	2021	2022	2023	2024	2025	2026	2027	2028	2029	2030	2031	2032	2033	2034	2035	2036	2037	2038	2039	2040	2041
Power Plant (Duel Fuel-HFO)	■										■											
Power Plant (LNG/LPG)																						■
RES			■													■						■
400 kV TL construction ( off-site and on-site)											■											■
230 kV TL construction OHL/UGL ( off-site and on-site)		■				■										■						■
132 kV TL construction UGL																						
33 kV Distribution Line UGL		■				■						■										
11 kV Distribution Line UGL		■				■						■										
RMU 33 kV and 11 kV Installation		■				■						■										
400/230/33 kV Substation construction											■									■		
230/132/33 kV Substation construction																					■	
230/33 kV Substation construction		■				■										■				■		
132/33 kV Substation construction																					■	
33/11 kV Substation construction		■				■					■					■				■		■
Street Lighting and Security Lighting System	■				■							■									■	
SCADA and DMS system Installation ( phase 1 = Phase 2)																■						■



**h. Regulatory Documents and Standards**

The master plan addresses comply with the following statutory/technical regulations and international/local technical standards.

- Power System Master Plan 2016
- Electricity Grid Code 2018b
- Renewable Energy Policy of Bangladesh
- Bangladesh National Building Code (BNBC)
- Electrical Safety Codes of Practice and Regulation
- Fire Prevention and Extinction Rule- 1961
- Code of Practice for the Electricity (Wiring) Regulations – 2015
- Bangladesh Energy Regulatory Commission Act 2003
- Distribution Code
- Electricity Act 2018.

**4.2.5 Cost Estimation for Electrical Infrastructure**

**1. Major Fields of Cost Assessment**

Modern and smart electrical infrastructure within BSMSN is as follows:

<b>Major Fields Of Infrastructure Investment</b>	Power Generation	Gas Turbine Plants (Duel Fuel) Combined Cycle Power Plant (LNG) Renewable (Solar/Wind)
	Power Transmission	HV Transmission Line HV Substation Shunt Reactors Shunt Capacitor Banks
	Distribution	MV and LV Distribution Line MV and LV Substations Shunt Capacitor Banks Ring Main Unit (RMU) with Transformers Distribution SCADA and DMS Street and Security Lighting System
	Ancillary Systems	Frequency Measure, Voltage Compensation, Genset, Harmonic Suppressor, Spinning Reserve, Electric Vehicles Charging, Mobile Substation etc.
	Technical Assistance Consultant	Network Study

**i. Capital Investment Requirement**

In general, the proposed projects are limited to those largely dependent on the government sector investments, including those to be implemented by public enterprises. Most of the utilities development projects which can be implemented by private enterprises are not much focused in this master plan. Projects of power supply and ICT are thus limited to several key facilities development, assuming that

connection to the end users can be realized by private companies with tariff-based financing schemes.

Cost estimation for Key power and electrical infrastructure construction project by Phase in light of Master Plan guidelines.

Table 4-16 Cost Estimations for Power Network

Description of Item	Price Without Tax		Phase I Cost Breakdown		Phase II Cost Breakdown		Phase III Cost Breakdown	
	(In Million Taka)	(In Million USD)	(In Million Taka)	(In Million USD)	(In Million Taka)	(In Million USD)	(In Million Taka)	(In Million USD)
<b>OFF-SITE</b>								
Transmission	4359.5	51.2882	700	8.23529	750	8.82352	2909.5	34.2294
Engineering Fees (5%)	217.975	2.56441	35	0.41176	37.5	0.44117	145.475	1.71147
Contingency (15%)	653.925	7.69323	105	1.23529	112.5	1.32352	436.425	5.13441
Taxes (18%)	784.71	9.23188	126	1.48235	135	1.58823	523.71	6.16129
<b>Off Site Total</b>	<b>6016.11</b>	<b>70.7777</b>	<b>966</b>	<b>11.3647</b>	<b>1035</b>	<b>12.1764</b>	<b>4015.11</b>	<b>47.2365</b>
<b>ON-SITE</b>								
Generation	88659.5	1043.05	15069.9	177.292	20461.8	240.727	53127.9	625.034
Transmission	69493.7	817.57	14160	166.58	17936.6	211.018	37397	439.964
Distribution	39737.8	467.503	9301.3	109.427	11045.5	129.947	19391	228.129
SCADA and Communication Network	1370	16.1176	0	0	0	0	1370	16.1176
Ancillary Services and Lighting System	4902.5	57.6764	294.1	3.46	775.2	9.12	3833.2	45.0964
Technical Assistance	250	2.94117	250	2.94117	0	0	0	0
Sub Total	208773	2456.15	39775.3	467.936	50969.1	599.635	118028.	1388.57
Engineering Fees (5%)	10438.6	122.807	1988.76	23.3968	2548.45	29.9817	5901.43	69.4285
Contingency (15%)	31315.9	368.422	5966.29	70.1904	7645.36	89.9453	17704.2	208.285
Taxes (18%)	37579.1	442.107	7159.55	84.2285	9174.43	107.934	21245.1	249.942
<b>On-Site Total</b>	<b>288106</b>	<b>3389.48</b>	<b>54889.9</b>	<b>645.752</b>	<b>70337.3</b>	<b>827.497</b>	<b>162879.</b>	<b>1916.22</b>
<b>Grand Total</b>	<b>294122</b>	<b>3460.2</b>	<b>55855.</b>	<b>657.11</b>	<b>71372.</b>	<b>839.67</b>	<b>166894</b>	<b>1963.4</b>

Note: Excluding 0.4 kV distribution system.

To reach the set objectives in the period from now to 2041, the Master Plan anticipates that investments in the height of BDT 294122 million will be required. The realization of the planned investing will influence the reliability of the electricity supply and prices, the increased production of the national economy and the increasing of GDP.

### 4.3 Gas Network

#### 4.3.1 Overview

Petrobangla is the only energy company in Bangladesh. Its subsidiary, the Bangladesh Petroleum Exploration Company (BAPEX), is responsible for exploration of oil and gas. International oil companies must sell natural gas to Petrobangla at a government-determined price. They are also restricted to sell natural gas to customers directly. Gas Transmission Company Limited (GTCL) is responsible for



transmission of natural gas all over Bangladesh. The 24 inches Bakhrabad-Chattoogram Transmission line of GTCL passes along the Dhaka-Chattoogram Highway, about 10 km from the site.

Gas distribution to the consumers is the responsibility of six regional distribution companies. BSMSN falls under the jurisdiction of Karnaphuli Gas Distribution Company Limited (KGDCL). At present, there is no gas connection network at the site or in its immediate surroundings. The local households use LPG (Liquefied petroleum gas) cylinders and fire wood for cooking purposes.

KGDCL has developed a project to establish a dedicated gas network to the BSMSN. At present, 200 mmcf/d gas will be distributed to the site. For this, the company has planned a gas pipeline network within the site, with other supporting infrastructure. It has plans to also build a Town Board Station (TBS) at Barotakia (Mirsarai) and connect the gas network with the GTCL transmission network via the Sheikh Hasina Saroni.

#### a. Natural Gas Overview

Natural gas has significant importance in the economic development of Bangladesh. It is one of the major sources of energy in Bangladesh that is being widely used as raw fuel to produce bulk amount of electricity, garment product, paper, chemical, food, engineering product etc. However, due to the scarcity of natural gas reserve in different gas field in Bangladesh, the government has greatly emphasized on efficient use of gas as well as mixing up other alternative fuel to natural gas pipeline such as LNG (liquefied Natural Gas). At present almost 1000 MMSCFD LNG gas, which is being imported from Qatar and stationed in Cox's Bazar FSRU (Floating Station Re-gasification Unit), is being injected continuously to natural gas transmission line to meet up the ever increasing demand of booming industrial sector. Apart from natural gas a limited amount of coal, coke, diesel, petroleum, octane etc. are used as a fuel. Nuclear power is in the initial phase as government is implementing the Ruppur Nuclear Power plant, which is expected to produce electricity in 2025.

As Bangladesh is highly dependent on indigenous natural gas for its primary energy supply as well for power generation, natural gas resources provide approximately 72% of Bangladesh's commercial energy supply and imported oil provides the balance.

Gas transmission and distribution system are gas pipeline system and associated facilities designed for gas supply to consumers. Gas transmission and distribution system is a link between gas fields and gas consumers. In Bangladesh, there are 21 operating gas fields producing nearly 2700 MMSCFD gas. During the connection, customers must follow the rules and regulation for transmission and distribution of natural gas.

There are 13 companies operating under Petrobangla, dealing in oil and gas exploration (mainly BAPEX, production (BAPEX, BGFCL, SGFL), transmission (GTCL, TGTDCL, JGTDCL) distribution (TGTDCL, BGDCL, JGTDCL, PGCL, KGDCL, SGCL), conversion (RPGCL) as well as development and marketing of coal and granite (BCMCL, MGMCL).

#### b. Efficient Use of Natural Gas

There are two critical aspects of proper natural gas use. These are as follows:

- Effective gas management at the consumers end
- Effective gas supply network, engineering design, operation, maintenance and protection.



### 4.3.2 Gas Demand Projections

The demand for gas is determined based on a unit consumption per day per unit of area for various categories of industries. **Table 4-17** illustrates the gas demand for different industrial categories in BSMSN until 2040. A more detailed overview is shown in **Annexure 4.5**.

*Table 4-17 Gas Demand for Different Industrial Categories*

Industrial Category	Area in Hectares	Area in Acres	Gas Demand m3/day/acre	Total Gas Demand m3/day	Total Gas Demand in mscfd	Remarks
<b>Chemical Hub</b>						
Chemical	34.52	85.31	99	4222.64	0.15	Considering 50% manufacturing Area
Chemical, Foam	8.34	20.61	99	1020.37	0.04	Considering 50% manufacturing Area
Chemical, Paints	20.35	50.28	3,700.00	93014.45	3.28	Considering 50% manufacturing Area
Garments	4.11	10.15	3,642.17	18482.21	0.65	Considering 50% manufacturing Area
Sub Total	67.32	166.35		116739.66	4.12	
<b>Heavy Industrial</b>						
Sub Total	1,565.56	3,868.50	606.32	938221.25	33.13	Considering 40% manufacturing Area
<b>Light/ Medium Industrial</b>						
Auto Mobile, Mango	48.16	119.01		0.00	14.42	Getting Demand from Investors
Bashundhara	228.67	565.03		0.00	79.79	Getting Demand from Investors
Chemical	4.59	11.33	99	504.89	0.02	Considering 50% manufacturing Area
Food and Beverage	18.22	45.03	404.69	9111.93	0.32	Considering 50% manufacturing Area
Garments	383.66	948.02	3,642.17	1726421.55	60.96	Considering 50% manufacturing Area
Garments Accessories	2.03	5.02	99	248.36	0.01	Considering 50% manufacturing Area
Light and Medium Industrial Area	2,620.72	6,475.80	226.05	585541.58	20.68	Considering 40% manufacturing Area
Light Engineering	4.19	10.35	95	491.48	0.02	Considering 50% manufacturing Area
LNG Petro Chemical	22.71	56.11	0	0.00	0.00	Considering 50% manufacturing Area
Pharmaceuticals	12.22	30.19	99.96	1508.81	0.05	Considering 50% manufacturing Area
Power Plant, B-R Power	6.49	16.04		0.00	40.25	Getting Demand from Investors

Industrial Category	Area in Hectares	Area in Acres	Gas Demand m3/day/acre	Total Gas Demand m3/day	Total Gas Demand in mmmcf/d	Remarks
<b>Chemical Hub</b>						
Power Plant, B-R Power Extension	20.23	50.00			107.75	Getting Demand from Investors
Power Plant, BSRM Power	7.87	19.44		0.00	52.97	Getting Demand from Investors
Steel Industry, BSRM	80.92	199.96		0.00	2.06	Getting Demand from Investors
Steel Industry, PHP	246.76	609.76		0.00	121.70	Getting Demand from Investors
Steel Product	43.27	106.91	300	16036.52	0.57	Considering 50% manufacturing Area
Textile	277.25	685.08	3,642.17	1247592.86	44.05	Considering 50% manufacturing Area
Utility	13.35	33.00	0	0.00	0.00	
Sub Total	4,041.31	9,986.08		3587457.98	545.61	
<b>Port/ Logistics/ Light/ Medium Industrial</b>						
Sub Total	236.67	584.81	226.05	33049.06	1.17	Considering 25% manufacturing Area. As per the precinct plan, part of this logistic area will be used for light and medium industry
<b>Grand Total</b>	<b>5,910.86</b>	<b>14,605.74</b>		<b>0.00</b>	<b>584.03</b>	

### 4.3.3 Gas Supply Components

#### a. Engineering Design, Operation, Maintenance and Protection of a Gas Line

Although often dependent on the Gas Company, the following is an example of the steps involved in the design of a system.

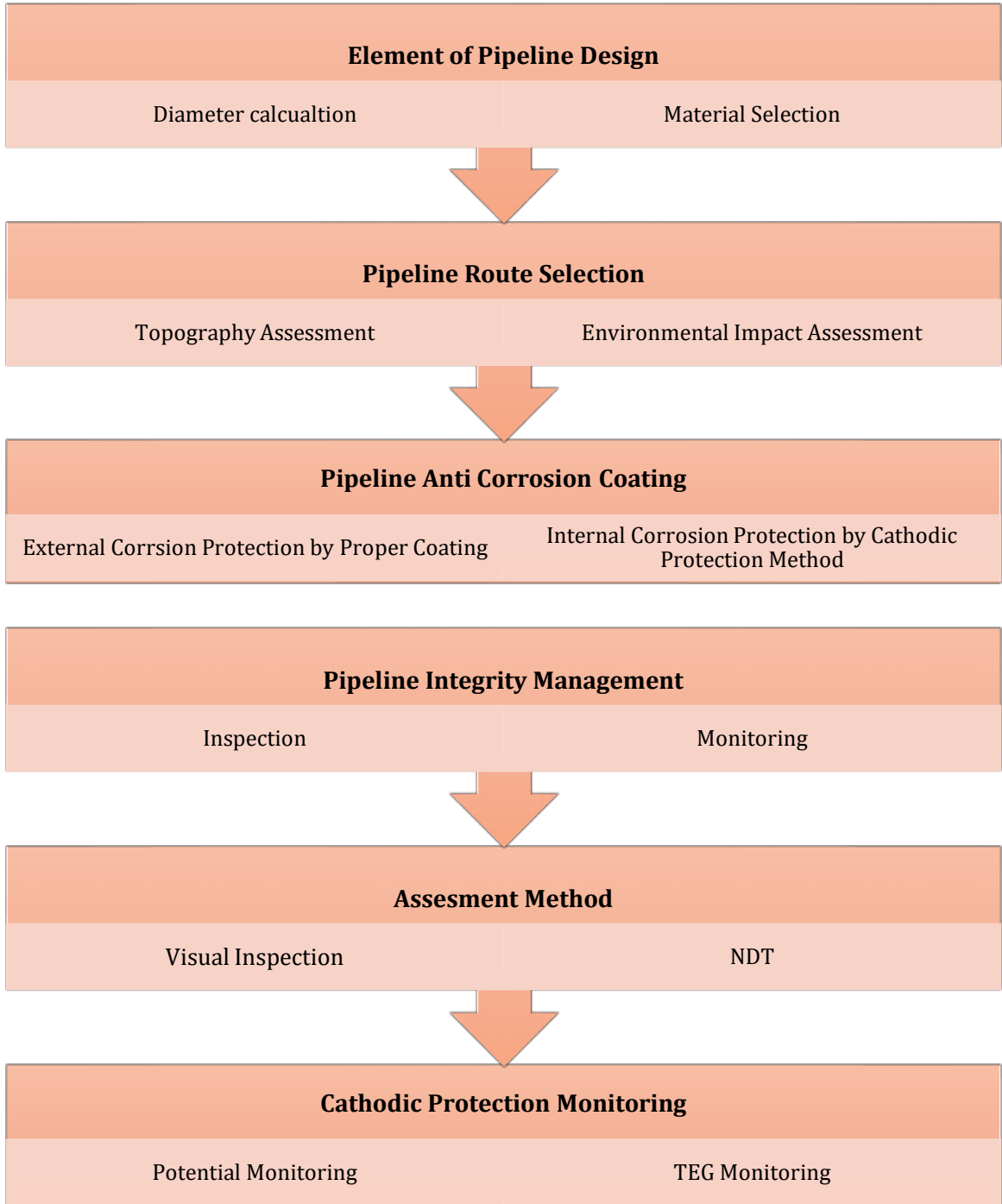

### b. Rules and Regulation of Transmission and Distribution

Gas transmission and distribution system is a gas pipeline system and associated facilities designed for gas supply to consumers. A gas transmission system is a link between gas fields and gas consumers. Transmission and distribution of natural gas is not an easy task because several law, rules and regulation are needed to flow during transmission or distribution of natural gas. The following existing laws are most common in Bangladesh.

- Carbide Rules 2003
- Explosive Act 1884
- Gas Cylinder Rules 1991
- Natural Gas Safety Rules 1991
- Natural Gas Safety Rules 2003
- Petroleum Rules 1937
- CNG Rules 2005
- LPG Rules 2004

### c. Design Guidelines

The following are some basic design guidelines for the Gas Network:

- Use uniform or proper material selection, otherwise inhomogeneous material may cause pipe corrosion
- Use proper materials for bend and weld joints, otherwise it may cause pitting,/hydrogen corrosion
- Proper selection of ROW and filling material is important, otherwise may cause external corrosion
- Proper gas velocity setting is required, otherwise, may cause erosion cracking.

### d. Pipeline Materials, Design and Construction

During transmission or distribution of natural gas, the company need to flow the following steps.

#### **General Properties of Pipe Line Constructing Materials**

All pipelines and accessories must be selected as per API and ASMI standards. The pipe materials must have the following properties:

- The property of pipe materials cannot change with temperature
- The pipe materials cannot attain any chemical reaction with transferring gas or liquid

### Pipe Standardization

- The pipes may be made of steel, plastics or other materials
- The Pipes must meet API code

### Pipe Design

- The design parameters for steel pipe will be determined in accordance with the following equation:

$$P = 2St/D \times F \times E \times T$$

Where:

P = Internal Design Pressure, psig; S = Specified minimum yield strength, psi; D = Nominal outside diameter of the pipe, inches; t = Specified wall thickness of the pipe, inches; F = Design Factor determined according to 49 CFR 192.111; E = Seam joint factor determined according to 49 CFR 192.113; T = Temperature factor determined according to 49 CFR 192.115

However, for short distance low pressure gas line ( up to 10 Bar) mass continuity equation is used as follow:

$Q = (DXDXPXV)/0.75$ , where Q= standard cubic feet, D=Diameter in inch, P= Operating Pressure in Psia, V= Gas velocity (20 m/sec)

- The design parameters for Plastic pipe will be determined in accordance with the following equation  

$$P = 2St/ (D-t) \times 0.32$$

Where:

P = Internal Design Pressure, psig; S = Specified minimum yield strength, psi; D = Nominal outside diameter of the pipe, inches; t = Specified wall thickness of the pipe, inches

### Pigging System

- All 300-psig transmissions or the main line must have a pigging system
- For offshore pipelines, they must have two pigging platforms

### Valve Attachment

- In populated areas, within 10 km and other place 30 km
- Must have control ability easily
- Should be protected from any hazards

### e. Compressor Station Design

- Compressor stations constructed with anti-firing materials
- Compressor stations must be 20 m away from building

The positioning of valve, meters, and electrical circuits within the compressor station must follow:

- The Petroleum Rules 1937 (Rule 105)

- High maintenance capability

**f. Customer Station Design (CMS)**

- CMS stations must be constructed with anti-firing materials
- CMS station must be away from buildings

The positioning of valves, meters, and electrical circuits within the CMS station must follow:

- Petroleum Rules 1937 (Rule 105)
- High maintenance capability

**g. Path Design for the Pipelines (ROW)**

- Must be safe for the environment
- Before ROW, selection must attain a survey (both case)
- Must maintain minimum land acquisition as in Table 4-18

*Table 4-18: Minimum Land Acquisition Required for a Pipeline*

Pipe Size	150 psig-300 psig	>300 psig
<20 inches	2 m	3 m
>20 inches	3 m	3.5 m

- Plastics pipes must fill up by soil or other materials
- If distance rule is not adhered to, ability to take action according to rules from the Petroleum Act, 1934 (Section 23)

**h. Minimum Depth**

The pipeline must place below surface area according the table given:

*Table 4-19: Minimum Depth of Pipeline for BSMSN*

External Diameter of Pipe (cm)	Maximum Allowable Pressure (kg/cm <sup>2</sup> )				
	7	7-9	10-15	16-24	>25
	Depth (cm)				
<20	90	95	100	105	110
21-40	91	96	101	106	112
41-60	92	97	102	107	115
61-80	93	98	103	108	120
>80	94	99	104	109	125



**i. Pipeline Define Signs**

- Putting of a red sign is required, which defines the pipeline (not over 500 m in general places) and not over 200 m in a densely populated area.
- Must put sign in a road, pond, river or railroad
- In offshore cases, take extra care of pipe

**j. Minimum Distance Between Two Pipes**

- Minimum 0.5 m distance between two cross over pipelines
- Minimum 1.5 m distance between two parallel pipelines
- Avoid drainage lines
- Maximum depth of transmission and distribution line is not over 2 m.

**k. Pipeline Welding**

- Experienced persons are required for pipe welding
- The welder must have experienced within the last 6 months
- API standard rules must be followed (Rule 1104)
- Welding pipes must have sustainability above the transmission pressure

**l. Pipeline Testing**

- When transmission pressure is above 20.5 kg/cm<sup>2</sup>, for testing, need to use water and need to maintain pressure for more than 24 hours.
- When the transmission pressure is below 20.5 kg/cm<sup>2</sup>, for testing water, gas or air may be used and need to maintain pressure for more than 24 hours
- The testing pressure is 1.25X for transmission pressure besides populated areas
- The testing pressure is 1.5X for transmission pressure within populated areas

**m. Pipeline Corrosion Removal**

- Use environmentally friendly coating to remove corrosion
- Examine the coating every three years
- Use a cathode protection system within one year (Based on ANSI code 01-72)
- Check power system within every 75 days

- Every pipeline must connect to a testy rod

**n. Pipeline Management**

- After 25 years of construction, test the pipeline every 5 years
- b. Always transmit gas within the acceptable limits

**o. Distribution Rules**

- Do not store gas or condensate without a storage license conforming to Pressure Vessel Rules-1995
- Condensate storage and transmission based on Petroleum Rules, 1937
- Acceptable distribution pressure is 0.1 kg/cm<sup>2</sup> -4.00 kg/cm<sup>2</sup>
- Distribution pipe diameters cannot be more than 5 cm
- Always use safety valves/ relief valves for safety.

**4.3.4 Gas Supply Network**

The 24 inches Bakhrabad-Chattogram Transmission line of GTCL passes along the Dhaka-Chattogram Highway, about 10 km from the site. **Figure 4-14** illustrates the location of each utility installation point per the prescribed guidelines mentioned in Section 3.1 of Chapter 3.

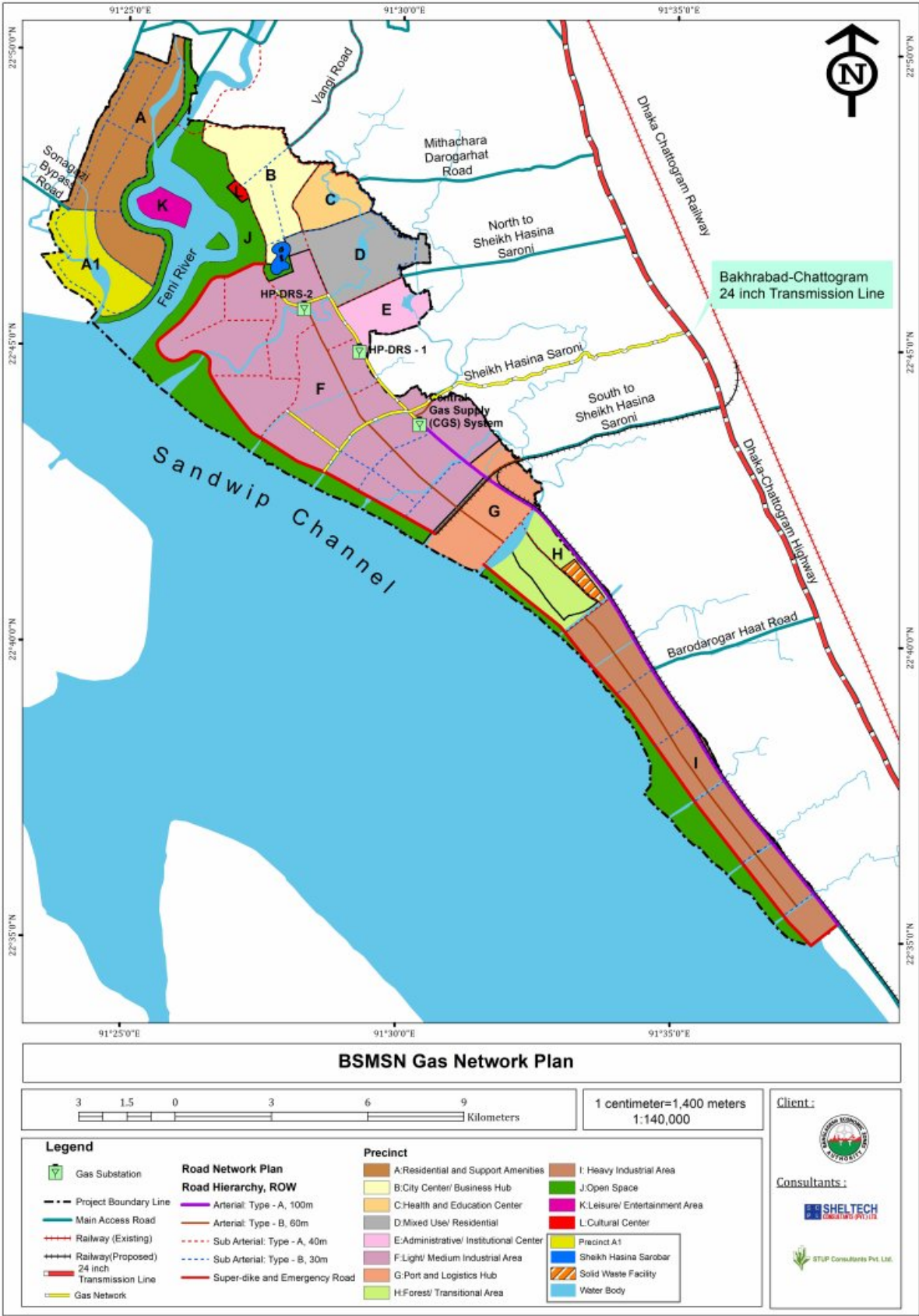

Figure 4-14: BSMSN Gas Network Plan



### 4.3.5 Cost Estimations for the Gas Network

Table 4-20: Cost Estimation for Gas Network Plan

Description of Items	Quantity/Units	Price Without Taxes		Phase I Cost Breakdown (Years 1-5)		Phase II Cost Breakdown (Years 6-10)		Phase III Cost Breakdown (Years 11-15)	
		(In Million Taka)	(In Million USD)	(In Million Taka)	(In Million USD)	(In Million Taka)	(In Million USD)	(In Million Taka)	(In Million USD)
<b>A customer having 100,000m3 montly, 300m3/hr,0.2 MMSCFD and a 500 meter service line (Customers operation hours=16 hr/day)</b>									
Service line=500meter (3")	1900	0.95	0.0112	0.475	0.005588	<b>0.285</b>	0.003353	0.19	0.002235
Internal line-200meter (4")	2700	0.54	0.0064	0.27	0.003176	<b>0.162</b>	0.001906	0.108	0.001271
Accessories Costs	LS	0.45	0.0053	0.225	0.002647	<b>0.135</b>	0.001588	0.09	0.001059
Construction Costs	LS	0.1	0.0012	0.05	0.000588	<b>0.03</b>	0.000353	0.02	0.000235
CP/line Protection Costs	As per design	0.3	0.0035	0.15	0.001765	<b>0.09</b>	0.001059	0.06	0.000706
CMS/ Gas Station Costs ( C type)	As per design	2	0.0235	1	0.011765	<b>0.6</b>	0.007059	0.4	0.004706
Security Money as per Approved Monthly Gas Load	10.7 tk/m3	3.21	0.0378	1.605	0.018882	<b>0.963</b>	0.011329	0.642	0.007553
Total Costa for One Customer		7.55	0.0888	3.775	0.044412	<b>2.265</b>	0.026647	1.51	0.017765
Total Costa for 925 Customers	<b>925</b>	<b>6983.75</b>	<b>82.1618</b>	<b>3491.875</b>	<b>41.08088</b>	<b>2095.13</b>	<b>24.64853</b>	<b>1396.75</b>	<b>16.4323</b>
<b>A customer having 60,000m3 monthly,1770m3/hr,1 MMSCFD and 500 meter service line S(Customer operation hours=16 hr/day)</b>									
Service line=500meter (4")	2700	1.35	0.0159	0.675	0.007941	<b>0.405</b>	0.004765	0.27	0.003176
Internal line-200meter (6")	4800	0.96	0.0113	0.48	0.005647	<b>0.288</b>	0.003388	0.192	0.002259
Accessories Costs	LS	0.5	0.0059	0.25	0.002941	<b>0.15</b>	0.001765	0.1	0.001176
Construction Costs	LS	0.2	0.0024	0.1	0.001176	<b>0.06</b>	0.000706	0.04	0.000471
CP/Line Protection Costs	As per design	0.4	0.0047	0.2	0.002353	<b>0.12</b>	0.001412	0.08	0.000941
CMS/ Gas Station Costs (F1 type)	As per design	3	0.0353	1.5	0.017647	<b>0.9</b>	0.010588	0.6	0.007059
Security Money as per Approved Monthly Gas Load	10.7 tk/m3	19.26	0.2266	9.63	0.113294	<b>5.778</b>	0.067976	3.852	0.045318

Description of Items	Quantity/Units	Price Without Taxes		Phase I Cost Breakdown (Years 1-5)		Phase II Cost Breakdown (Years 6-10)		Phase III Cost Breakdown (Years 11-15)	
		(In Million Taka)	(In Million USD)	(In Million Taka)	(In Million USD)	(In Million Taka)	(In Million USD)	(In Million Taka)	(In Million USD)
Total Costs for One Customer		<b>25.67</b>	<b>0.3020</b>	<b>12.835</b>	<b>0.151</b>	<b>7.701</b>	<b>0.0906</b>	<b>5.134</b>	<b>0.0604</b>
Total Costa for 150 Customers	<b>150</b>	<b>3850.5</b>	<b>45.3000</b>	<b>1925.25</b>	<b>22.65</b>	<b>1155.15</b>	<b>13.59</b>	<b>770.1</b>	<b>9.06</b>
<b>A customer having 998400m3 montly, 4000m3/hr,1.7 MMSCFD and 500 meter service line (Customer operation hour=24 hr/day)</b>									
Service line=500meter (4")	2700	1.35	0.0159	0.675	0.007941	<b>0.405</b>	0.004765	0.27	0.003176
Internal line-200meter (6")	4800	0.96	0.0113	0.48	0.005647	<b>0.288</b>	0.003388	0.192	0.002259
Accessories Costs	LS	0.5	0.0059	0.25	0.002941	<b>0.15</b>	0.001765	0.1	0.001176
Construction Costs	LS	0.2	0.0024	0.1	0.001176	<b>0.06</b>	0.000706	0.04	0.000471
CP/Line Protection Costs	As per design	0.6	0.0071	0.3	0.003529	<b>0.18</b>	0.002118	0.12	0.001412
CMS/ Gas Station Costs (F1 type)	As per design	3	0.0353	1.5	0.017647	<b>0.9</b>	0.010588	0.6	0.007059
Security Money as per Approved Monthly Gas Load	10.7 tk/m3	32.04864	0.3770	16.02432	0.188521	<b>9.61459</b>	0.113113	6.409728	0.075409
Total Costs for One Customer		<b>38.65864</b>	<b>0.4548</b>	<b>19.32932</b>	<b>0.227404</b>	<b>11.5976</b>	<b>0.136442</b>	<b>7.731728</b>	<b>0.090962</b>
Total Cost for 103 Customers	<b>103</b>	<b>3981.83992</b>	<b>46.8452</b>	<b>1990.92</b>	<b>23.42259</b>	<b>1194.55</b>	<b>14.05355</b>	<b>796.368</b>	<b>9.369035</b>
<b>A customer having 998,400 m3 monthly, 4000m3/hr, 1.7 MMSCFD and a 500 meter service line (Customers operation hours=24 hr/day)</b>									
Service line=500meter (6")	4800	2.4	0.0282	1.2	0.014118	<b>0.72</b>	0.008471	0.48	0.005647
Internal line-200meter (8")	6000	1.2	0.0141	0.6	0.007059	<b>0.36</b>	0.004235	0.24	0.002824
Accessories Costs	LS	0.6	0.0071	0.3	0.003529	<b>0.18</b>	0.002118	0.12	0.001412
Construction Costs	LS	0.3	0.0035	0.15	0.001765	<b>0.09</b>	0.001059	0.06	0.000706
CP/Line Protection Costs	As per design	0.8	0.0094	0.4	0.004706	<b>0.24</b>	0.002824	0.16	0.001882
CMS/ Gas Station Ccost (F3 type)	As per design	4.5	0.0529	2.25	0.026471	<b>1.35</b>	0.015882	0.9	0.010588
Security Money as per Approved Monthly Gas Load	10.7 tk/m3	32.04864	0.3770	16.02432	0.188521	<b>9.61459</b>	0.113113	6.409728	0.075409
Total Costs for One Customer		<b>41.84864</b>	<b>0.4923</b>	<b>20.92432</b>	<b>0.246168</b>	<b>12.5546</b>	<b>0.147701</b>	<b>8.369728</b>	<b>0.098467</b>

Description of Items	Quantity/Units	Price Without Taxes		Phase I Cost Breakdown (Years 1-5)		Phase II Cost Breakdown (Years 6-10)		Phase III Cost Breakdown (Years 11-15)	
		(In Million Taka)	(In Million USD)	(In Million Taka)	(In Million USD)	(In Million Taka)	(In Million USD)	(In Million Taka)	(In Million USD)
Total Costs for 22 Customers	<b>22</b>	<b>920.67008</b>	<b>10.8314</b>	<b>460.335</b>	<b>5.415706</b>	<b>276.201</b>	<b>3.249424</b>	<b>184.134</b>	<b>2.166283</b>
Grand Total (for 1200 different capacity customers)	<b>1200</b>	<b>15736.76</b>	<b>185.1384</b>	<b>7868.38</b>	<b>92.56918</b>	<b>4721.03</b>	<b>55.54151</b>	<b>3147.352</b>	<b>37.02767</b>





## 4.4 The Water Supply System

This section highlights the framework for the water supply system in BSMSN and focuses on water demand assessment, potential water supply sources, interventions required, land area to be ear-marked for different interventions and phase-wise cost involvement.

### 4.4.1 Background Analysis

The framework for the proposed water management system for BSMSN has been developed taking into consideration the constraints and recommendations made in the previous studies to meet the desired water goals. Findings/ recommendations from past studies have been duly taken into consideration with necessary improvements/ refinements.

One of the sources of water supply for BSMSN is the Feni River, which originates in the Indian territory and subsequently enters Bangladesh and gets discharged into the Sea. Being an International River, concurrence from the Government of India is essential prior to finalizing the scheme. **It should be noted that BEZA has sent notification to the Government of India informing them that Bangladesh/BEZA intends to use water from the Feni River for the BSMSN project. This is in compliance of the Government of Bangladesh's legal responsibilities.**

Note, a variety of global water system examples have been studied for BSMSN. Hence, good practices gathered in water management systems around the world have been utilized in framing the water supply works in BSMSN.

### 4.4.2 Water Demand Assessment

#### a. Unit Rate for Water Demand

**Industrial Usages:** Unit rate of water demand is considered to be 162 m<sup>3</sup>/day/ha (0.066 MLD/acre) of operating industrial land. The operating industrial land is considered to be about 60% of gross industrial land.

**Domestic and Non-domestic (other than Industrial) Usages:** The unit water demand for various categories of residential and non-residential usages adopted to arrive at the net water demand is summarized below:

- Residential : 150 litres / capita / day
- Non-domestic usage in different industries : 45 litres / head / day
- Water demand for other miscellaneous usages : 5% of non-domestic demand

#### b. Gross Water Demand

The loss on account of unaccounted for water (UFW) is considered to be 20% (*loss along the clear water transmission main and distribution system: 15% + loss at water treatment plant and along the raw water transmission main: 5%*), with break-up as given below:

- Raw water transmission : 0.5%
- Water treatment plant : 4.5%
- Clear water transmission : 5.0%
- Distribution network : 10.0%
- **Total** : **20.0%**

For desalination plants, the loss in the treatment process is considered to be 150% of the production rate. The loss quantity is brine water, which shall be returned back to the sea.

For a well-managed water supply system, the UFW losses is typically in the range of 10-12% of the net water demand at the consumer end. With metered water supply connection to all the consumers within BSMSN and good water management practices, the UFW losses (which is considered to be 20% at this stage) can be reduced

further down. It is suggested to carry out “water loss management study” once the industrialisation pattern of BSMSN is substantially developed and water requirement of the area can be assessed more realistically to arrive at a firmer figure for the water losses. Requirement for further upgrading of the water supply sources including treatment requirement can be decided accordingly.

The estimated phase-wise net and gross water requirement to meet the water demand for BSMSN considering 20% losses, as indicated above, is summarized below.

Table 4-21 Estimated Phase-Wise Net and Gross Water Requirements

Row #	Description	Water Demand (MLD)			
		2025	2030	2035	2040
1	Industrial water demand	242	337	474	665
2	Domestic and non-domestic water demand	57	82	119	174
3	Net water requirement at consumer end	299	419	593	839
4	Water requirement at inlet of distribution network considering losses in distribution network	332	466	659	932
5	Water requirement at inlet of clear water transmission main considering losses in clear water transmission	350	490	694	981
6	Water requirement at inlet of water treatment plant considering inter-plant losses	366	513	726	1028
7	Quantum of raw water to be drawn inclusive losses in raw water transmission	368	516	730	1033

- Row 3: Net water requirement at consumer end = Row 1 + Row 2
- Row 4: Water requirement at inlet of distribution network = Row 3 / [(100 - 10.0)%]
- Row 5: Water requirement at inlet of clear water transmission main = Row 4 / [(100 - 5.0)%]
- Row 6: Water requirement at inlet of water treatment plant = Row 5 / [(100 - 4.5)%]
- Row 7: Quantum of raw water to be drawn = Row 6 / [(100 - 0.5)%]

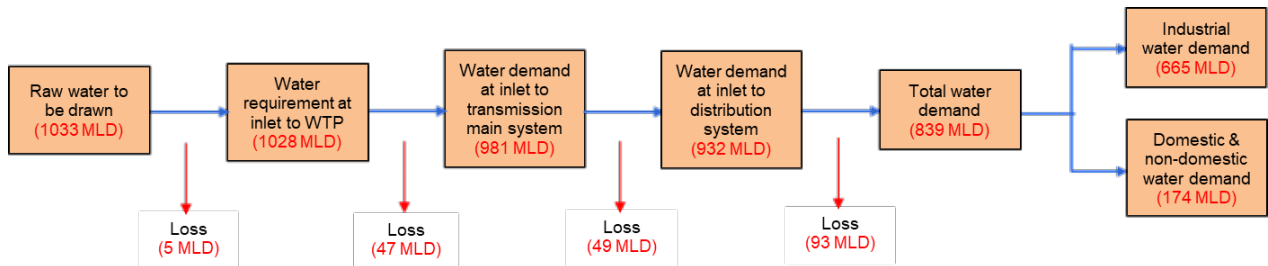

Figure 4-15: Representation of Ultimate Water Demand for Year 2040 For BSMSN

Effort shall be made to recycle/ reuse the wastewater to the extent possible and reduce unaccounted for water (UFW) losses. In the process, the water demand calculations may undergo changes, likely to get reduced. It is suggested to carry out “water balance study” in the year 2030. By that time, it is expected that the industrialisation pattern of BSMSN will be substantially developed and water requirement of the area can be assessed more realistically. Moreover, the industrial demand for recycled wastewater after treatment will be clearer. Capacity requirement of various functional units of the water supply system beyond year 2030 to be further reviewed based on the findings of water balance study.

An assessment has been made under this study to evaluate the extent of water treatment necessary and quantum of raw water required to be drawn if 60% of the wastewater generated can be recycled after necessary treatment. Considering wastewater generation as 80% of the net water demand, the quantum of recycled water after treatment works out to about 333 MLD. In the process the quantum of raw water to be treated works out to about 700 MLD.

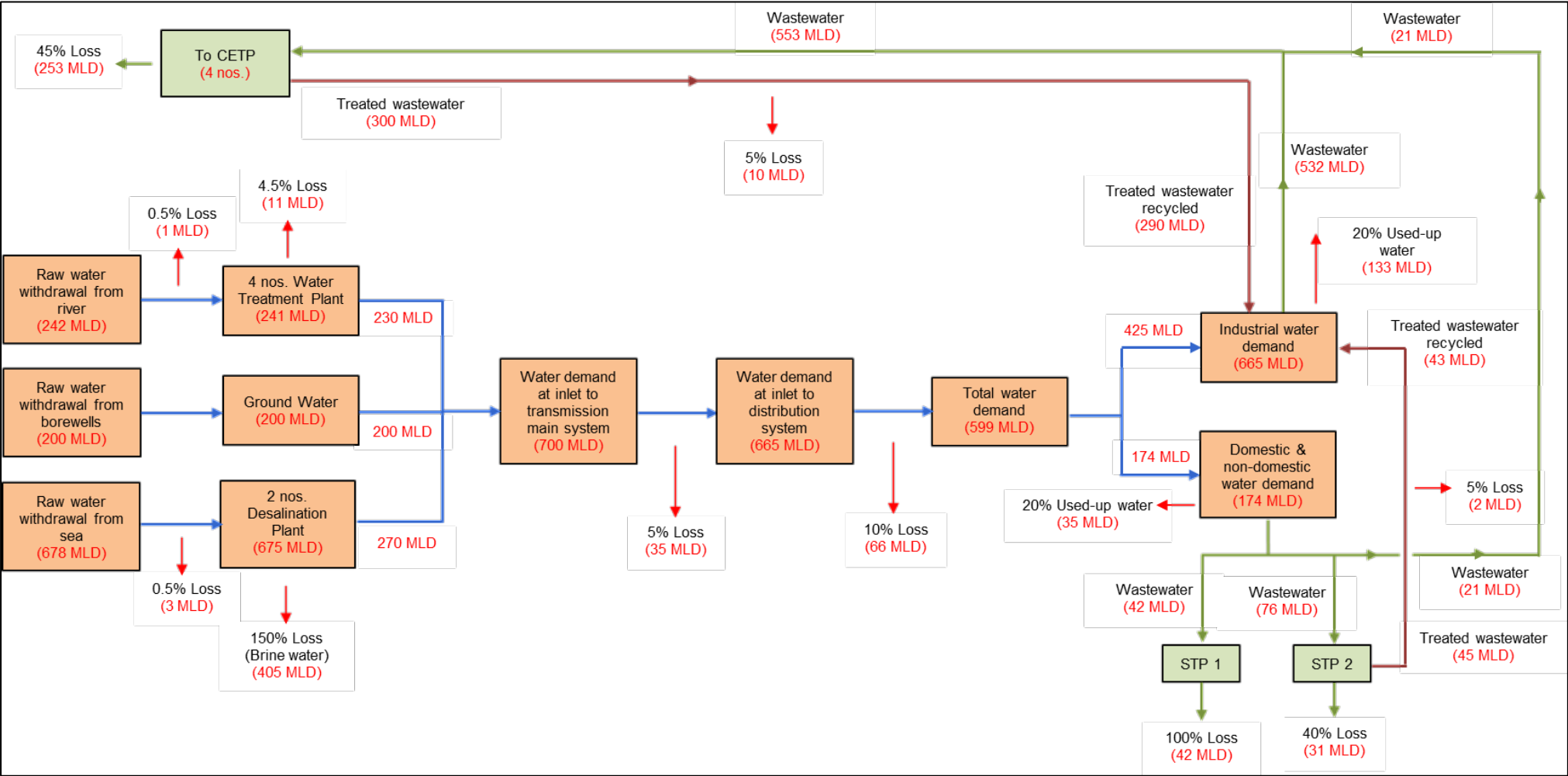

Figure 4-16 Water Balance Diagram for Year 2040 for BSMSN



The quantum of recycled wastewater for industrial usage is dependent on the market demand. The quantity as mentioned above is the maximum quantity that can be recycled. If demand for recycled wastewater is less, the quantity of raw water drawal from sea will be more.

Considering the geographic barrier caused by Feni River, the wastewater generation from the area lying to the west of the river (Precinct A) is not suggested for recycling. **Figure 4-16** illustrates the water balance diagram of BSMSN for the ultimate requirement of year 2040.

**c. Yearly Projections for BSMSN Water Demand**

The water demand in the BSMSN is expected to grow progressively. The water supply improvement measure is proposed to be taken-up in phased manner, in commensuration with the increment in water demand. Assessed water demand for various years under consideration and the production of water from surface water, ground water and desalination plant, as being planned for BSMSN is given below, duly taking into consideration recycling of wastewater after treatment for industrial usage. Same needs to be re-evaluated on a regular basis to work out further improvement measures needed.

Desalination has to be carefully included as source of water for BSMSN after careful assessment of all available water sources viz. maximizing wastewater recovery and recycling, reduce and optimization of process water etc. Desalination, if not optimized, can affect the competitiveness of BSMSN (a too high water cost can divert investments to other zones). A systemic approach is suggested to be followed in proceeding with prioritization analysis of water sources for any sub-zone that is developed in BSMSN in the framework of the master plan recommendations.

Table 4-22 Water Production Planning

(All figures are in MLD)

Description	Planning Horizon													
	Phase 1						Phase 2						Phase 3	Phase 4
	2020	2021	2022	2023	2024	2025	2026	2027	2028	2029	2030	2035	2040	
Quantum of Treated Water Requirement	30	50	50	150	250	350	380	410	450	480	525	700	1033	
Quantum of Recycled Wastewater				20	20	80	80	80	100	120	150	200	333	
Treated Water Required Considering Recycled Wastewater	30	50	50	130	230	270	300	330	350	360	375	500	700	
<b>Water to be drawn from surface water source (excluding sea water)</b>														
• Reservoir upstream of Muhuri Dam with regulator – Phase 1				50	50	50	50	50	50	50	50	50	50	
• Reservoir upstream of Muhuri Dam with regulator – Phase 2							50	50	50	50	50	50	50	
• Reservoir Upstream of Musapur Regulator									40	40	40	40	40	

Description	Planning Horizon													
	Phase 1						Phase 2						Phase 3	Phase 4
	2020	2021	2022	2023	2024	2025	2026	2027	2028	2029	2030	2035	2040	
• Mohra Treatment Plant Phase 2					90	90	90	90	90	90	90	90	90	
<b>Total from Surface Water Source</b>				50	140	140	190	190	230	230	230	230	230	
<b>Water to be drawn from ground water source</b>														
- Phase 1	30	50	50	50	50	50	50	50	50	50	50	50	50	
- Phase 2							50	50	50	50	70	70	70	
- Phase 3												80	80	
<b>Total from Ground Water Source</b>	30	50	50	50	50	50	100	100	100	100	120	200	200	
<b>Total from Surface Water and Ground Water Source</b>	30	50	50	100	190	190	290	290	330	330	350	430	430	
Production Requirement from Desalination Plant	0	0	0	30	40	80	10	40	20	30	25	70	270	
<b>Production Capacity from Desalination Plant Proposed</b>	-	-	-	50	50	50	50	50	50	50	50	100	270	

#### 4.4.3 Source of Raw Water

Extensive studies and analysis has been carried out to identify the potential sources of raw water to meet the water demand for BSMSN. Various potential sources of raw water and expected quantum of raw water that can be utilized/ withdrawn to meet the water requirement of BSMSN is summarized below.

- **Reservoir Upstream of Muhuri Dam with Regulator constructed over Feni River:** 100 MLD of raw water can be withdrawn from the reservoir upstream of Muhuri Dam with 20 Vent Regulator constructed under Muhuri Irrigation project.
- **Reservoir Upstream of Musapur Regulator constructed over Little Feni River:** 40 MLD of raw water can be withdrawn from the Musapur Regulator location to meet the water demand of BSMSN.
- **Mohra Treatment Plant Phase 2:** The water treatment plant, located at a distance of about 65 km from BSMSN is under construction with Halda River in Chittagong as source of raw water. About 90 MLD of treated water is available to supply to BSMSN.
- **Ground Water:** Total volume of ground water resource is estimated to be around 200 MLD considering 10m drawdown in the aquifer. Maximum 100 wells are proposed be installed with 20 hours operation/ day and considering withdrawal rate of 1 cusec (28.3 litre/sec) for each production well.
  - It is further suggested to provide observation wells (at least 1 number per 1000 acres area) for obtaining water level, water temperature, or quality data.

- To prevent dwindling of ground water table due to over-extraction of ground water, rain water harvesting to recharge the ground water is suggested.
- **Recycled Wastewater After Treatment:** About 333 MLD of wastewater generated from BSMSN is suggested to be recycled to meet the industrial demand after treatment in the proposed common effluent treatment plants (CETPs) and sewage treatment plant (STP).
- **Sea Water:** About 678 MLD of raw water shall be withdrawn from the Sandeep Channel (sea water) and to be treated by constructing desalination plant to meet the total water requirement of BSMSN.

Two Desalination Plants are proposed for the BSMSN Master Plan Area. The locations of the plants shall be carefully selected depending upon the land use planning and bathymetry of the drawal position at sea.

Construction of a **Coastal Reservoir** is a possible alternative to be considered as a potential source of raw water in lieu of sea water. A coastal reservoir is a freshwater reservoir located in the sea at the mouth of a river with a sustainable annual flow which otherwise gets lost to the sea. All a coastal reservoir needs to be effective is an impermeable barrier between the fresh river water and the salty sea water.

*Coastal reservoir, as source of water supply and flood risk management, is still in conceptual stage for BSMSN. Detailed technical, financial, environmental and social assessment needs to be carried out under a separate study to ascertain its techno-economic viability, environmental/ social sustainability etc. prior to taking a decision regarding construction of the coastal reservoir. This may be a long-term proposition. To fulfill the immediate need, more conventional practice of water supply system based on surface water sources (fresh water/ sea water) is felt to be the solution for the time being.*

**Rainwater Harvesting for Artificial Recharge to Groundwater**

It is well known that excess ground water abstraction can lead to dwindling of the ground water table or even intrusion of saline water due to imbalance in ground water recharge and abstraction volume. Such situation should be avoided either by decreasing the dependency on ground water or gradually increasing the ground water storage volume by artificial recharge to the aquifer systems.

Plastic Tunnel for Rainwater Infiltration and Attenuation is suggested to be used for groundwater recharging. This is a tunnel shaped modular element made of regenerated HDPE, designed for creation of underground systems for dispersion of rainwater to the subsoil. The dispersing chambers make it possible to build a high-capacity underground system capable of temporarily accumulating rainwater from the surface collection network.



**Actions to be taken for Effective Rainwater Harvesting Programme**

Actions to be taken for effective rainwater harvesting and recharging of ground water are:

- Rainwater harvesting must be widely practiced all over the BSMSN to effect large scale replenishment.

- Directives may be issued to all the investors to carry out rainwater harvesting and make it mandatory to charge rooftop rainwater to the productive aquifer.
- Runoff generated from first flush of rain should be directed to drainage outlet, instead of recharging to prevent possibility of any contamination to ground water.
- Harvesting schemes must be prepared and implemented under expert technical care and proper maintenance must be ensured. Or else, instead of improvement, there would be adverse impact. It may be worth to mention here that any degree of pollution caused to aquifer is irreversible.

#### 4.4.4 Different Water Supply Components

Major components of the water supply system for the BSMSN shall essentially include the following:

##### Raw Water Drawal Arrangements

- There shall be an intake well structure and pump house at the tapping point at the pre-determined location based on surface water source bathymetry. The intake structure shall be connected to the shore by an approach bridge, which in addition carries the raw water pumping main for conveying the raw water to the water treatment plant.

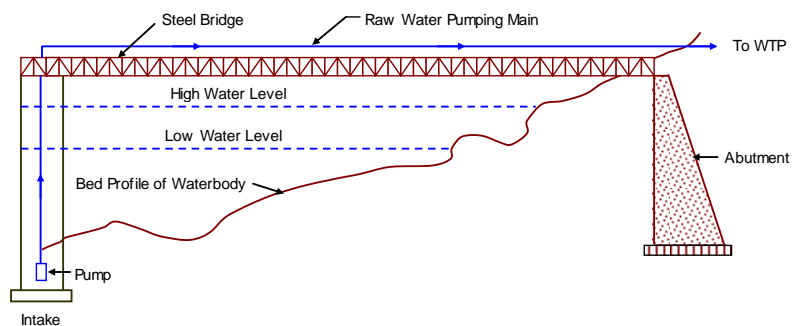

##### Raw and Treated Water Pumping Station

- The raw and treated water pumping station shall be designed with modular approach of development. Under 1<sup>st</sup> stage of development works capacity of pumps shall be kept adequate to meet the demand upto initial 15 years or so. Under 2<sup>nd</sup> stage of development works capacity of pumps shall be provided to meet the ultimate demand upto project horizon I.E. year 2040. The civil construction shall however be done considering the ultimate demand.

##### Raw and Treated Water Transmission Main

- The recommended pipe material is ductile iron with cement mortar lining inside for pipe size upto 1000 mm diameter; mild steel for pipe size exceeding 1000 mm.

##### Water Treatment Plant

The treatment technology being suggested for the water treatment plant is based on the following pre-conditions:



- Has got a proven track record of satisfactory performance over years, in similar geographic environment
- Easy availability of skilled personnel to operate and maintain the system
- Requirement of lesser land area, which in turn reduces the capital investment
- The technology should be capable to withstand climatic condition prevailing within the project site

The water treatment technology to be used is proposed to be consisting of the unit processes viz. coagulation, flocculation, clarification, filtration and desalination (if raw water source is sea water, otherwise not required) followed by disinfection. Schematic representation of the water treatment technology proposed to be adopted is given below:

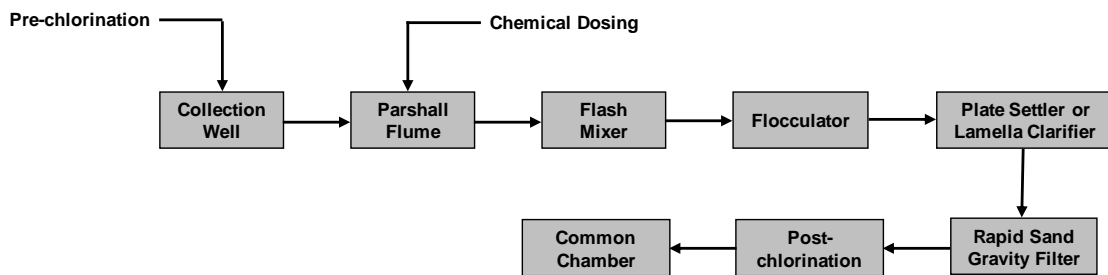

Steps to be followed for Desalination Plants shall include:

- Pre-treatment of the raw sea water by coagulation, flocculation, gravity and pressure filtration
- Reverse osmosis (RO) process to separate the freshwater
- Post-treatment process by adding chemicals to re-mineralize the desalinated seawater and adjustment of pH of the treated water
- Treated water storage reservoir

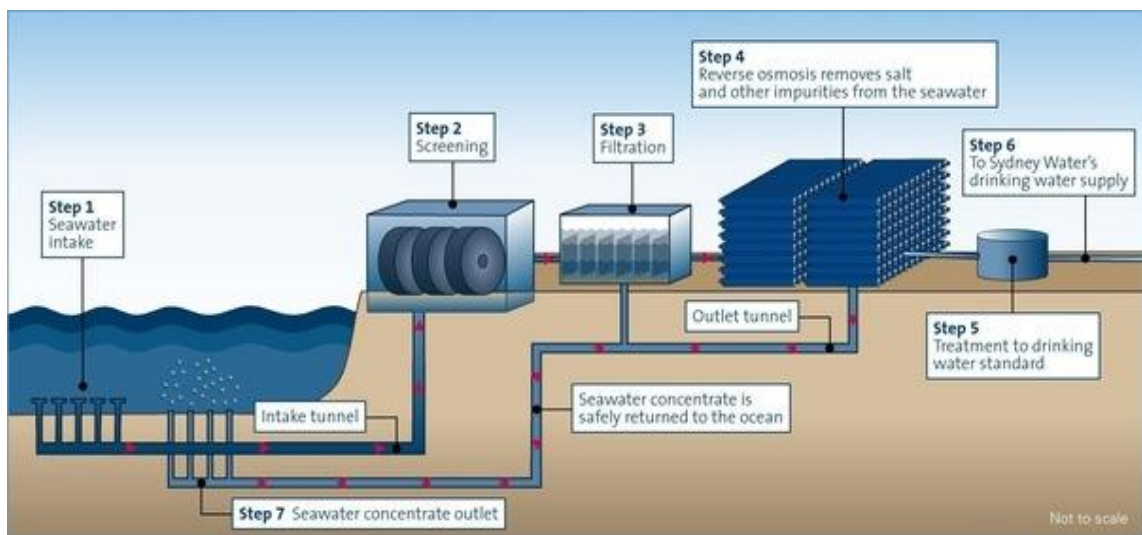

Figure 4-17: Typical Process Diagram of a Desalination Plant

### **Distribution Network up to Consumer End**

- The distribution main network shall extend upto the consumer end. Planning of the distribution main network shall be carried out keeping into account landuse pattern, planned road network and ground topography of the area. Suitable looping arrangement in the distribution network with valve control arrangement is suggested to ensure greater flexibility in operation of the system. Recommended pipe material is ductile iron with cement mortar lining inside for pipe size 100 mm diameter and above; HDPE of pressure rating PN6 for pipe size below 100 mm.
- Design of all the components of the water supply system shall be carried out based on best engineering practices and keeping into consideration overall cost economy, budgetary provision, sustainability, ease in execution, operation and maintenance. Aesthetics shall be kept into consideration for all the over-ground structures matching with the surroundings.
- Water supply system shall be developed in phased manner depending upon increment in demand. Modular approach is recommended to be followed for design of the water treatment plant and different pumping stations.
- Design of the different components of the water supply system shall be carried out in accordance with the accepted design norms and criteria and in close coordination with the Client/ other stakeholders.

#### **4.4.5 Interventions Required for the Water Supply System**

The interventions required for the introduction of a water supply system into BSMSN includes:

##### **Interventions required outside BSMSN to withdraw raw water, get it treated and transmit the treated water upto BSMSN boundary (Off-site Improvement measures)**

- Raw water drawal arrangement comprising intake arrangement with pumping arrangement and approach bridge (3 nos.) (raw water drawal arrangement for Mohra WTP is being taken-up under a separate project)
- Raw water transmission main system to the 3 WTPs (raw water transmission main for Mohra WTP is being taken-up under a separate project)
- 3 numbers WTPs (Mohra WTP is being taken-up under a separate project)
- 4 numbers treated water storage reservoir - cum - pumping station
- Treated water transmission main system from the 4 treated water pumping stations upto BSMSN boundary

##### **Interventions Required Within BSMSN (On-site Improvement Measures)**

- Raw water drawal arrangement from sea comprising intake arrangement with pumping arrangement and approach bridge (2 nos.)
- Raw water transmission main system to the 2 desalination plants
- 2 numbers desalination plants
- 2 numbers treated water storage reservoir - cum - pumping station
- Treated water transmission main network from the 2 numbers treated water storage reservoir - cum - pumping station and extension of the transmission main system from BSMSN project area boundary (considered under off-site improvement measures) upto strategic locations
- 25 numbers of underground storage reservoir - cum - pumping station
- Distribution main network (700 km)
- 100 numbers production well inclusive of pump house, chlorination facility
- 35 km long recycling wastewater line
- Arrangement for rainwater harvesting at strategic locations

- To have a more or less even distribution of flow as per requirement at requisite pressure, the entire area of BSMSN has been divided into 25 nos. of independent water supply zones, each being served with individual pumping system. Command area of individual water supply zones have been judiciously decided considering the precinct boundaries, natural barriers (existing drainage channels) and major arterial roads (ROW of 60m and 100m) to minimize the number of crossings to such barriers and also to restrict the capacity requirement of the pumping machineries.
- The underground/ semi-underground reservoirs to be constructed for pumping will be fed by a network of transmission main system originating from the treated water pumping station to be located inside the boundary of the water treatment plant (WTP).
- Location of each utility installation point has been selected as per the prescribed guidelines mentioned in Section 3.1 of Chapter 3.

Figures 4-18 and 4-19 show the proposed water supply system planning with locations of ground level storage reservoirs (GLSRs) including their command areas.

Salient details of the suggested water supply system is given in Annexure 4.6.

Land area requirements of various installations for water supply system is summarized in Table 4-23. For details refer to Annexure 4.6.

Table 4-23: Land Area Requirements for Various Installations for the Water Supply System

Description	Land Area Requirements
<b>Off-site Improvement Measures</b>	
Raw water pumping station (3 nos.)	No land area is required. The structure may be constructed directly over the source
Water treatment plant (3 nos.)	14 ha (36 acres)
Treated water pumping station (4 nos.)	3.3 ha (8 acres)
<b>Total Land area for Off-site Improvement Measures</b>	<b>17.3 ha (44 acres)</b>
<b>On-Site Improvement Measures</b>	
Raw water pumping station (2 nos.)	No land area is required. The structure may be constructed directly over the source
Desalination Plant (2 nos.)	50 ha (125 acres)
Treated water pumping station (2 nos.)	2.7 ha (7 acres)
Storage reservoir with pumping arrangement (25 nos.)	14 ha (34 acres)
Total Land area required for On-site Improvement Measures	71.3 ha (166 acres)
<b>Total Land area for Off-site and On-site Improvement Measures</b>	<b>83.6 ha (210 acres)</b>

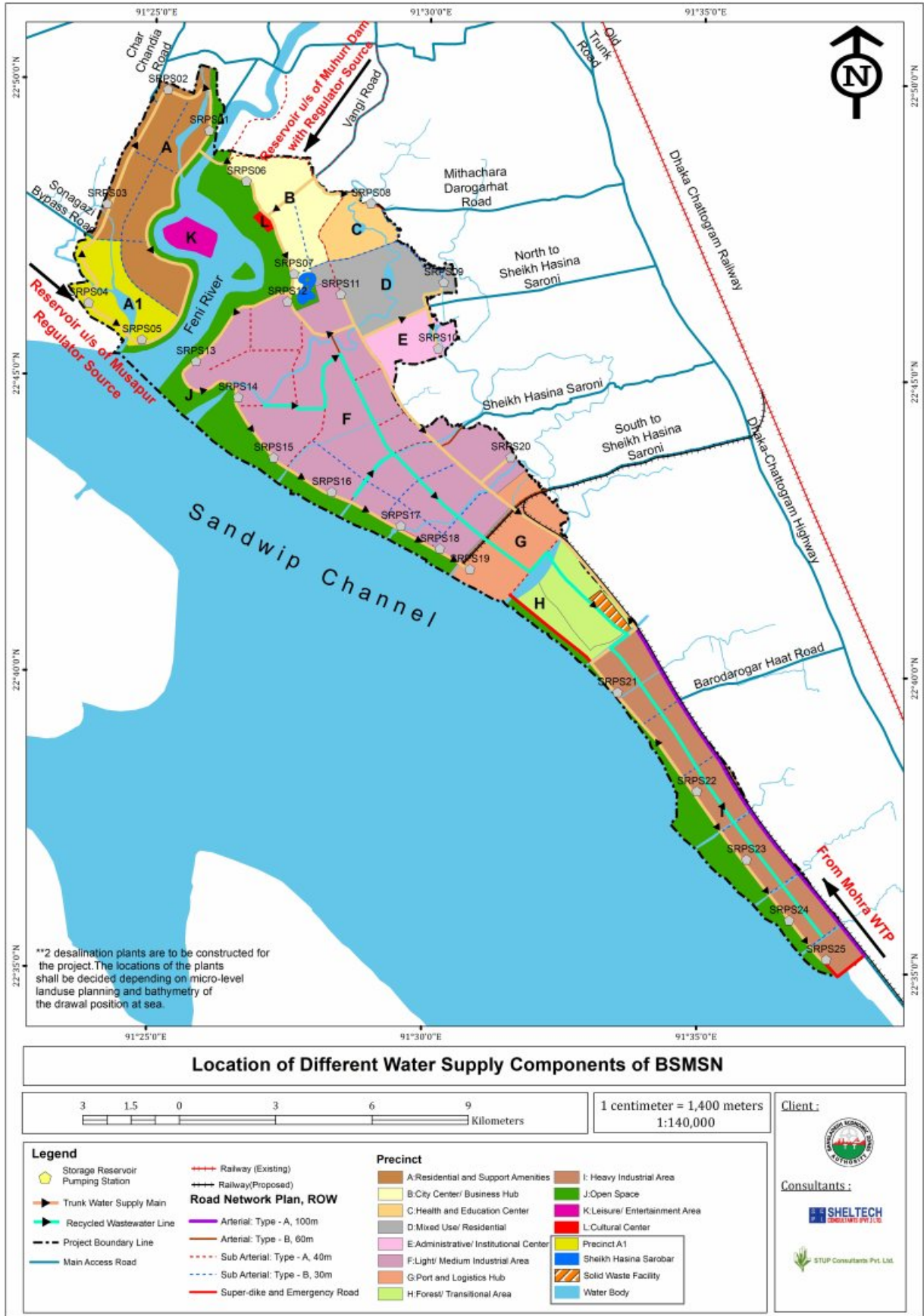

Figure 4-18: Location of Different Water Supply Components of BSMSN

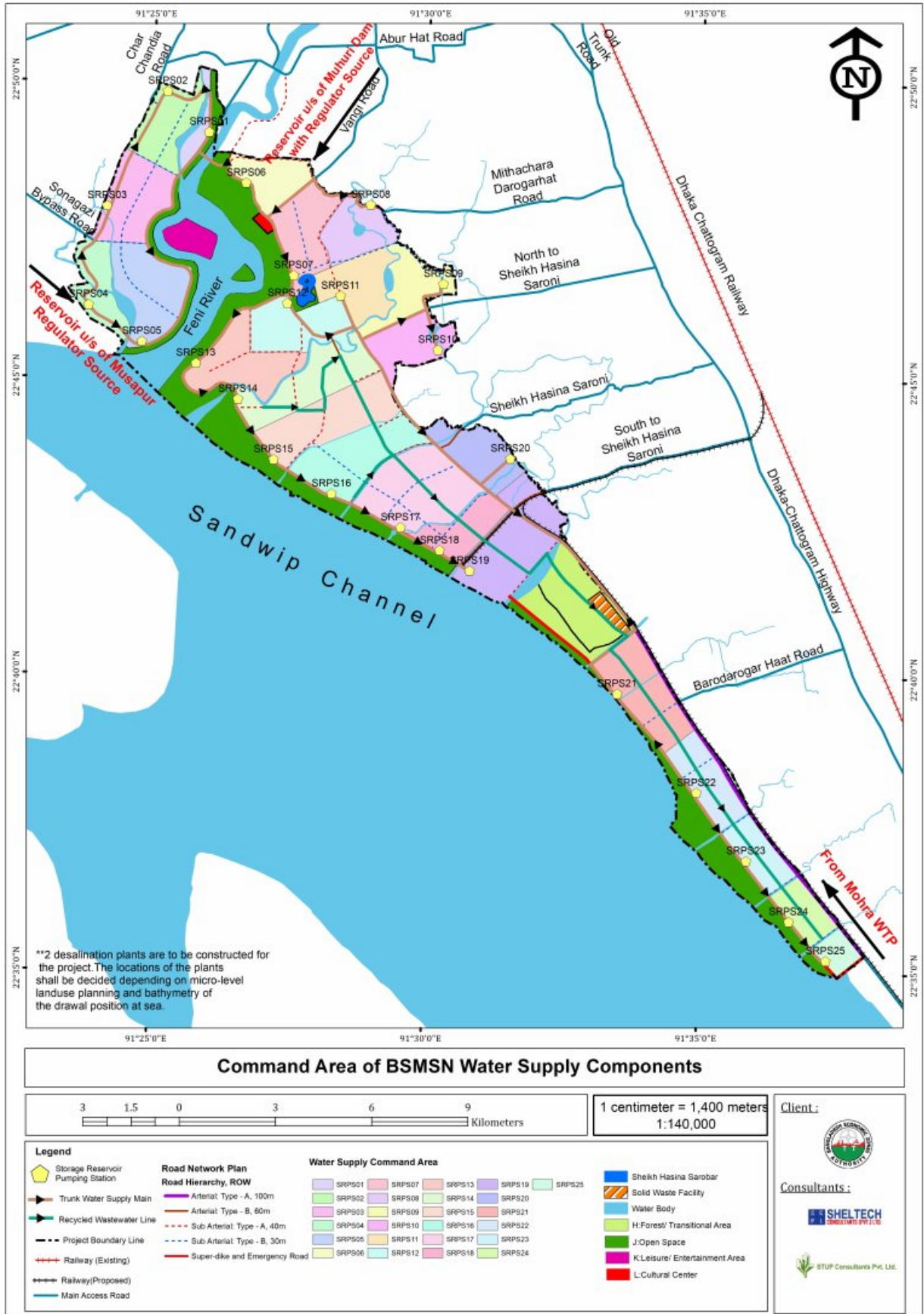

Figure 4-19: Command Area of BSMSN Water Supply Components

#### 4.4.6 Cost Estimations for Water Supply System

##### a. Off-Site Infrastructure Costs

Off-site water supply system costs are presented in **Table 4-24** below:

*Table 4-24 Off-Site Infrastructure Cost for Water Supply System*

Description of Item	Quantity/ Unit	Price Without Tax		Phase I Cost Breakdown (Years 1-5)		Phase II Cost Breakdown (Years 6-10)		Phase III Cost Breakdown (Years 11-15)	
		(In Million Taka)	(In Million USD)	(In Million Taka)	(In Million USD)	(In Million Taka)	(In Million USD)	(In Million Taka)	(In Million USD)
Raw water intake arrangement including pumping station and approach bridge	3 nos.	1258.0	14.8	450.5	5.3	807.5	9.5	-	-
Raw water transmission main	15 km	807.5	9.5	297.5	3.5	510.0	6.0	-	-
Water treatment plant	3 nos.	2142.0	25.2	765.0	9.0	1377.0	16.2	-	-
Treated water pumping station	4 nos.	484.5	5.7	289.0	3.4	195.5	2.3	-	-
Treated water transmission main	130 km	10115	119.0	7905.0	93.0	2210.0	26.0	-	-
<b>Total</b>		<b>14807.0</b>	<b>174.2</b>	<b>9707.0</b>	<b>114.2</b>	<b>5100.0</b>	<b>60.0</b>	<b>-</b>	<b>-</b>
Engineering Fees (5%)		740.4	8.7	485.4	5.7	255.0	3.0	-	-
Contingency (15%)		2221.1	26.1	1456.1	17.1	765.0	9.0	-	-
Taxes (18%)		2665.3	31.4	1747.3	20.6	918.0	10.8	-	-
<b>Off-Site Water Supply System Total</b>		<b>20433.8</b>	<b>240.4</b>	<b>13395.8</b>	<b>157.6</b>	<b>7038.0</b>	<b>82.8</b>	<b>-</b>	<b>-</b>

##### b. On-Site Infrastructure Costs

The on-site water supply system costs are illustrated in **Table 4-25** below:

*Table 4-25: On-Site Infrastructure Cost for Water Supply System*

Description of Item	Quantity/ Unit	Price Without Tax		Phase I Cost Breakdown (Years 1-5)		Phase II Cost Breakdown (Years 6-10)		Phase III Cost Breakdown (Years 11-15)	
		(In Million Taka)	(In Million USD)	(In Million Taka)	(In Million USD)	(In Million Taka)	(In Million USD)	(In Million Taka)	(In Million USD)
Raw water intake arrangement including pumping station and approach bridge	2 nos.	10089.5	118.7	3468.0	40.8	-	-	6621.5	77.9
Raw water transmission main	8 km	1224.0	14.4	238.0	2.8	-	-	986.0	11.6
Desalination plant	2 nos.	11475.0	135.0	2125.0	25.0	-	-	9350.0	110.0
Treated water pumping station	2 nos.	484.5	5.7	144.5	1.7	-	-	340.0	4.0
Treated water transmission main	110 km	6545.0	77.0	1955.0	23.0	3272.5	38.5	1317.5	15.5
Storage reservoir with	25 nos.	1037.0	12.2	255.0	3.0	416.5	4.9	365.5	4.3

Description of Item	Quantity/ Unit	Price Without Tax		Phase I Cost Breakdown (Years 1-5)		Phase II Cost Breakdown (Years 6-10)		Phase III Cost Breakdown (Years 11-15)	
		(In Million Taka)	(In Million USD)	(In Million Taka)	(In Million USD)	(In Million Taka)	(In Million USD)	(In Million Taka)	(In Million USD)
pumping arrangement for distribution system									
Distribution Main Network	700 ksm	10710	126.0	2142.0	25.2	4318.0	50.8	4250.0	50.0
Production Well inclusive of Pump House, Chlorination Facility	200 nos.	425.0	5.0	110.5	1.3	144.5	1.7	170.0	2.0
Wastewater recycling line	35 km	5355.0	63.0	510.0	6.0	561.0	6.6	4284.0	50.4
Development of rainwater harvesting system		4250.0	50.0	425.0	5.0	1275.0	15.0	2550.0	30.0
<b>Total</b>		<b>51595.0</b>	<b>607.0</b>	<b>11373.0</b>	<b>133.8</b>	<b>9987.5</b>	<b>117.5</b>	<b>30234.5</b>	<b>355.7</b>
Engineering Fees (5%)		2579.8	30.4	568.7	6.7	499.4	5.9	1511.7	17.8
Contingency (15%)		7739.3	91.1	1706	20.1	1498.1	17.6	4535.2	53.4
Taxes (18%)		9287.1	109.3	2047.1	24.1	1797.8	21.2	5442.2	64.0
<b>On-Site Water Supply System Total</b>		<b>71201.2</b>	<b>837.8</b>	<b>15694.8</b>	<b>184.7</b>	<b>13782.8</b>	<b>162.2</b>	<b>41723.6</b>	<b>490.9</b>

## 4.5 Storm Water Drainage System

### 4.5.1 Background Analysis

The area ear-marked for BSMSN, is a naturally reclaimed land from sea, sloping from north-east to south-west. Storm runoff generated from the entire area of BSMSN and its surroundings gets drained to the sea through a number of natural drainage channels passing through the BSMSN viz. Ichakhali Khal, Bamansundar Khal, Shaher Khali Khal etc. All together there are 13 number of drainage channels, all getting discharged to the sea, apart from Feni River, which passes through BSMSN before confluencing to the sea.

The entire area of BSMSN, which is mostly low-lying, is currently in the process of infilling to a level of about 7.0m MSL. Average height of in-filling is about 3.4m. The project area is cyclone prone. A super dyke is under construction (dyke top level is fixed at 9.0m MSL) to prevent ingress of sea water to the BSMSN, even during the event of any cyclonic storm.

With infilling of the entire project area and construction of the super dyke, natural drainage system of the area will get affected. Development of proper drainage network with optimum utilization of the existing natural drainage channels is of utmost importance, without which severe and prolonged water logging all over the project area is anticipated.

To encourage ground water recharging and to attenuate the flow rate through the drainage channels, a number of water bodies are going to be established for the entire BSMSN. This, in addition, will have the advantage of storage of water to meet fire demand, in case of exigency.

Rainwater harvesting shall be extensively adopted for ground water recharging/ other possible uses. Under normal rainfall event, major portion of the rain precipitated will be utilized for ground water recharging, filling-up of different water bodies to be developed within the project area etc. It may be noted that drainage system of an area is designed considering short term - high intensity rainfall data, corresponding to pre-decided storm

frequency. Under such scenario, only a fraction of the rain precipitation gets utilized in the process of ground water recharging. Rest portion will get lost as surface runoff, which needs to be evacuated quickly through a properly designed storm water drainage network. Or else, this will result surface inundation.

All the existing drainage channels, passing through BSMSN are connected to the sea and have got strong tidal influence. To prevent ingress of sea water to the drainage channels during high tide condition, at all the existing outlet positions sluice gates are to be installed. Consequently, gravity discharge of storm water to the sea will not be possible during the time of closure of the gates owing to high tide condition. Under such situation the only left out option will be to pump out the storm runoff generated to the sea.

#### 4.5.2 Rainfall Pattern

The entire project area is prone to cyclonic storms. Effective storm water drainage system design of an area demands a realistic assessment of rainfall characteristics of the area with probable interval of occurrence for such rainfall event (I.E. frequency of occurrence). Rainfall pattern of an area is evaluated by statistical analysis of short term - high intensity rainfall records based on historical rainfall data.

For most realistic assessment of the rainfall pattern it is essential to have 15-30 minutes interval rainfall records based on rainfall histogram for a prolonged period (preferably not less than 15 years). Higher the period of availability of historical rainfall records, more realistic will be the rainfall analysis findings. Historical rainfall records will be collected from Sitakunda meteorological station which is in proximity to BSMSN.

Rainfall analysis including development of the rainfall hyetograph shall be carried out prior to taking-up detail engineering design for drainage system.

#### 4.5.3 System Planning

All the existing natural drainage channels passing through BSMSN and carrying storm runoff generated from area outside BSMSN shall be retained. Detailed hydrologic analysis shall be carried out or collected from appropriate authority during the stage of detailed engineering design to ascertain storm runoff likely to pass through the drainage channels and their carrying capacities required. An assessment, however, has been made under this study to ascertain the maximum rate of flow likely to pass through individual drainage channels and sectional area requirement to meet the purpose. With change in landuse characteristics of the area, the storm runoff is likely to increase over time. To account for the enhanced storm water flow rate, the natural drainage channels shall be re-sectioned suitably with side lining/ grass turving and increase in width/ depth, as may be required. Considering the future development pattern, meandering portions of the drainage channels might require straightening. Special care shall be taken at such portions to ensure that any such man-made changes in flow path of the channels do not have any adverse impact, considering the natural tendency of drainage channels to return back to their original natural course. Moreover, it has to be ensured that at such locations the drainage channels shall have capacity equal to the carrying capacity of the existing channel to be re-routed or design storm runoff, whichever is more.

The drains shall be of rectangular RCC section. In the residential/ commercial locations and all other non-industrial areas the proposed storm drains shall be fully covered. Arrangement of removal of slabs or providing manhole covers at interval not exceeding 30m shall be provided to facilitate regular cleaning/ desilting of the drains. For other areas it may be kept open considering easier maintenance. Suitably designed culverts need to be provided at all road crossings. Storm water inlet arrangement needs to be provided at interval not exceeding 10m to allow ingress of storm runoff into the system.

It will be the responsibility of individual plot owners to develop drainage system within their premises and get them connected to the drains to be constructed under this project. Invert levels of the drain shall be kept sufficiently deep to ensure gravity connection to the drains from individual plots.

In addition, storm water outlets to natural drainage channels are proposed at interval varying between 250-



400m depending on the proposed road network of the area to facilitate direct discharge of storm runoff for the plots adjoining the drainage channels, which in turn will reduce the load to the drainage network being developed. Wherever applicable, individual plot owners may be encouraged to provide more number of outfalls to the natural drainage courses while developing storm water drainage network within their premises.

Considering tidal influence to the drainage outlets, as additional safety measure, controlling arrangements shall be introduced into the system at or near storm water drainage outlets to prevent backflow of water during high tide or high stage of water in the receiving drainage channels during tidal lockage period. Sluice gate and flap gates are the possible controlling device to prevent the backflow.

Flap gates are functionally best suited controlling arrangement, as this is automatically controlled and needs no manual intervention. But it needs regular maintenance of the receiving water body to ensure smooth operation of the gate. Siltation of channels beyond the bottom level of the gate will prevent proper functioning of flap gates. Keeping this into consideration flap gates shall be provided wherever it is possible to maintain the outfall level of the storm water drains at least 1.2m above the design bed level of the drainage channel. The flap gates to be installed in the system are recommended to be made of HDPE which are light weight and as such will operate with small head difference. Wherever, such conditions cannot be maintained, sluice gates need to be provided in the system in lieu of flap gates.

Hydraulic modelling is recommended to be carried out to have a fair idea of hydraulic behaviour of the system to different boundary conditions of the proposed drainage system during the stage of detailed engineering design. The basic objective of hydraulic modelling is to establish an integrated hydrologic and hydraulic model of drainage system in the area. Hydraulic modelling, using well-established modelling software, is recommended to have a fair idea regarding the following:

- To determine system capacity
- Performance of different outfalls provided
- Adequacy of sizing of different system components
- Extent and duration of flooding, which may persist even after implementation of the system
- Capacity requirements of storm pumps at different pumping stations
- Flow rates and depth through different sections of the system, extent of surcharge or surface flooding
- System emptying time I.E.. the time required since recession of the rainfall event to evacuate entire storm runoff

#### **4.5.4 Proposed Storm Water Drainage System**

Storm water drains shall be provide on either side of the proposed road network of the area to collect the storm runoff generated from the catchment and get it discharged to the drainage channel for ultimate disposal to the sea.

Indicative command area (catchment area) for each of the existing drainage channels passing through BSMSN with locations of the pumping stations, proposed at the location close to its outfall to the sea is given in **Figures 4-20 and 4-21**.

While calculating the design flow rate through various drainage channels, due care shall be taken to consider

the contribution from the areas outside BSMSN. This requires detailed investigation for area outside BSMSN to ascertain the catchment area of the individual drainage channels. The extent of rehabilitation of the existing drainage channels to be finalised once catchment area is ascertained and expected design flow rate through the channels is established during the stage of detailed engineering design.

An assessment of storm runoff contribution from BSMSN and from areas outside BSMSN for individual drainage catchment areas has been made considering rainfall intensity of 34.4 mm/hr. and average runoff coefficient of 0.60 (keeping into consideration that rain water harvesting will be extensively practiced in BSMSN) for area within BSMSN and average runoff coefficient of 0.40 for area outside BSMSN and given in **Annexure 4.7**. The land area requirement for the different drainage pumping stations is also given in the same Annexure.

The size of the drains including capacity requirements of the pumping stations may undergo changes and to be finalized based on rainfall analysis findings and hydraulic modelling results. This is to be carried out during the stage of detail engineering design

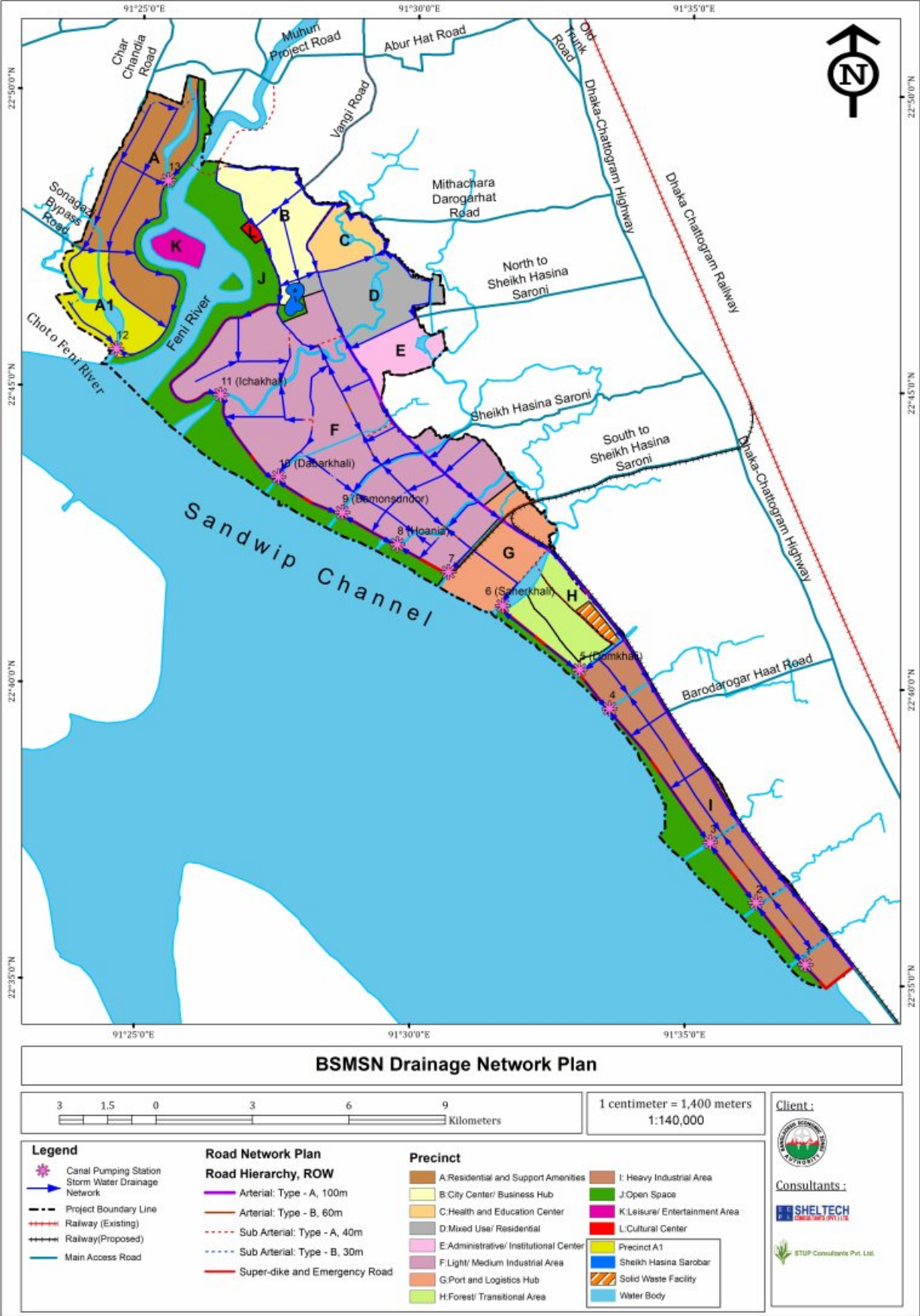

Figure 4-20: BSMSN Drainage Network Plan

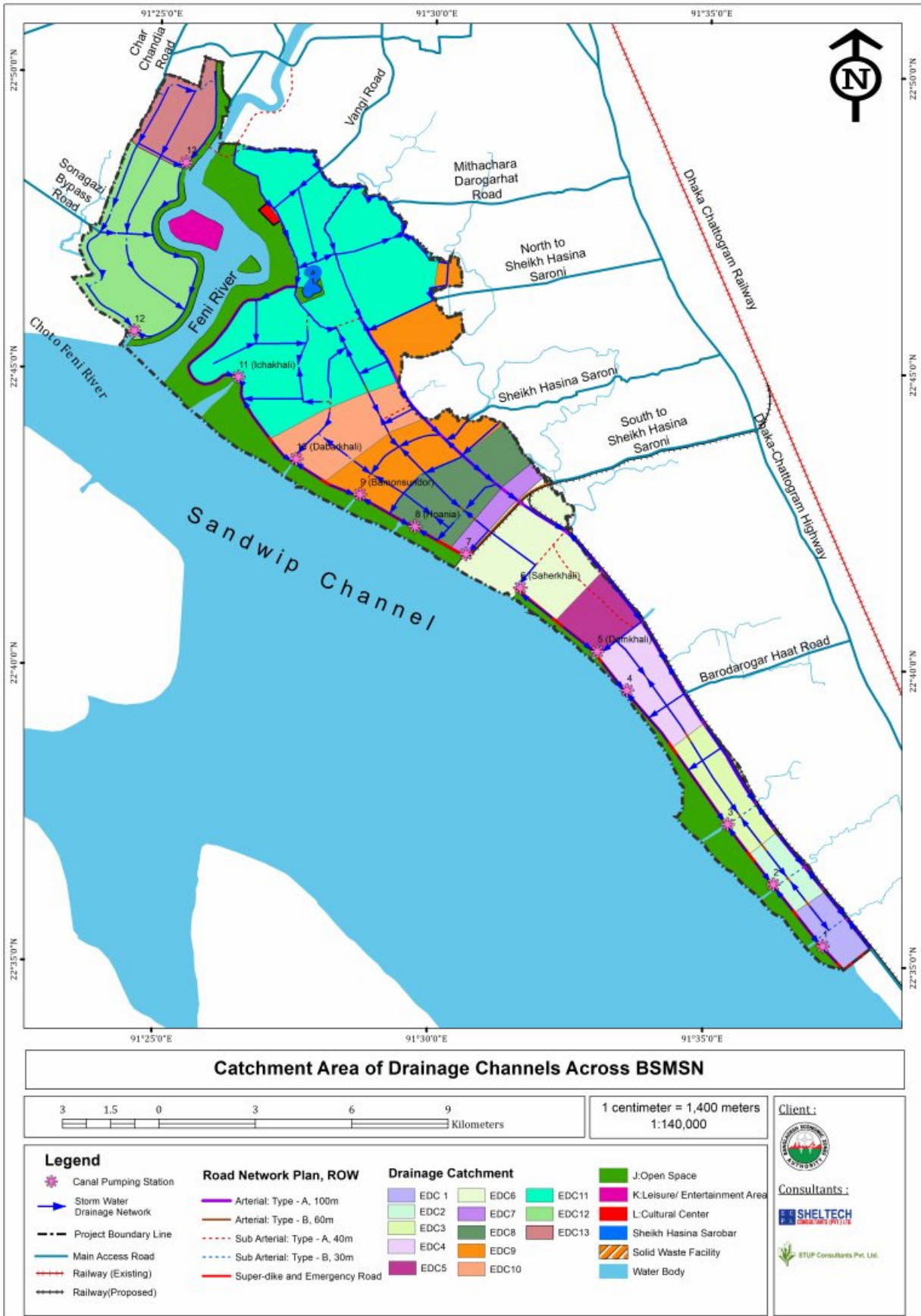

Figure 4-21: Catchment Area of Drainage Channels Across BSMSN

#### 4.5.5 Cost Estimations for the Storm Water Drainage System

##### a. Off-Site Infrastructure Costs

No cost on account for off-site development works is envisaged for the project. All the drainage channels passing through BSMSN originate from area outside. For deciding upon the sectional requirements of the drainage channels as well as pumping stations, contribution from the upstream areas been considered. The interventions, being in the upstream end, it is not mandatory to take-up the necessary development to accrue benefits to BSMSN. Same, if felt necessary, may be taken-up under a separate project.

##### b. On-Site Infrastructure Costs

The costs on account of storm water drainage system improvement measures is given in **Table 4-26** below.

Table 4-26: On-Site Infrastructure Cost for Storm Water Drainage System

Description of Item	Quantity / Units	Price Without Tax		Phase I Cost Breakdown (Years 1-5)		Phase II Cost Breakdown (Years 6-10)		Phase III Cost Breakdown (Years 11-15)	
		(In Million Taka)	(In Million USD)	(In Million Taka)	(In Million USD)	(In Million Taka)	(In Million USD)	(In Million Taka)	(In Million USD)
Trunk storm water drainage network	375 km	12750.0	150.0	3825.0	45.0	3825.0	45.0	5100.0	60.0
Storm water drain outfall structure with flap gate	85 nos.	722.5	8.5	212.5	2.5	221	2.6	289	3.4
Resectioning of existing natural drainage channels	48 km	11220.0	132.0	3366.0	39.6	3366.0	39.6	4488.0	52.8
Provision of sluice gates at outfall end of existing natural drainage channels	13 nos.	1105.0	13.0	552.5	6.5	552.5	6.5	-	-
Drainage pumping station	13 nos.	39363.5	463.1	19635.0	231.0	19728.5	232.1	-	-
Minor storm water drainage network	400 km	8500.0	100.0	2550.0	30.0	2550.0	30.0	3400.0	40.0
<b>Total</b>		<b>73661.0</b>	<b>866.6</b>	<b>30141.0</b>	<b>354.6</b>	<b>30243.0</b>	<b>355.8</b>	<b>13277.0</b>	<b>156.2</b>
Engineering Fees (5%)		3683.1	43.3	1507.1	17.7	1512.2	17.8	663.9	7.8
Contingency (15%)		11049.2	130.0	4521.2	53.2	4536.5	53.4	1991.6	23.4
Taxes (18%)		13259.0	156.0	5425.4	63.8	5443.7	64.0	2389.9	28.1
<b>On-Site Storm Water Drainage System Total</b>		<b>101652.3</b>	<b>1195.9</b>	<b>41594.7</b>	<b>489.3</b>	<b>41735.4</b>	<b>491.0</b>	<b>18322.4</b>	<b>215.5</b>

## 4.6 Domestic and Industrial Liquid Waste Handling System

### 4.6.1 Background Analysis

The different components of work associated with proposed domestic and industrial liquid waste handling system (sewerage system) include sewer network with allied appurtenant structures, sewage/ industrial effluent pumping station including pumping mains, sewage/ industrial effluent treatment plants including treated effluent disposal system. Design of facilities for the collection, treatment and disposal of liquid wastewater is dictated primarily by the estimated loadings to be handled. With respect to flow, both average and peak flow rates must be known in order to determine the required hydraulic capacities of sewers, pumping stations, sewage/ industrial effluent treatment plants and effluent disposal facilities. Similarly, strength and composition of the liquid waste (sewage) likely to be generated must be known in order to determine the degree and type of treatment required to produce an effluent of acceptable quality. In short, a study of waste volume and characteristics is necessary to develop the design criteria.

The design criteria for preparation of the sewerage system shall be generally in line with International standard practices.

### 4.6.2 Sewage Collection and Transportation System

#### a. Design Period

The project horizon is 2040. The development works for sewerage system shall be in conformity to phased development planning. The different components of the systems shall be sized and designed considering the following life cycles:

- Sewerage Network : For ultimate requirement upto 2040 AD in conformity to the phased development planning
- Pumping Station : Land for ultimate requirement I.E. upto 2040 AD  
Civil works and electro-mechanical works to suit modular development with adequate flexibility

#### b. Pipe Materials

- **For Sewers:** All sewers of size 800 mm or less shall be of unplasticized polyvinyl chloride (uPVC) of pressure rating not less than PN 6 (6 kg/cm<sup>2</sup>). Sewers of size exceeding 800 mm shall be of glass fibre reinforced plastic (GRP) pipe of pressure rating not less than PN 6 (6 kg/cm<sup>2</sup>)
- **For Pumping Mains:** Ductile iron of Class K9

#### c. Clearance to Other Services

Minimum clearances to be established to reduce the likelihood of damage to sewers or other services and to protect services and personnel during construction or maintenance work. Clearances provided to other services should preferably be maximized. The execution of design should be based on the actual location of those services. Recommended minimum clearances are as follows:

- **Parallel Services:** The minimum clear horizontal distance between the storm water drains and water lines shall be 1.0m
- **Sub-Surface Structures:** Horizontal clearance to structures such as valve pits, storm water sumps, hydrants etc. shall be 500 mm

- **Crossing Services:** The vertical distance of crossings between inverts of storm water drain or water lines and crown of sewers shall not be less than:
  - Storm water drains: 500 mm
  - Water mains: 1000 mm
  - Telecommunication cables: 300 mm; increased clearance might be required for coaxial cables
  - Low and medium pressure gas mains: 500 mm
  - High pressure gas mains: 750 mm
  - Electrical cables: 750 mm
  - In case minimum vertical clearance cannot be secured, both lines shall be concrete encased for a length of at least 3.0m on either side of the crossing.

#### 4.6.3 Domestic and Industrial Liquid Waste Handling System

The entire quantum of liquid waste (biological waste and/ or industrial waste, as the case may be) likely to be generated from BSMSN shall be catered to two sewage treatment plants (STPs) and four common effluent treatment plants (CETPs) aided by intermediate pumping stations. The prime purpose of providing the intermediate pumping stations is to restrict the depth of the sewers and also to facilitate crossing of the different natural drainage channels passing through BSMSN. Strategically the pumping stations shall be located in proximity to natural drainage channels to minimize the lengths of pumping mains. The different drainage channel crossings shall be affected by pipe supporting structures. In addition, terminal pumping stations shall be provided at location of all the treatment plants (STPs/ CETPs).

Considering the landuse characteristics, Precincts A, B, C, D, E and K will produce predominantly biological liquid waste I.E. where content of hazardous liquid wastes is insignificant. Precincts F and I are ear-marked for industrial use (light, medium and heavy). Precinct G is ear-marked for port and logistics. Such areas will produce industrial liquid wastes, with varied degree of toxicity. In addition, such areas will also produce biological liquid waste (generated from residential population accommodated within the zone). The pipe material suggested to be used (uPVC/ GRP) that are resistant to corrosion and the same pipeline may be used to cater the all types of flow generated from the industrial areas.

Quantum of biological liquid waste likely to be generated from industrial areas is not expected to exceed 5% of the quantum of industrial flow. As such, the combined flow generated from such areas is not likely to pose any functional problem to the CETPs to be constructed. Separate set of pipelines to carry industrial liquid waste and domestic liquid waste, as such, is not felt necessary.

**Figures 4-22 and 4-23** shows the sewerage system planning together with locations of different pumping stations (SPSs/ CEPs), their command areas and the treatment plants (STPs/ CETPs).

Salient details of the proposed liquid waste collection system and land area requirement for various installations are given in **Annexure 4.8**.

Location of each utility installation point has been selected as per the prescribed guidelines mentioned in Section 3.1 of Chapter 3.

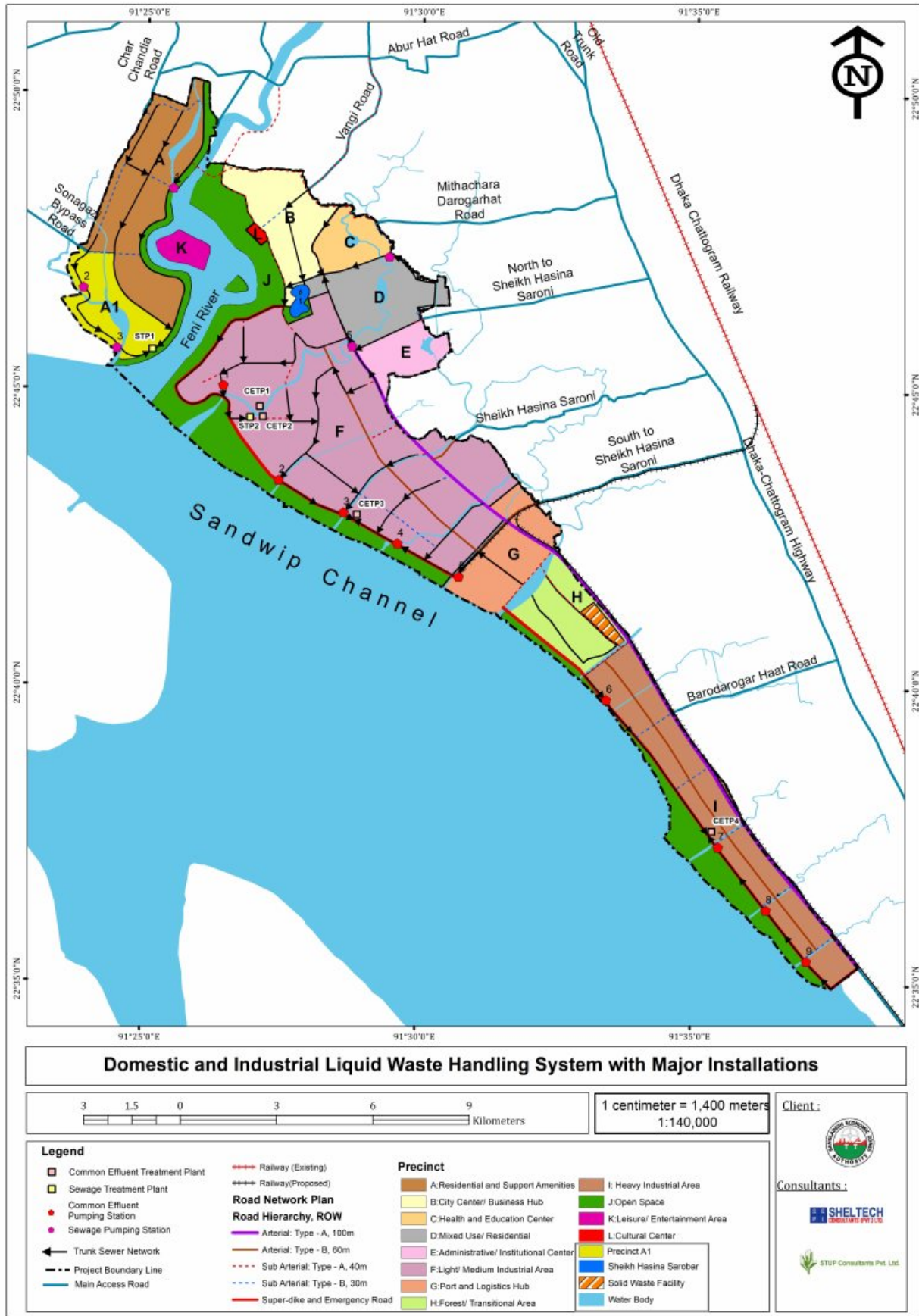

Figure 4-22: Domestic and Industrial Liquid Waste Handling System with Major Installations



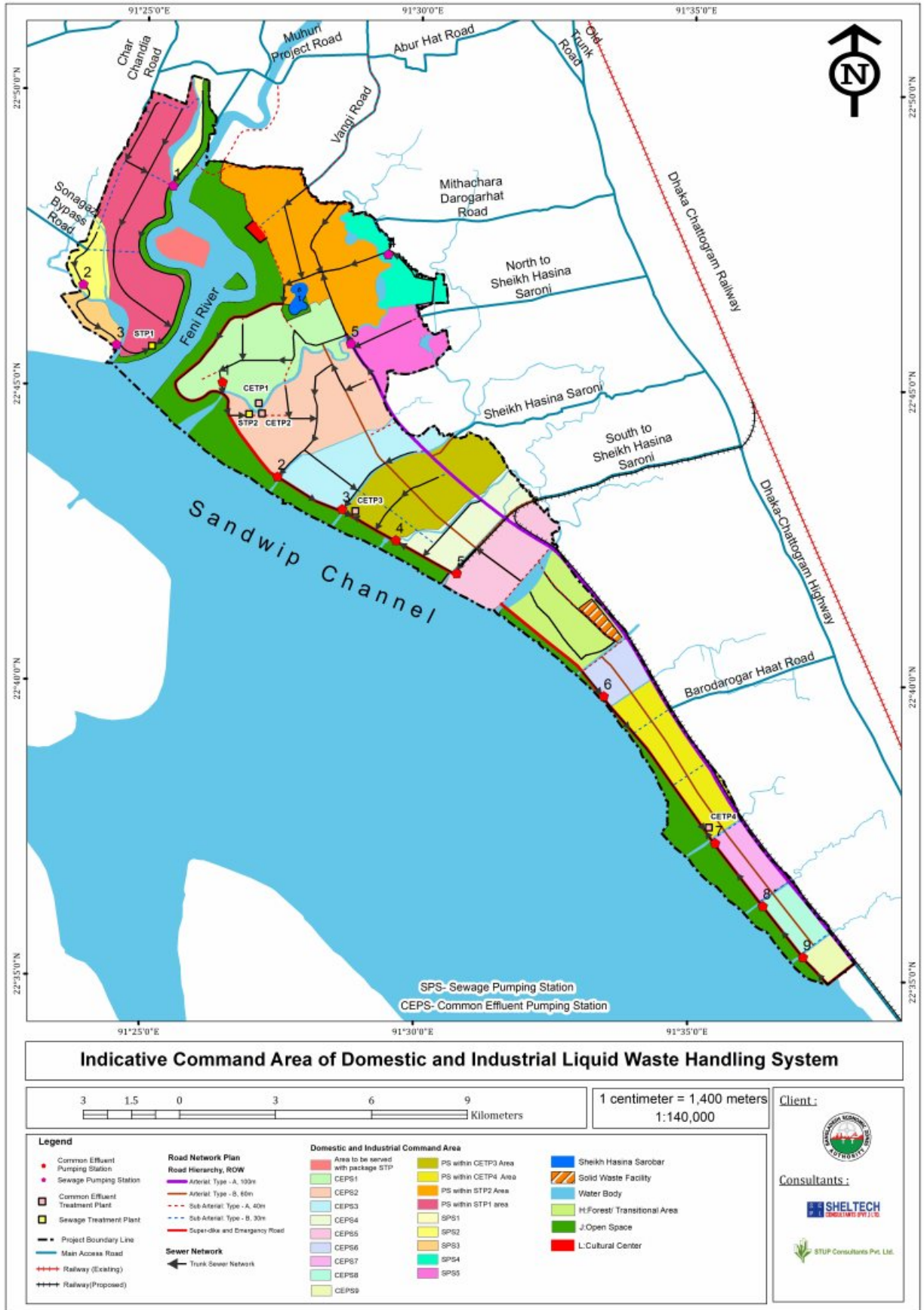

Figure 4-23: Indicative Command Area of Domestic and Industrial Liquid Waste Handling System

#### 4.6.4 Sewage Treatment Plant (STP)

Raw sewage generated from areas which produces predominantly biological liquid waste I.E. content of hazardous liquid wastes is in insignificant amount shall be treated using conventional biological treatment processes. The following areas within BSMSN will generate predominantly domestic raw sewage for which conventional treatment process is adequate and tertiary treatment processes to eliminate hazardous wastes is not felt necessary.

• <i>Precinct A:</i> Residential area	:	Comprises residential units together with small health clinics, schools, shopping centres, entertainment/leisure areas
• <i>Precinct B:</i> City centre/ business hub	:	Comprises commercial/ financial buildings
• <i>Precinct C:</i> Health and educational centre	:	Comprises hospitals, educational institutes, research and development facilities etc.
• <i>Precinct D:</i> Mixed use/ residential	:	Comprises residential and commercial usages
• <i>Precinct E:</i> Administrative/ institutional centre	:	Comprises administrative/ institutional centres, shopping/ retail area
• <i>Precinct K:</i> Leisure/ entertainment area	:	Comprises gathering spaces, marinas, restaurants, cafes, outdoor cinemas etc.

Of the above, sewage contribution from Precinct K is insignificant. Moreover, considering its location (an island) it is suggested to provide packaged treatment plant to handle the quantum of sewage generated from this area. A packaged treatment plant offers the user a pre-engineered and pre-fabricated method of treating wastewater with an aerobic process. The final effluent can be safely discharged to the river.

The raw sewage generated from the areas as mentioned above is predominantly (almost 99%) water carrying domestic wastes originating in kitchen, bathing, laundry, toilets etc. A portion of these goes into solution. The remaining goes into colloidal or suspended stages. It also contains salts used in cooking, sweat, bathing, laundry and human excreta. Waterborne pathogenic organisms from the human excreta of already infected persons are also present in raw sewage.

Sewage generated from other areas will contain predominantly hazardous chemical wastes with limited quantity of biological wastes and not suitable for treatment using conventional biological treatment process alone. Raw sewage generated from such areas is proposed to be taken to common effluent treatment plant (CETP) for treatment.

##### a. Design Period

The design period for sewage treatment plant (STP) is planned to meet the requirements upto project horizon of 2040. The development works for STP is planned taking into consideration the phased increment in demand. The different components of the systems shall be sized and designed considering the following life cycles:

- **Land:** for ultimate requirement I.E. upto 2040 AD
- **Civil Works and Electro-Mechanical Works:** to suit modular development with adequate flexibility

**b. Capacity Requirement for Sewage Treatment Plants**

Two Sewage Treatment Plants (STPs) are to be provided in the system, each with provision of modular development. Command area of the two STPs are:

- **STP 1:** to serve entire portion of Precinct A
- **STP 2:** to serve entire portion of Precincts B, C, D and E

Capacity requirement for the two STPs based on water demand assessment are as follows:

*Table 4-27: Capacity Requirements for the STPs*

STP	Estimated Sewage Flow (MLD)				Proposed STP Capacity (MLD)			
	2025	2030	2035	2040	2025	2030	2035	2040
1	13.680	19.680	28.560	41.760	15	20	30	45
2	25.070	36.070	52.360	76.560	25	40	55	80

STPs are potential source of pollution and adequate care is required to minimize the risk of environmental degradation. More the number of STPs proposed in a system, greater is the flexibility in operation of the system. Simultaneously this will increase the number of polluting sources. Also operating cost increases as the number of operating point increases. Two locations shall be ear-marked within the BSMSN for construction of STP, one on either side of Feni River. The STPs will be developed in a phased manner with modular approach of development. Length of sewer lines to carry the sewage generation is likely to be less if more number of STPs is provided. However, considering the benefit of having lesser number of STPs in long run, only two STPs are considered to be provided in the system.

**c. Recommended Quality Standard for Treated Effluent**

Recommended guidelines for treated sewage for discharge into surface water to be used as source of drinking water is as follows:

*Table 4-28: Recommended Quality Standards for Treated Effluent*

Parameters	Recommended Values
Biochemical oxygen demand, BOD <sub>5</sub> (mg/l)	Less than 10
Suspended solids (SS) (mg/l)	Less than 10
Total nitrogen (TN) (mg/l)	Less than 10
Dissolved phosphorous (mg/l)	Less than 2
Faecal coliform (MPN/100 ml)	Less than 230

**d. Sewage Treatment Plant Technology**

Of the different sewage treatment technologies available, *extended aeration (oxidation ditch)* system is suggested considering the degree of complexity, ease in operation and past performance record.

In this system sewage is treated in large aeration basins (large round or oval ditches) with one or more horizontal aerators which drive the mixed liquor around the ditch for aeration. Alternatively, air can be introduced to the sewage by bottom mounted diffusers driven by large

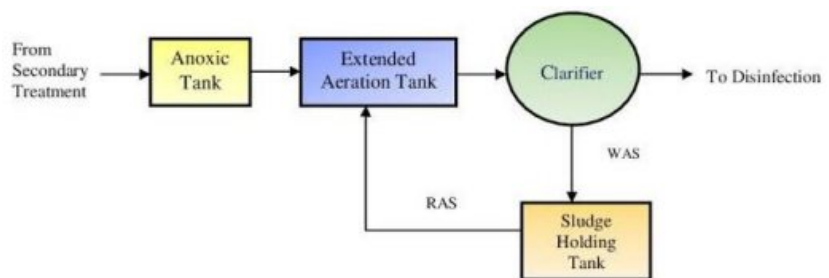

*Figure 4-24 Process Flow Diagram of Oxidation Ditch System*

compressors. Oxidation ditches have the advantage that they are relatively easy to maintain and are resilient to shock loads. Oxidation ditches have typical design parameters of a hydraulic retention time of 20 - 30 hours and a sludge age of 20 - 40 days. These systems are more robust and easier to operate and produce a sludge which is easy to digest from clarifiers located after the aeration basin.

*The choice of technology for wastewater treatment plant might also be done by a design build process where Contractors are given the required effluent discharge parameters viz. BOD<sub>5</sub>, TSS etc. and are invited to come up with the proposed technology and design of a system to meet the required effluent standards at the lowest life cycle cost considering capital and operating cost.*

**e. Sludge Treatment**

Sewage sludge is the solid, semi-solid, or slurry residual material that is produced as a by-product of wastewater treatment processes. This residue is commonly classified as primary and secondary sludge. Primary sludge is generated from chemical precipitation, sedimentation, and other primary processes, whereas secondary sludge is the activated waste biomass resulting from biological treatments. The two type of sludge will be combined together for further treatment and disposal.

Two basic goals of treating sludge before final disposal are to reduce its volume and to stabilize the organic materials. Stabilized sludge does not have an offensive odor and can be handled without causing a nuisance or health hazard. Smaller sludge volume reduces the costs of pumping and storage.

Treatment of sewage sludge will include a combination of thickening, digestion, and dewatering processes.

Thickening is the first step in sludge treatment because it is impractical to handle thin sludge, a slurry of solids suspended in water and will be accomplished by dissolved-air flotation method. In this method, air bubbles carry the solids to the surface, where a layer of thickened sludge forms.

Sludge digestion is a biological process in which organic solids are decomposed into stable substances. Digestion reduces the total mass of solids, destroys pathogens, and makes it easier to dewater or dry the sludge. Digested sludge is non-offensive, having the appearance and characteristics of a rich potting soil. The nutrient rich bio-solids may be used as a natural fertilizer.

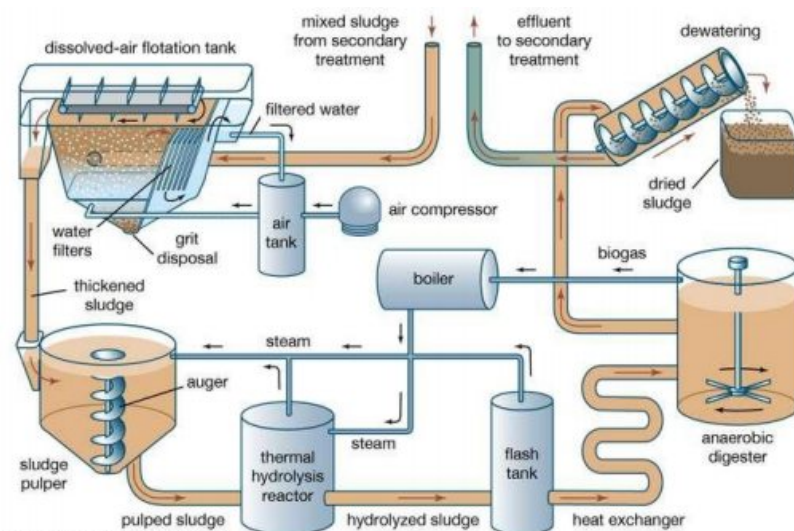

Figure 4-25: Process Flow Diagram for Sludge Treatment

**f. Reuse of Treated Water**

Initially a portion of treated effluent (say 20%) may be reused with minimum chlorination for street washing and later effort may be made to recycle maximum quantum of treated wastewater for various purposes including industrial usages. The local body shall have to make necessary arrangement for

transportation of this water from STP sites to designated locations. For this a separate pipeline is to be planned along with installation of hydrants at various locations.

**g. Plant Operation Philosophy**

The entire sewage treatment plant shall be fully automated with state-of-the-art technology, comprising of PLC and SCADA based controls. The connection shall be on fiber-optics made. History of data shall be stored and analysed for process optimization and real time process control. Alarm history and flow trends shall be part of SCADA operation. Operator shall come to know and diagnose the fault occurring due to sensor failure or pump tripping. Sewage treatment plant shall be equipped with Supervisory Control and Data Acquisition (SCADA) system. SCADA system shall present the data as a viewable and controllable system on the screen of a computer. It is suggested to prepare and store data on daily, weekly and monthly basis.

**h. Land Area Requirements for Construction of Sewage Treatment Plant**

*Table 4-29: Land Area Requirements for Construction of Sewage Treatment Plants*

Unit	Capacity Requirement at Ultimate Stage (2040)	Land Area Requirements
STP 1	45 MLD	7.0 ha (17 acres)
STP 2	80 MLD	12.5 ha (31 acres)
<b>Total land area required</b>		<b>19.5 ha (48 acres)</b>

Suitable locations shall be ear-marked within the BSMSN for construction of STP, one on either side of Feni River. Indicative location of the STPs is shown in the figures given above for sewerage system. The location, as shown may undergo changes depending on micro-level landuse planning of the area.

**4.6.5 Common Effluent Treatment Plant (CETP)**

Effluent treatment plant (ETP) is one type of wastewater treatment method which is particularly designed to purify industrial wastewater for its reuse and its aim is to release safe water to environment from the harmful effect caused by the effluent.

Composition of industrial effluent varies widely depending on the type of industry. Some effluents contain oils and grease, and some contain toxic materials (I.E. cyanide, heavy metals). Effluents from food and beverage factories contain degradable organic pollutants. Since industrial wastewater contains a diversity of impurities, specific treatment technology, called ETP is required.

The ETP plant works at various levels and involves various physical, chemical, biological and membrane processes to treat wastewater from different industrial sectors.

Collective treatment at a centralized location, known as CETP is a viable treatment solution, to overcome the constraints associated with effluent treatment from industries with varied quality of effluent.

The concept of CETP is to achieve a way to ensure end-of-the-pipe treatment of combined wastewater to avail the benefit of scale of operation. In addition, CETP will facilitate in reduction of number of discharge points in an industrial area for better enforcement and also to make available skilled man-power for proper treatment of effluent.

Precincts F and I are ear-marked for industrial use (light, medium and heavy). Precinct G is ear-marked for port and logistics. Such areas are likely to produce industrial liquid wastes, with varied degree of toxicity. In addition, such areas are likely to produce biological liquid waste also (from industrial workers + residents of the area). Sewage generated from such areas will not be suitable for treatment using conventional biological treatment process alone. Raw sewage generated from such areas is proposed to be taken to common effluent treatment plant (CETP) for treatment.

**a. Design Period**

The design period for common effluent treatment plant (CETP) is planned to meet the requirements upto project horizon of 2040. The development works for CETP is planned taking into consideration phased increment in demand. The different components of the systems shall be sized and designed considering the following life cycles:

- **Land:** for ultimate requirement I.E. upto 2040 AD
- **Civil Works and Electro-Mechanical Works:** to suit modular development with adequate flexibility

**b. Capacity Requirement for Common Effluent Treatment Plants**

Four common effluent treatment plants (CETPs) are to be provided in the system, each with provisions of modular development. The command area of the four CETPs are:

- **CETP 1:** to serve portion of Precinct F (zones 2A and 2B)
- **CETP 2:** to serve portion of Precinct F (zones 2A, 2B, 3 and 5)
- **CETP 3:** to serve entire portion of Precinct G and portion of Precinct F
- **CETP 4:** to serve entire portion of Precinct I

Capacity requirements of the CETPs are assessed based on the following considerations:

- 80% of the net water demand of the users (industrial/ residential) will come out of the system as liquid wastewater
- 15% of the domestic wastewater generation per day will be generated from the area ear-marked for industrial usages (considering that either they will live in the industrial area or will be industrial workers)

Capacity requirements for the four CETPs based on the water demand assessment and above considerations, are as follows:

*Table 4-30: Capacity Requirements for the CETPs*

CETP #	Estimated Sewage Flow (MLD)				Proposed STP Capacity (MLD)			
	2025	2030	2035	2040	2025	2030	2035	2040
1	16	16	16	16	16	16	16	16
2	32	32	32	32	32	32	32	32
3	52.51	73.21	103.09	144.85	30	75	105	150
4	133.35	185.86	261.65	367.54	50	190	270	370

CETPs are potential source of pollution and adequate care needs to be provided to minimize the risk of environmental degradation. More the number of CETPs proposed in a system, greater is flexibility in operating the system. Simultaneously, with increase in number of CETPs, the number of polluting points increases. Also operating cost increases as the number of operating point increases. Four locations within the BSMSN shall be ear-marked for construction of CETP, three for small and medium scale industries and port area (precincts F and G); the other for heavy industries (precinct I). Of the three CETPs required in Precinct F, two CETPs (CETP 1 and CETP 2) are going to be constructed to meet the requirements for zones 2A and 2B as priority works. The other two CETPs (CETP 3 and CETP 4) are suggested to be developed in

a phased manner with modular approach of development. Suitable modification in the technology of treatment for each module may be made depending on the characteristics of sewage flow for individual streams. Length of sewer lines to carry the industrial/ domestic sewage generation is likely to be less if more number of CETPs is provided. However, considering the benefit of having lesser number of CETPs in long run, only four CETPs (including the 2 CETPs to be constructed under priority works) are proposed to be provided in the system.

**c. Recommended Influent and Treated Effluent Quality Standards for CETP**

To ensure consistency in influent quality all the industries need to send only those effluents, which can be treated at the CETP. For this, pre-treatment facility for individual industries will be required to ensure that the quality of effluent reaching to the CETP fulfils the quality criteria. In case of heterogeneous industrial complexes, pre-treatment is a more reliable relief in operation and maintenance (OandM) of CETP. All industries shall be asked to send effluents to the CETP only after pre-treatment. This will also reduce the risk of corrosion and clogging to the gravity sewers carrying flow to the CETP. Efficiency of the biological treatment process in the CETP will simultaneously increase due to lesser toxic constituents.

Table 4-31: Proposed Inlet Effluent Quality Standards for CETP

Parameters	Concentration	Parameters	Concentration
pH	5.5-9.0	Zinc (mg/l)	15.0
Temperature (°C)	45.0	Lead (mg/l)	1.0
Oil and grease (mg/l)	20.0	Arsenic (mg/l)	0.2
Cyanide (as CN) (mg/l)	2.0	Mercury (mg/l)	0.01
NH <sub>3</sub> -N (as N) (mg/l)	50.0	Cadmium (mg/l)	1.0
Phenolic compounds (as C <sub>6</sub> H <sub>5</sub> OH) (mg/l)	5.0	Selenium (mg/l)	0.05
		Fluoride (mg/l)	15.0
Hexavalent chromium (mg/l)	2.0	Boron (mg/l)	2.0
Total chromium (mg/l)	2.0	Radioactive materials	
Copper (mg/l)	3.0	- Alpha emitters (He/ml)	10 <sup>-7</sup>
Nickel (mg/l)	3.0	- Beta emitters (He/ml)	10 <sup>-8</sup>
BOD <sub>5</sub> (mg/l)	600	COD (mg/l)	1260
TDS (mg/l)	2100		

Table 4-32: Recommended Treated Effluent Quality Standard for CETP

Parameter	Into Inland Surface Water	On Land for Irrigation	Into Marine Coastal Areas	For Reuse
pH	5.5-9.0	5.5-9.0	5.5-9.0	6.0-9.0
BOD <sub>5</sub> at 20 °C (mg/l)	30	100	100	10
Oil and Grease (mg/l)	10	10	20	10
Temperature (°C)	≤ 40	-	45	a) summer - 40 b) winter - 45
Suspended Solids (mg/l)	100	200	a) for process wastewater - 100	100
			b) for cooling water effluents - 10% above total suspended matter of effluent	
Dissolved Solids (inorganic) (mg/l)	2100	2100	-	2100
Total Residual Chlorine	1.0	-	1.0	
Ammonia (as free ammonia) (mg/l)	-	-	-	5.0
NH <sub>3</sub> -N (as N) (mg/l)	50	-	50	40
Total Kjeldahl Nitrogen (as N) (mg/l)	100	-	100	100

Parameter	Into Inland Surface Water	On Land for Irrigation	Into Marine Coastal Areas	For Reuse
COD (mg/l)	250	-	250	50
Arsenic (mg/l)	0.2	0.2	0.2	0.2
Mercury (mg/l)	0.01	-	0.01	0.01
Lead (mg/l)	0.1	-	0.1	0.1
Cadmium (mg/l)	1.0	-	2.0	2.0
Total Chromium (mg/l)	2.0	-	2.0	0.5
Chromium (as Cr <sup>+6</sup> ) (mg/l)	-	-	-	0.5
Copper (mg/l)	3.0	-	3.0	0.5
Zinc (mg/l)	5.0	-	15.0	5.0
Iron (mg/l)	-	-	-	2.0
Manganese (mg/l)	-	-	-	2.0
Selenium (mg/l)	0.05	-	0.05	0.05
Nickel (mg/l)	3.0	-	5.0	1.0
Boron (mg/l)	2.0	2.0	-	2.0
% sodium (mg/l)	-	60	-	
Cyanide (as CN) (mg/l)	0.2	0.2	0.2	0.1
Chloride (as Cl) (mg/l)	1000	600	-	600
Fluoride (mg/l)	2.0	-	15.0	2.0
Sulphate (as SO <sub>4</sub> ) (mg/l)	1000	1000	-	-
Sulphide (as S) (mg/l)	2.8	-	5.0	1.0
Nitrate (as elementary N) (mg/l)	-	-	-	10.0
Pesticides	Absent	Absent	Absent	
Phenolic compounds (as C <sub>6</sub> H <sub>5</sub> OH) (mg/l)	1.0	-	5.0	1.0
Dissolved Oxygen (DO) (mg/l)	-	-	-	4.5-8.0
Dissolved Phosphorus (as P) (mg/l)	-	-	-	4.0
Electro-Conductivity (EC) (µmho/cm)	-	-	-	1200

**d. Technology for Common Effluent Treatment Plants**

The choice of technology for common effluent treatment plant shall be done by a design build process where Contractors will be given the required effluent discharge parameters viz. BOD<sub>5</sub>, TSS etc. and will be invited to come up with the proposed technology and design of a system to meet the required effluent standards at the lowest life cycle cost considering capital and operating cost.

**e. Sludge Treatment**

Utilization of CETP sludge for agricultural use is acceptable, provided it is free from hazardous constituents. The primary sludge, in general, due to its constituents, falls under the purview of regulatory provisions for proper disposal into treatment storage disposal facility (TSDF). The secondary sludge from biological treatment predominantly contains nutrients. This can be utilized as manure, especially for dry land or forest disposal at controlled rates. Both primary and secondary sludge will be dewatered to reduce the amount of sludge. Any sludge that may still contain hazardous material will be disposed in proper TSDF, after required analysis.

**f. Reuse of Treated Water**

Wastewater after treatment will be recycled to meet various industrial water usages (viz. steel plant) as well as other usages to meet non-domestic demand including gardening, cleaning, car washing etc. Effort shall be given to recycle about 70% of the wastewater after treatment to meet various industrial usages. This in turn will substantially reduce the quantum of water to be drawn from various sources to meet the water demand



of BSMSN. A separate pipeline is to be planned along with installation of hydrants at various locations to carry the recycled wastewater.

**g. Land Area Requirements for the Construction of CETPs**

*Table 4-33: Land Area Requirements Construction of Common Effluent Treatment Plants*

Unit	Capacity Requirement at Ultimate Stage (2040)	Land Area Requirement	Locations
CETP 1	16 MLD	18 acres	Within Precinct F
CETP 2	32 MLD		Within Precinct F
CETP 3	150 MLD	60 acres	Within Precinct F
CETP 4	370 MLD	80 acres	Within Precinct I
<b>Total land area required</b>		<b>158 acres</b>	

Locations of CETPs 1 and 2 are already finalized within BSMSN. Same is shown in the figure given for sewerage system. Indicative location of the other two CETPs is shown in the figure given for sewerage system. The location, as shown may undergo changes depending on micro-level landuse planning of the area.

**4.6.6 Cost Estimation of Sewerage System**

**a. Off-Site Infrastructure Costs**

No cost on account of off-site development works is envisaged for the project since all the interventions required for development of sewerage system improvement measures will be located within the BSMSN.

**b. On-Site Infrastructure Costs**

The costs of a sewerage in BSMSN is outlined in Table 4-34 below:

*Table 4-34 On-Site Infrastructure Cost for Liquid Waste Handling System*

Description of Item	Quantity/ Unit	Price Without Tax		Phase I Cost Breakdown (Years 1-5)		Phase II Cost Breakdown (Years 6-10)		Phase III Cost Breakdown (Years 11-15)	
		(In Million Taka)	(In Million USD)	(In Million Taka)	(In Million USD)	(In Million Taka)	(In Million USD)	(In Million Taka)	(In Million USD)
Sewerage network	400 km	37017.5	435.5	12129.5	142.7	12979.5	152.7	11908.5	140.1
Sewage Pumping Station (SPS) including pumping main	7 nos.	1850.9	21.8	606.5	7.1	649.0	7.7	595.4	7.0
Common effluent pumping station (CEPS) including pumping main	11 nos.	5552.6	65.3	1819.4	21.4	1946.9	22.9	1786.3	21.0
Sewage treatment plant (STP)	2 nos.	6663.2	78.4	2183.3	25.7	2336.3	27.5	2143.5	25.2
Common effluent treatment plant (CETP)	4 nos.	51084.2	601.0	16738.7	196.9	17911.7	210.8	16433.7	193.3
<b>Total</b>		<b>37017.5</b>	<b>435.5</b>	<b>12129.5</b>	<b>142.7</b>	<b>12979.5</b>	<b>152.7</b>	<b>11908.5</b>	<b>140.1</b>
Engineering Fees		1850.9	21.8	606.5	7.1	649.0	7.7	595.4	7.0

Description of Item	Quantity/ Unit	Price Without Tax		Phase I Cost Breakdown (Years 1-5)		Phase II Cost Breakdown (Years 6-10)		Phase III Cost Breakdown (Years 11-15)	
		(In Million Taka)	(In Million USD)	(In Million Taka)	(In Million USD)	(In Million Taka)	(In Million USD)	(In Million Taka)	(In Million USD)
(5%)									
Contingency (15%)		5552.6	65.3	1819.4	21.4	1946.9	22.9	1786.3	21.0
Taxes (18%)		6663.2	78.4	2183.3	25.7	2336.3	27.5	2143.5	25.2
<b>On-Site Liquid Waste Handling System Total</b>		<b>51084.2</b>	<b>601.0</b>	<b>16738.7</b>	<b>196.9</b>	<b>17911.7</b>	<b>210.8</b>	<b>16433.7</b>	<b>193.3</b>

## 4.7 Telecommunication Network

### 4.7.1 Overview

Telecommunications and associated applications have long been recognized as key enablers of the three dimensions of sustainable development-economic growth, environmental balance and social inclusion. Bangladesh Telecommunication Regulatory Commission (BTRC) has been functioning to regulate the activities of Telecommunication and Internet Service Providers.

In Bangladesh, both, landline and mobile phone networks, are available. Landline facilities including connections and maintenance are done by BTCL (Bangladesh Telecommunications Company Ltd.). At present no landline communication is available at the site or its immediate surroundings.

There are 5 mobile phone operators in Bangladesh, operating under the names of Airtel, Banglalink, Grameenphone, Robi and TeleTalk. The BSMSN area has 3G internet coverage of Grameenphone and 4G coverage of Robi, two leading operators in Bangladesh. Both these companies have voice call availability at the site.

BTCL and Power Grid Company of Bangladesh (PGCB) have their optical fiber networks in the country. BTCL has copper, optical fiber and microwave networks almost all over the country. Transmission backbone among exchanges consists of optical and microwave network. PGCB has installed OPGW (Optical Ground Wire) on high voltage transmission line (National Power Grid) to protect the transmission lines from thundering. The length of the OPGW installed in the transmission line of PGCB till June 2012 was approximately 4300 km and covering the major parts of the country. After PGCB's own communication need, the spare optical fibers capacities are leased out to local telecom operators for their commercial use. **Figure 4-26** shows the optical fiber network of BTCL. BTCL is working on a project to extend landline facilities to the project area including OFC connection. PGCB is going to establish a 400-kVA substation in the Project area at a later stage. With the 400-kV national grid network the site will be connected by PGCB OPGW 48 fiber OFC network. It will be a good future option for telecommunication for the BSMSN.

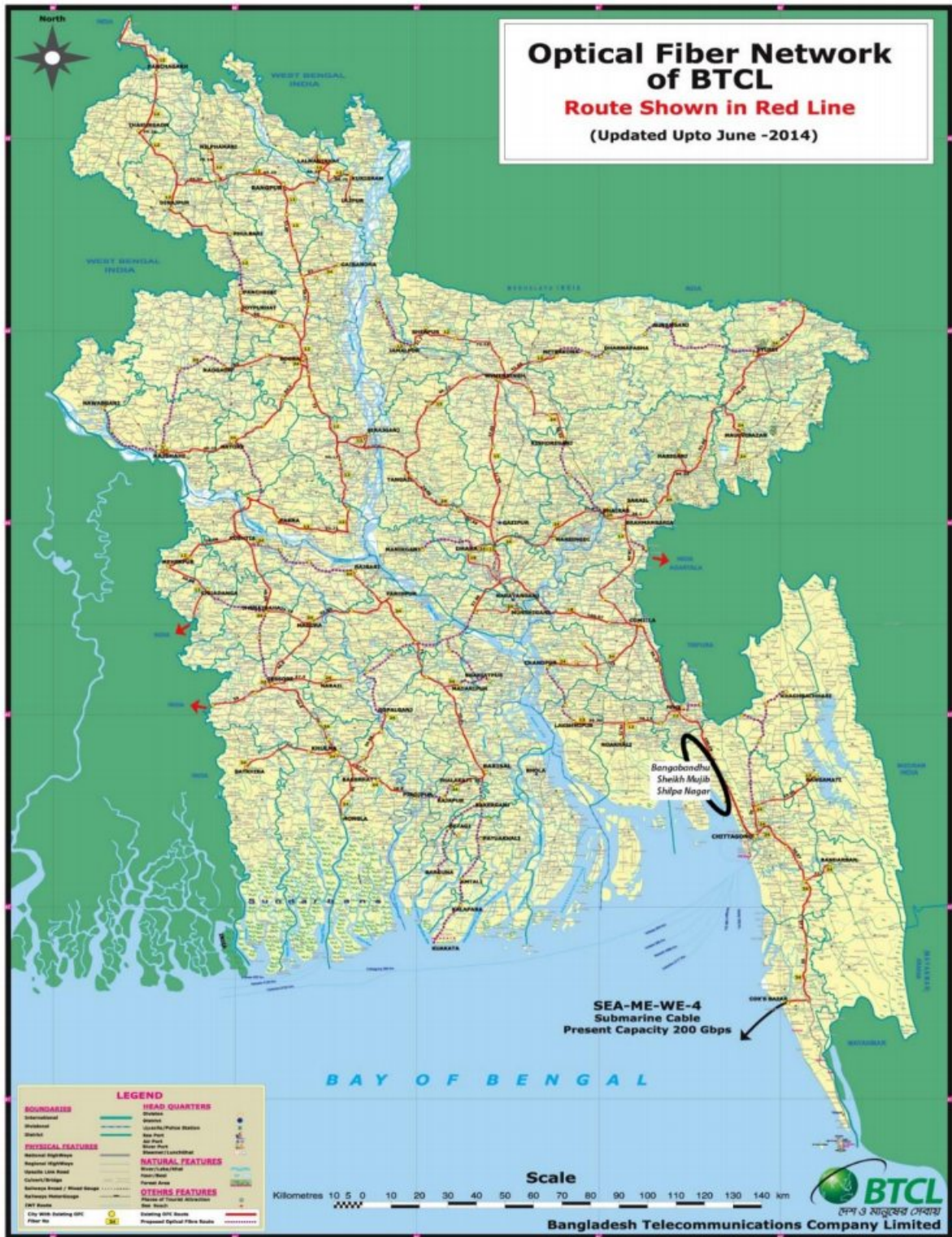

Figure 4-26: Optical Fiber Network of BTCL

#### 4.7.2 Future Direction

Telecommunications is an emerging sector that has significantly changed the way to communicate, work, and commute. The planned concentration of industry, business and population of BSMSN offers the tremendous opportunity to provide an integrated network serving as the regional hub for public and private users. A networked, integrated telecommunications system that will capitalize the potential of BSMSN as an IT hub and will be capable of providing advanced information services, which will be produced by public and private providers located within the City, to all inhabitants of the city and beyond.

Telecommunication infrastructure is required to support growth and underpin BSMSN's national and international significance. BSMSN will take step to ensure infrastructure provision is incorporated into wider agency planning and budgets, so that elements like telecommunications are in place to meet industry needs. However, following directive measures will be considered to make the BSMSN as Smart City during the development of Telecommunication infrastructure:

- Telecommunications system will be regulated in such way that it can ensure and safeguard the public interest of BSMSN.
- An integrated information telecommunications infrastructure system will be created using existing and privately and publicly-owned networks and systems as a base for growth.
- Expanded and improved delivery of advanced telecommunications services will be provided to stimulate economic growth and development in BSMSN.
- To ensure that the BSMSN implements state-of-the-art telecommunications technology, consistent with current and future requirements and economic conditions.
- Support the special needs of urban emergency and public safety services and benefit the largest number of people.
- Encourage the development of a wide variety of public and private telecommunications services available to all City residents and businesses.
- Improvement of the existing emergency telecommunications systems so that it can better respond to and mitigate the impacts of various emergency situations.
- Encourage use of renewable energy sources to create green telecommunication sector.
- Promote, enhance and continue adoption of environment-friendly activities in telecommunications arena in BSMSN.
- Facilitate high speed broadband services for all individuals, communities, educational institutions, homes, industry, and businesses hub in the BSMSN.

## 4.8 BSMSN Plantation Plan

There are a number of ways to make green BSMSN in order to create pleasant environments, which are sustainable and resilient to climate change. Some options are presented below:

### 4.8.1 Green Streets: The Core Concept

Planting trees along the street edge to create a 'Green Street' is important to enhance both the traffic and pedestrian experience. A green street or green Infrastructure (GI) can be defined as combination of natural and human-made elements that provide ecological and hydrological functions and processes etc. Green Streets help to build a city that is resilient to climate change and contributes to an improved quality of life.

### 4.8.2 Benefits of Plantation/Green Streets

A variety of trees and vegetation will be systematically and strategically planted throughout BSMSN to provide climate and environmental protection and make BSMSN resilient to climate change, This will be done by:

- Enhancing the extent and longevity of the urban forest/mangroves created
- Mitigating urban heat island effects
- Managing stormwater runoff to mitigate flooding and enhance water quality
- Promoting infiltration to sustain shallow groundwater systems and maintain interflow patterns
- Enhancing air quality
- Conserving / generating energy
- Providing recreational and breathing place for the inhabitants
- Restoring biodiversity in the zone
- Providing eco-friendly walking paths as well as creating aesthetic and scenic beauty within BSMSN
- Creating a balance between environment, human life and livelihood
- Prevention of noise pollution

### 4.8.3 Options for Creating Green Streets

#### a. Urban Forest Canopy

The natural (urban) tree canopy is composed of all layers, leaves, branches and stems that cover the ground. Tree canopy performs critical ecological functions within the urban environment such as managing stormwater; reducing the urban heat island effect, air pollution and providing wildlife habitat. Enhanced tree canopy also has an aesthetic value, improves quality of life and increases property values. Tree planting is appropriate within all street types with the exception of residential and mixed-use roads where large canopy native species are preferred to be planted. This tree canopy can be provided within Precinct H, K and along the Bay of Bengal and the Feni River waterfronts.

#### b. Native Herbaceous Planting

Native herbaceous plants are indigenous to Bangladesh and are characterized by their lack of woody stems above ground level. Herbaceous plant material can be integrated into a variety of green infrastructure (GI) options to promote pollinator habitat and enhance biodiversity within the streets. Plant material should

not only be selected for its aesthetic quality and habitat value, but also for its tolerance of drought and urban conditions. This type of planting should be promoted throughout BSMSN.

#### **c. Street Trees**

Street trees can be planted in hard or soft landscape conditions within all precincts within BSMSN. Street trees help to improve the overall living/working environment and can assist in improving air quality and reducing the urban heat. Preferences should be given for large canopy native species for street tree planting, which are low maintenance. IE. Some fruit trees grow fruit, create sticky substances or drop leaves which creates hazardous situations in urban environments.

#### **d. Green Walls**

A series of green walls/fences can provide valuable green infrastructure within confined urban/industrial spaces. Green walls can feature plants rooted in the ground and trained to grow up a vertical wall, known as a 'green facade' or plants that are rooted in a vertical modular, composite or custom substrate system that is affixed directly to an existing structural wall, known as a 'living wall'.

Green walls can be applied to bridge abutments within any street type. It can also be applied as noise barriers along street corridors to assist with noise attenuation. Providing green wall systems and the appropriate plant materials will be critically important to enhancing BSMSN environment.

#### **e. Trees in Soil Cells**

Soil cell systems can be used within BSMSN when street trees are desirable in locations where surface areas are limited. Soil cells are rigid modular systems that increase the soil volume under paved surfaces in ultra-urban areas. They provide the structural integrity required to support vehicular load on paved surfaces while offering highest level of porous space in order to accommodate underground services and utilities. These can be used throughout BSMSN.

#### **f. Trees in Open Planters**

Open tree planters can be used in many areas of BSMSN, though most likely in Precincts A, B, C, D, E, K, and L or where people will be gathering in open spaces or piazzas/squares. Tree planters are able to accommodate two or more trees per planter and can be framed by a low curb or higher seat wall. Open tree planters are typically the most cost-effective way to plant in a hard landscape if space allows, but are not the preferred solution in areas with high volumes of pedestrian traffic. The soil volume can also be augmented by installing soil cells below the grade of the planter.

### **4.8.4 Plantation Along with Roads, Railway and Natural Channels**

A comprehensive plantation plan has been proposed along the road and rail networks, natural water channels, coastal area along the Bay of Bengal and the Feni River, open spaces, and in Precincts K and L of the BSMSN Master Plan.

#### **a. List of Trees for Planting within BSMSN**

By planting environmentally friendly local plants, it is possible to enhance the environment and biodiversity for local birds and animals, as well as for the various other local inhabitants living in BSMSN. It is important however, to place the right type of tree in the correct environment for it to flourish. Maintenance of trees and vegetation should always be considered, when preparing a plantation plan. The following are a list of local trees to be considered for plantation in BSMSN:

Table 4-35: List of Trees to be Considered Within BSMSN

Arbor	Shrub	Herbaceous	Medicinal
Peacock (Caesalpinia pulcherrima)	Jungle geranium (Ixora coccinea)	Marigold (Tagetes erecta)	Arjun (Terminalia arjuna)
Royal poinciana (Delonix regia)	Orchid (Bauhinia variegata)	Rose Periwinkle (Catharanthus roseus)	Beleric (Terminalia bellirica)
Golden shower (Cassia fistula)		Garden Croton (Codiaeum variegatum)	Neem (Azadirachta indica)
Indian rose chestnut (Mesua ferrea)		Holy Basil (Ocimum tenuiflorum)	
Ashoka (Saraca asoca)		Indian Heliotrope (Heliotropium indicum)	
Bombax (Bombax ceiba)		Green Chiretta (Andrographis paniculata)	
Asian Palmyra Palm (Borassus flabellifer)			
Camel's Foot (Bauhinia purpurea)			
Spanish Cherry (Mimusops elengi)			
Blackboard (Alstonia scholaris)			
Burflower (Neolamarckia cadamba)			
Mandara (Erythrina variegata)			
Lebbeck (Albizia lebbeck)			
Niger (Rhizophora apiculata)			
Banyan (Ficus benghalensis)			

**b. Specific Plantation Guidelines for Precinct J**

Precinct J contains lands along the Bay of Bengal to the super dyke. This area has been reserved for open space and is to remain mainly as a forest of mangroves. This area will act as a prime barrier to any future cyclonic storms and will keep BSMSN resilient and protected from climate change calamities

This site should be planted according to the coastal afforestation guidelines. According to FAO’s ‘Coastal Forest Rehabilitation Manual’, the number of trees per hectare can vary greatly between different planting densities. For example, planting trees at 0.5 x 0.5 m spacing requires 40,000 trees per hectare, while at 1 x 1 m spacing 10,000 trees are required and at 1 x 2 m only 5,000 trees are required. The spacing of trees has been determined by the typology of mangrove trees. Choice of spacing of trees has been determined by the canopy coverage of mangrove trees. Tree having larger canopy coverage requires more spacing.

This plantation will provide multiple climatic advantages for the city, such as:

- Conservation of mangrove forest
- Minimize effect of climate change
- Protect BSMSN site from cyclonic storm
- Protect the site from erosion
- Biodiversity restoration
- Allow linear parkland for active and passive experiences
- Create a positive effect on the microclimate

- Control temperature for BSMSN

**c. List of Trees for Precinct J**

There is an opportunity to create a very important green environment along the coastline of BSMSN as long as it is comprehensively planned and implemented in phases. The area should be a mix of forest and mangroves to support biodiversity and flora/fauna in the region as well as provide a series of linear park spaces (both active and passive) for BSMSN residents, investors, workers, and visitors. This Coastal Green Plan should be designed by BEZA and approved by the Bangladesh Forest Department. It should also follow coastal afforestation guidelines of Food and Agriculture Organization (FAO) and International Union for Conservation of Nature (IUCN). Some of the preferred local species for this Precinct are:

Common Name	Scientific Name
Sundari	<i>Heritiera fomes</i>
Gewa	<i>Excoecaria agallocha</i>
Passur	<i>Xylocarpus mekongensis</i>
Dhundul	<i>Xylocarpus granatum</i>
Kankra	<i>Bruguiera sexanula</i>
Khalshi	<i>Aegiceras corniculatum</i>
Shingra	<i>Cynometra ramiflora</i>
Goran	<i>Ceriops decandra</i>
Kirpa	<i>Lumnitzera racemosa</i>
Hantal	<i>Phoenix paludosa</i>

**4.8.5 Other Potential Areas for Plantation**

Existing land use of the project area (BSMSN) indicates the fact that currently about **9,550 acres of plantation** existing within the premises of the said industrial city which will be impacted (lost) due to development of the city. Detailed consultation with DFO Coastal Plantation, Chittagong it was suggested that BEZA can take initiative for plantation in other potential areas which is shown in **figure 4-27 and Table 4-36**.

*Table 4-36: Other Potential Areas for Plantation*

Plantation Locations	Area to Be Planted in Acres
Total <b>Subarna Char</b> - low line water line area of Subarna Char will be kept for green coverage.	24,924.00
40% of the reclaimed <b>Sabuj - Char</b>	7048.00
<b>Sabuj Char</b> - low line water line area of Sabuj Char will be kept for green coverage.	10,404 .00
60% - low line water line area of <b>Sandeep Char</b> will be kept for green coverage	6,000.00
<b>Total Proposed Plantation Area</b>	<b>48,376 Acres</b>



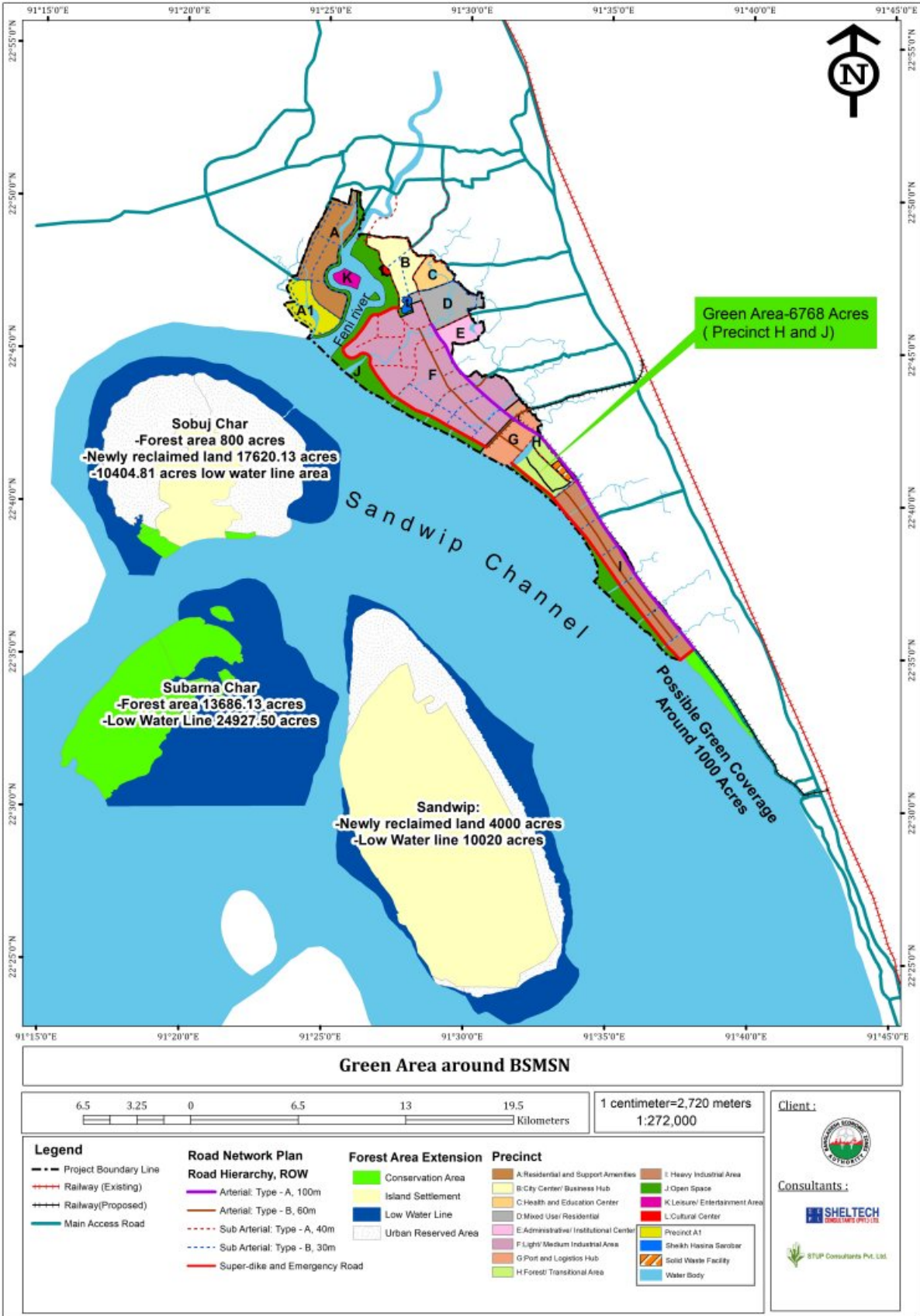

Figure 4-27: Green Areas Around BSMSN

#### 4.8.6 Costing of the BSMSN Plantation Plan

The total plantation costs are estimated at approximately 107 million BDT, considering the per square meter cost at 70 BDT (See Section-4.10).

### 4.9 Waste Management

#### 4.9.1 Background Analysis

BSMSN will be the first multi sector economic zone in Bangladesh, located in Mirsarai and Sitakunda Upazilla of Chittagong district and Sonagazi Upazila of Feni district. For planning and development of BSMSN “Eco-efficient and Sustainable Urban Infrastructure approach- An Initiative for Green Economic Growth” concept has been adopted which will help Bangladesh to achieve the United Nations’ Agenda 2030, with its Sustainable Development Goals (SDGs). In the proposed BSMSN about 33805 acres of land will be developed into 12 Precincts. Each precinct will have specific or restricted land use.

##### a. Type of Waste Generated in BSMSN

In the proposed industrial city 33,805 acres of land has been proposed for development. Out of which 15,781 Acres has been proposed exclusively for industrial activities which will include Light Industrial Area, Port and Logistics Hub and Heavy Industrial Area. Land area of 18,024 acres has been proposed for non-industrial activities like - Residential Area, Center /Business Hub, Health and Education Centre, Mixed Use/Residential, Institutional and Administrative Centre, Forest Conservation Area, Open Space and Leisure/Entertainment Area.

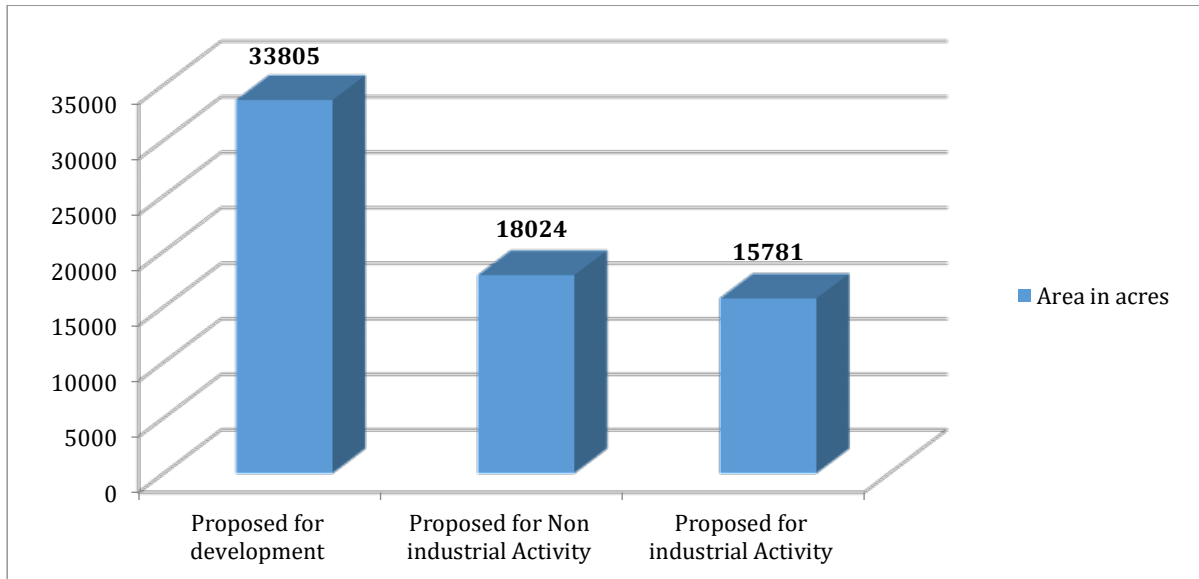

Figure 4-28 Land Area for Industrial and Non-Industrial Activities

Two types of Waste will be generated from both industrial as well as non-industrial areas – Solid waste and Liquid waste. Municipal solid waste (MSW) will be generated from house hold activities, commercial activities, institutions and from health care units. Industrial solid waste (ISW) be will generated from industries. Both MSW and ISW may be hazardous and non-hazardous in nature. **Tables 4-37** indicates the type of waste to be generated from various activities of the industrial city. **Figure 4-29** indicates the waste flow diagram of the proposed industrial city.

Table 4-37 Type of Waste Generation in BSMSN

Land Use of Precincts	Area in Acres	Type of Solid Waste Generation						
		Municipal Solid Waste (MSW)		Industrial Solid Waste (ISW)		Biomedical Waste	Domestic Sewage	Industrial Waste Water
		Non-Hazardous	Hazardous	Non-Hazardous	Hazardous			
Residential and Support Amenities	4606.57	√	√				√	
City Center/Business Hub	1682.91	√	√				√	
Health and Education Center	837.35	√	√			√	√	
Mixed Use/Residential	1778.59	√	√				√	
Administrative/Institutional Center	880.68	√					√	
Light/Medium Industrial Area	10043.12	√		√	√		√	√
Port and Logistics Hub	1802.29	√		√	√		√	√
Forest/Transitional Area	1778.75	√					√	
Heavy Industrial Area	3956.35	√		√	√		√	√
Open Space	6030.42	√					√	
Leisure/Entertainment Area	350.89	√					√	
Cultural Center	56.85	√					√	

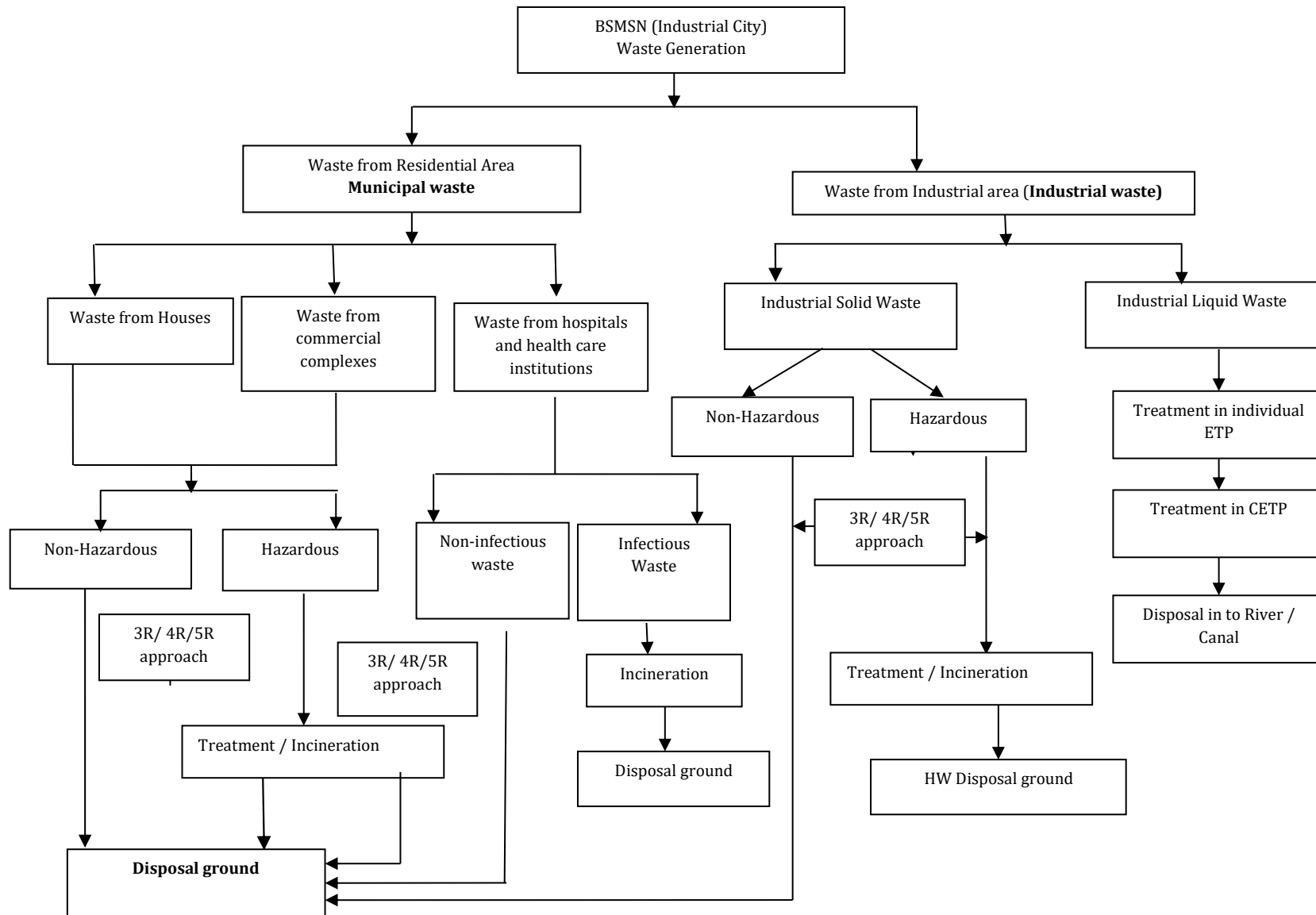

Figure 4-29 Waste Flow Diagram for BSMSN

#### 4.9.2 Waste Management Plan Approach

##### a. Considerations for a Waste Management Plan

Considerations for preparation of the Waste Management Plan are:

- Liquid waste in the form of Domestic Sewage and Effluent (Wastewater) from industries has not been considered in this section of the report. It has been explained in Chapter 3 of this report that Domestic sewage will be treated in 2 STPs proposed in the suitable locations within the Industrial city premises. Waste water discharged by individual industries will be treated in the individual ETPs of the industry as per the guideline provided by the Industrial City authority and will be discharged in to CETPs suitably located within the Industrial city premises for final treatment and will be discharged in to nearby River / Canal as per DOE, GOB national waste water discharge standard.
- Waste Management Plan for the Industrial city has been prepared based on the relevant Acts, Laws, Rules, Circular, Guidelines and document related to Bangladesh and international practices as listed in **Table 4-38** Policy Legal Framework for Waste Management of BSMSN, of this report .

##### b. Steps for a Solid Waste Management Plan

Solid Waste Management Plan for the proposed BSMN (Industrial city) has been discussed in following Sections:

- Characterization and estimation of Municipal Solid Waste (MSW) generation in the year 2040 in BSMSN
- Land area required for disposal of the MSW in 2040
- Guidelines / policies to be adopted by the authority for management of MSW
- Characterization and estimation of Industrial Solid Waste (ISW) generation in the year 2040 in BSMSN
- Land area required for disposal of the ISW in 2040
- Guidelines / policies to be adopted by the authority for management of ISW.

Table 4-38 Policy Legal Framework of Waste Management of BSMSN

Sl.	Legal Instruments	Key Features Related to Waste Management
1.	Constitution Article 18A	Constitution Article 18A of the constitution of Bangladesh narrates that: "The State shall endeavor to protect and improve the environment and to preserve and safeguard the natural resources, bio- diversity, wetlands, forest and wild lives for the present and future citizens".
2.	The Seventh Five Year Plan (2016-2020)	<p>In the sub-section of internal environment management, the Seventh Five Year Plan has given impetus on preparing a guideline of e-wastes based on a baseline survey. In addition to that the plan proposes some activities for E-waste management. Taking cognizance of the nature and scale of E-waste problem in the country, the plan suggests the following programs.</p> <ul style="list-style-type: none"> <li>- Initiating studies to understand the nature and magnitude of E-waste nationwide and developing an Action Plan accordingly.</li> <li>- Undertaking measures to implement the Action Plan.</li> <li>- Establish efficient collection system for selected electronic waste.</li> </ul> <p>In line with the E-waste Management Rules (Draft) 2011, and Hazardous Waste Management Policy of Bangladesh (Draft) 2009, the Sixth Five Year Plan prominently sheds light on the E-waste issues in Bangladesh.</p>
3.	Basel Convention	<p>The Basel Convention provides embargo on trans-boundary movement of hazardous waste (Leitzman, Levinson and Folman 2009).</p> <p>Bangladesh is a signatory to Basel convention and also has accessed to this Convention on April 01, 1993. The Convention asks the signatory countries to take measures on hazardous waste management (Rahman et al 2014).</p> <p>So it is evident that Bangladesh is committed to international community for taking measures on hazardous waste management within its boundary</p>
4.	The National Environment Policy, 1992	<p>The National Environment Policy (NEP), 1992 has set the policy framework for environmental action with a set of sector-wise guidelines. The Policy embraces a number of related different sectors including ecological balance and overall development.</p> <p>The central theme of the policy is to ensure the protection and improvement of the environment. It also gives the discretion of amending the existing laws, formulating the new laws and implementing the same. It also assigned the Ministry of Environment and Forests to coordinate the implementation of the policy and to constitute a high level National Environmental Committee (NEC) with the head of the government as the chairperson.</p> <p>However, it is learnt from DoE that it has revised the Environment Policy '92 to make it updated and compatible with the current national and international situation. The Policy covers the environmental issues in a whole package. It does not give emphasis on any issues of the environment separately. Likewise, regarding waste the Policy does not suggest any guidelines or measures for waste management (moef.gov.bd).</p>
5.	Environment Conservation Act 1995 (Revision up to 2012)	<p>The Environment Conservation Act 1995 (ECA 1995) is currently the main act governing environmental protection in Bangladesh. The Act was designed to preserve the environment through improving environmental standards and controlling and mitigating environmental pollution. The major objectives of ECA'95 are: conservation of the natural environment and improvement of environmental standards, and control and mitigation of environmental pollution. The strategies of the act focus on promulgation of standard limit for discharging and emitting waste and hazardous waste import, transportation, storage etc.</p> <p>Environment Conservation Act (ECA), 1995, authorized the DoE to undertake any activity necessary to conserve and enhance the quality of the environment and to control, prevent</p>

Sl.	Legal Instruments	Key Features Related to Waste Management
		<p>and mitigate pollution. The DoE was also mandated to give clearance on environmental issues for any new project (moef.gov.bd).</p> <p>The Act was subsequently amended 2000, 2002, and 2012.As said by the Act in its regulation number 20, the government can enact rules for the control of environment pollution. Subsequently, circulars and notifications were issued for implementing the Act.</p> <p>However, the Act failed to suggest any monitoring mechanism for the enforcement of its provisions (moef .DOE, 2006).</p>
6.	Environmental Conservation Rules 1997	<p>The Environmental Conservation Rules (ECR) 1997 set by the government of Bangladesh for the protection of environment. ECR has the mandate for all industries to carry out Environmental Impact Assessment (EIA). The Rules instructs all industries to install waste/pollutant treatment plants for controlling environment pollution. In addition to that all industries will conform to environmental quality standards, report accidents or unforeseen discharge of pollutants and take remedial measures under ECR (MoEF 2006). Environment Conservation Rules of 1997, divided industries and projects into different categories depending upon the pollution load and likely impact on the environment. ECR gives mandate to DoE to issue 'No Objection Certificates' (NOC) to those- E waste management companies that conform to mandated ECR standard.</p> <p>However, no rules found in ECR to deal particularly with waste issue in Bangladesh (moef.gov.bd).</p>
7.	The Factory Act, 1965	The act address with cleanliness, disposal of wastes and polluted liquids, air circulation and temperature control, control of dust, sand and smoke, artificial ventilation, heavy traffic arrangement of sufficient light, drinking water, toilet, latrines etc. within the mills and factories.
8.	The Environment Court Act, 2000	The Environment Court Act (ECA), 2000 was subsequently amended in 2002. It provides frameworks for setting up one or more environmental courts with clear and specific terms of reference to deal with environmental offences (MOEF, 2006:25). Initially every division of the country a court will be established (moef.gov.bd)
9.	Ozone Depleting Substance (Control) Rules 2004 (Amendment 2014)	Ozone Depleting Substance (Control) Rules 2004 have been prepared under the Environmental Conservation Act 1995. Use of Ozone depleting substances has been prohibited under the schedule (1) column (2) of this rule. In addition to that according to regulation 4 of sub section 2 of the Rules, anybody could not produce, import, and export ozone depleting substance.
10.	Draft National Solid Waste Management Handling Rule, 2011	3R principle has been used for Solid waste management
11.	Ship breaking and Hazardous Waste Management Rules, 2011	The rules have been formulated under Environmental Conservation Act 1995. In the rules described the process of hazardous waste safe management. It includes waste which is by nature physically reactive, toxic, flammable, explosive and corrosive or other waste properties that can damage health and environment.
12.	Bangladesh Standards and Guidelines for Sludge Management,	Standards and Guidelines for Sludge Management is a way forward for managing sludge that poses serious threat to the environment. The guideline provides extensive information on all aspects of sludge management. This guideline describes various methods of sludge treatment and disposal.

Sl.	Legal Instruments	Key Features Related to Waste Management
	2015	
13.	Medical Waste Management Rules, 2008	The rule is prepared under the environmental conservation act 1995. The rules described important definition; formation of authority and responsibility; license issue and cancelation; responsibility of registered vendors; segregation, packaging, transportation and hoarding; elimination and purification; classification waste for medical waste management. The rules address waste management issues mainly in the context of medical wastes.
14.	Managing Hazardous Wastes – ADB report, 2010	Bangladesh has compiled inventories in key sectors and developed draft policy and strategy and rules have been drafted for management of industrial hazardous waste.
15.	Guidelines for E-waste Management in Bangladesh, 2012	This guideline on WEEE/ E-waste has been prepared as a guidance document to support WEEE/ E-waste inventorisation and assessment of risks involved. This guideline will complement the e-waste management rules that will help to enforce the e-waste management in Bangladesh
16.	Clean Development Mechanism (CDM) 2012	Under the Kyoto Protocol, CDM is a mechanism that allows developed countries to achieve part of their greenhouse gas emissions reduction obligations through investment in projects in developing countries that reduce greenhouse gas, fix, or sequester carbon dioxide from the atmosphere (Waste Concern Consultants, 2010). The strategy is promoting pro-poor through CDM sector by harnessing carbon financing (ESDO, 2012).
17	Lead Acid Battery Recycling and Management Rules, 2006	The rules have improved the collection and recycling lead acid battery (Waste Concern Consultants, 2010).
18	National 3R Strategy for Waste Management 2009	The solid waste management rules based on the 3R principle as well as hazardous waste management rule. 3R means reducing waste, reusing and recycling resources and products. The strategy clarifies the concepts of reducing, reusing and recycling. The Strategy facilitates four manuals on four different types of wastes: solid waste, bio-medical waste, industrial waste and agricultural waste
19.	National Environmental Management Action Plan (NEMAP), 1992	National Environmental Management Action Plan (NEMAP) is an environmental planning exercise undertaken by the government through MOEF. In companion with NEP the Plan was carried out in three phases between 1992 and 1994 (moef.gov.bd). During the first phase undergoing rapid environmental degradation was identified. The second phase saw prioritization of sectoral issues. Finally, the third phase witnessed elaborate public consultation exercise with assistance from NGO personnel, academicians, lawyers, journalists and other professionals. However, E-waste issue was not addressed in it.
20..	National Renewable Energy Policy, 2008	This policy focuses on promoting production of biogas and other green energy from waste and also providing incentives for Clean Development Mechanism to encourage green energy projects (mpemr.gov.bd).
21.	National Science and Technology Policy-2011	The preamble of the National Science and Technology Policy paragraph number 1.4 highlighted that science and technology is an instrument of change that can play a decisive and pivotal role in achieving the national goals on poverty reduction and ensuring sustainable development through value addition to resources, creation of jobs, reducing environmental pollution, control and mitigation of natural hazards, increasing production and improving life style of people belonging to different strata of people One of the missions of this policy is to encourage research on green technology to harness natural resources; ecosystem which acts as a carbon sink and a buffer against climate



Sl.	Legal Instruments	Key Features Related to Waste Management
		change; information and communications technology, biotechnology, nanotechnology etc. (most.gov.bd).
22.	National Industry Policy 2016	Chapter 14 of National Industry Policy 2016 highlighted environment friendly Industry management. The policy stated that Government will provide all sorts of co-operation and incentives to the local and foreign entrepreneur for managing and processing industry waste. Besides, industry entrepreneur has to be influenced to follow 3R (Reduce, Reuse and Recycle) strategy for waste management (moind.gov.bd).
23.	National Information and Communication Technology (ICT) Policy 2015	The objective of the National ICT policy the section D 9 tells that steps will be taken for the reduction of risk on climate change. By the innovation of environmentally friendly green technology initiatives will also be taken for safe E-waste management, climate and disaster management. In addition to that, the policy in Section E defines strategic themes. The section describes the five strategies for environment, climate and disaster management.
24.	The National Land Use Policy 2001,	The National Land Use Policy 2001, of the Ministry of Land focused on the necessity, the importance and modalities of land zoning for integrated planning and management of land resources of the country. It also mentioned the need of formulating a Zoning Law and Village Improvement Act for materializing the identified land zoning area. Provision of 3(Ka) of Non-Agriculture Khash Land Management and Allocation Guideline 1995 require a body purchasing khash land from government to fulfill their objectives. Therefore, identified location is required in every district for waste management and there should have a provision in the Non-Agricultural Khash Land Management and Allocation Guidelines to that purpose (minland.gov.bd).
25.	Fertilizer Act, 2006	Under this act compost has been promoted and standard of compost has been set by the government on 2008.
26.	Import Order Policy 2015-2018	The policy describes list of import of prohibited goods. Paragraph number (5) defines prohibition of imported goods like recondition office equipment, photocopier, type writer machine, telex, phone, fax, old computer, and refurbished computer and electronics accessories. It means that Bangladesh has banned import of all sorts of E-waste in the Import policy
27.	Urban Management Policy Statement, 1998	The policy considers the interest of providing economic, efficient and reliable services; municipalities shall endeavor to contract out solid waste disposal, public sanitation, drain cleaning and road maintenance.
28.	The Penal Code	It provides with six months imprisonment or fine to Taka 2000(BDT) or both for causing public nuisance with respect to negligence about spread of life-threatening infectious disease, causing damage to climate, negligence about poisonous substances. It also empowers a magistrate of jurisdiction to pass conditional order for removal of nuisance.
29.	The Dhaka Municipal Ordinance, 1983	The ordinance authorizes Dhaka City Corporation (DCC) to take the responsibility of removal, collection and disposal of refuse, management of latrines and urinals, control on dyeing and tanning skins, bricks, kilns, medical practice on infectious diseases and direction towards house scavenging, cleaning drainage, cleansing of streets etc.
30.	The City Corporation Act, 2009	States the following regarding waste management in urban regions of Bangladesh. It starts with "Waste removal, collection and its management"
31.	Circular to Promote Compost by the Ministry of Agriculture (MoA), on 23 April 2008	Waste and 3R Related Requirements - Ministry of Agriculture issued a circular to promote use of compost amongst the farmers to reduce environmental damages from use of chemical fertilizers, which could also reduce government's financial burden for subsidizing chemical fertilizer

Sl.	Legal Instruments	Key Features Related to Waste Management
32.	Private Sector Infrastructure Guideline 2004	This guideline of the GOB has recommended private sector investment in waste management sector which includes all types of waste. It has also identified waste sector as one of the priority sector for private investment.
33.	Private Sector Housing Development Guideline 2005	This guideline recommends to space in new housing areas for waste recycling specially composting and biogas generation.
34.	Dhaka Declaration on Waste Management by SAARC Countries During 10-12 October 2004	SAARC countries agree to encourage NGOs and private companies to establish community-based composting, segregation of waste at source, separate collection and resource recovery.
35.	Solid Waste Management Action Plan for Eight Secondary Towns in Bangladesh 2005	Under the Secondary Towns Integrated Flood Protection (Phase-2) Project of Local Government Engineering Department, GoB. This action plan is based on 4R principle I.E. reduce, reuse, recycle and recovery of waste.
36.	National Environmental Management Action Plan (NEMAP) 1995	This was a plan of the Government of Bangladesh (GoB), prepared by the Ministry of Environment and Forest (MoEF) in consultation with people from all walks of life. 3R is being promoted under the Sustainable Environment Management Program (SEMP) of NEMAP.
37.	Poverty Reduction Strategy Paper (PRSP) 2005	This paper promoted EMS. To improve the solid waste management situation, special focus was given to segregation of waste at source along with the promotion of recycle, reduce and reuse of industrial and other solid waste etc.
38.	Electrical and Electronic Waste (Management and Handling) Rules (2011)	This e-waste management rules will help to enforce the e-waste management in Bangladesh
39.	National Sanitation Strategy 2014	The goal was to achieve 100% sanitation coverage by 2010. Here resource recovery and recycling as given top priority to improve urban sanitation situation instead of disposal.
40.	A Strategy for Sustainable Waste Management Swedish EPA 2005	In this Strategy for Sustainable Waste Management Government wish to place the material recovery, biological treatment and incineration for energy recovery as a result of more sorting of waste at source and changes in waste treatment and reduce land filling
41	Enhancing Opportunities For Clean/ Resilient Growth In Urban Bangladesh Country Environmental Analysis 2018, The World Bank	This document has reviewed the existing environmental regulations in Bangladesh including BEZA Act 2010 and could find the gaps in relation to the present Environmental situation in Bangladesh and suggested opportunities and modification / amendment of some act for clean growth in Bangladesh.

### 4.9.3 Management of Municipal Solid Waste (MSW)

#### a. Characterization and Estimations of Municipal Solid Waste (MSW) Generation in the year 2040 in BSMSN

Municipal solid waste (MSW) is comprised of a number of solid waste streams. The following solid waste streams that compose MSW are:

- **Residential Solid Waste** – Solid waste generated from single-family residences, and multifamily residences. Recyclables prevalent in the residential waste stream include paper, plastics, metals, food scraps, yard trimmings, textiles and personal electronics.
- **Commercial Solid Waste** - Solid waste generated from businesses, offices, stores, markets, institutions, government, and other commercial establishments. Recyclables common in the commercial waste stream include paper, plastic, metals, food, yard trimmings, lumber, textiles, and electronic devices.

Other solid waste streams that may also be a part of MSW include:

- **Bio-Medical Wastes** – treated waste, where allowed, generated from hospitals and other acute care facilities, health research institutions and homes that result from the use and administration of medications, surgery or other medical procedures, or medical or health research and development.
- **Bio-Solids** – typically waste generated from the de-watering of municipally generated wastewater.
- **Construction and Demolition Debris** - materials resulting from the construction and demolition (CandD) of buildings and other structures, including materials such as metals, wood, gypsum, asphalt shingles, roofing, concrete, rocks, rubble, soil, paper, plastics and glass wastes. CandD components can be a significant portion of the MSW stream with a high potential for recycling. Non-recyclable CandD wastes may be disposed in municipal solid waste landfills or specially designated landfills, or if cleaned of unacceptable debris, used for land reclamation.
- **Others** – There are a host of other separately managed solid wastes that may be a part of MSW such as tires, street sweepings, storm catchment wastes, automotive shredding fluff, carpet, white goods, furniture and mattresses.

Based on the review of the documents<sup>23</sup> the average characteristics of the Municipal Solid Waste to be generated from the proposed industrial city have been presented in **Table 4-39**. It indicates that 83% of the materials are biodegradable material and 17% is non-biodegradable material.

Table 4-39: Average Composition of MSW Anticipated in BSMSN

Sl. No.	Components	% Composition
1.	Food and Vegetable Waste	69.0
2.	Bones	0.75
3.	Paper Products	9.30
4.	Plastic	4.75
5.	Rags./Textiles/Jute	3.06
6.	Glass	0.83
7.	Leather /Rubber	0.50
8.	Metals	0.2
9.	Ceramics	0.2
10.	Soil / Ash	3.8
11.	Wood/ Grass/ Leaves	3.78
12.	Medicinal/ Chemical	0.87
13.	Rocks/Dirt/ Misc	3.35

It may be mentioned based on **Table 4-39** that Food and vegetable waste will dominate (69%) the MSW followed by Paper products (9.3%) and plastic (4.5%). Out of total waste generation 25 % of the material will be recycled, 10% of the material will be composted, 13% of the material will be used for combustion for energy generation or as fuel in other industries and 52% of the material will be sent to land fill site for disposal<sup>24</sup>.

It has been estimated that total Waste Generation in 20 Years (in 2040) will be **11.27 x 10<sup>6</sup> tons** considering Population 4.41 million in 2040 and waste generation 0.350 kg/ capita/ day.

#### b. Land Area Required for Disposal of the MSW in 2040

It has also been estimated that area required for only MSW land fill will be 185 acres and total land requirement considering other facilities like composting plant, different infrastructure, area for biomedical waste and separate area for hazardous waste storage and management will be about 274 acres (**Annexure 4.9 and Figure 4-30**). If the industrial city authorities (BEZA) adopt 3R / 4R / 5R strategy and global trend in developed countries as reported by EPA the land demand for land fill will reduced to 52% i. e 142.5 acres.

A specific site in Precinct H (Transitional Area) is selected as the land fille site, land for storage and primary processing of industrial solid waste and land for storage and transfer station. Also, there will be thirty

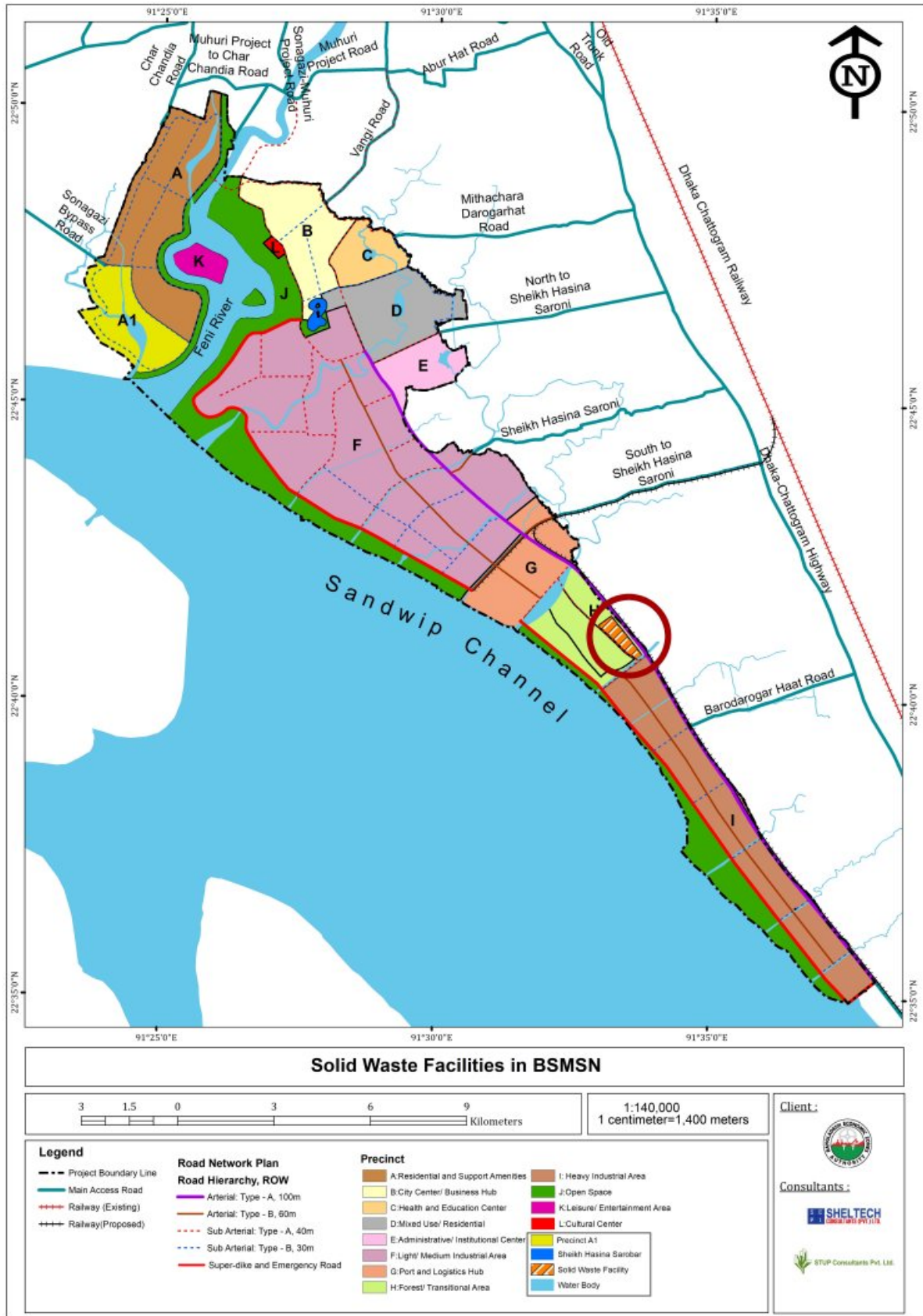

Figure 4-30: Solid Waste Facilities in BSMSN

secondary transfer station in whole BSMSN area. Location of each utility installation point has been selected as per the prescribed guidelines mentioned in Section 3.1 of Chapter 3.

In master plan it has been suggested that use of polythene bag / plastic bag should be prohibited within the BSMSN. Entire BSMSN should be a plastic free zone. Waste management program will be implemented in Bangladesh through national 3R (Reduce, Re-use and Recycle) policy, CDM technology, industrial metabolism concept and Industrial Symbiosis and By-Product Exchange

### **c. Guidelines to be Adopted for the Management of SWM in BSMSN**

The Government of Bangladesh has developed very useful guidelines, laws acts, regulations considering different situations and problems for waste management however sometimes, these may need further amendments and/or modifications. It should be noted that Bangladesh does not have a national waste management strategy. As a result, waste management is viewed on a project by project basis, and solely as the responsibility of engineers to determine appropriate collection and disposal measures. Yet for BSMSN, waste management is more than a technical issue. It requires social, fiscal and administrative solutions in addition to technical solutions.

It is anticipated that BSMSNs approach to waste management system would be unconventional. I.E. An end of pipe solution such as a focus on collection and disposal as well as reuse and reduction.

BEZA will prepare an Integrated Solid Waste Management Plan (ISWM) for BSMSN based on existing laws, acts, regulations circular and guidelines, which are listed below. These are all national guidelines and are related with the preparing the ISWM. Success of the ISWM will depend on the implementation of the plan and capacity development. BEZA can also formulate its own guidelines, based on the following documents and future SWM

- National 3R Strategy for Waste Management 2009
- Draft National Solid Waste Management Handling Rule, 2011(to be finalised soon)
- Medical Waste Management Rules, 2008
- Environment Conservation Act 1995 (Revision up to 2012)
- Environmental Conservation Rules 1997
- The Environment Court Act, 2000
- Ozone Depleting Substance (Control) Rules 2004 (Amendment 2014)
- Bangladesh Standards and Guidelines for Sludge Management,2015
- Managing Hazardous Wastes – ADB report ,2010
- Guidelines for E-waste Management in Bangladesh, 2012
- Lead Acid Battery Recycling and Management Rules, 2006
- National Renewable Energy Policy 2008
- The National Land Use Policy 2001
- Fertilizer Act, 2006

- Urban Management Policy Statement, 1998
- The Dhaka Municipal Ordinance, 1983
- The City Corporation Act, 2009
- Circular to Promote Compost by the Ministry of Agriculture (MoA), on 23 April 2008
- Private Sector Infrastructure Guideline 2004
- Private Sector Housing Development Guideline 2005
- Solid Waste Management Action Plan for Eight Secondary Towns in Bangladesh 2005
- Electrical and Electronic Waste (Management and Handling) Rules (2011)

Because there are no specific guidelines or rules for the management of solid waste in Bangladesh, BEZA may request DOE, MOEF to finalise the **Draft National Solid Waste Management Handling Rules, 2011** since BSMSN will be a new city and it will be easy to implement the rules from the beginning.

#### **4.9.4 Management of Medical Waste (MW)**

Medical activities safeguard the health of the community but their functioning results in the production of wide varieties of wastes. MW which is also referred as clinical waste has to be handled and disposed in a proper manner to eliminate the possibility of injury or infection and safeguarding the environment as a whole. The impacts associated with improper MWM can damage the environment and affect public health directly and indirectly.

Medical wastes contain both general wastes (app. 75-80 per cent) and infectious wastes (app. 20-25 per cent). MW constitutes a public health hazard, if not managed properly. Although majority of the MW is no more dangerous than household/municipal waste, the hazardous waste, if exposed to the people or environment in an untreated form, pose various kinds of danger. Thus, the main concern relates to the portion of MW that is defined as hazardous.

In this industrial city master plan about 815 acres of land area has been earmarked for health care institutions which will generate special type of waste – Medical Waste or Hospital Waste. This type of waste needs to be managed according to Medical Waste Management Rules, 2008, GOB. According to the Ministry of Health and Family Welfare (MOHFW), Government of the People’s Republic of Bangladesh (2016) – “Government (through Department of Environment) has declared Medical Waste (management and processing) Rule November, 2008, which serves as the main code to be followed by all concerned agencies for proper management and disposal of MW and thus safeguard the environment. Onward efforts to follow the code have to be started for ensuring standard MWM in the country.”

#### **4.9.5 Management of Plastic Waste**

Bangladesh is world leader in banning plastic bags. Bangladesh was the first country to ban plastic bags in 2002 and over a decade later many developed countries are still struggling to emulate this success. Although plastic bags make up only a small percentage of all litter, the impact of these bags is significant.

With overwhelming support from user to manufacturers and exporters, the MOEF placed a proposal before the Cabinet to ban the production and use of polyethylene shopping bags in Dhaka city from January 1, 2001. The Cabinet agreed with the MOEF proposal.

The Ministry then started a vigorous campaign from market to market for sensitization and motivation and announced that January 1, 2002 shall be the cutoff date for production and use of 20-micron thick polyethylene shopping bags in Bangladesh. The Bangladesh Environment Conservation Act was formulated in 1995. The law of Section 1 under this act was revised in 2002. According to Rule 6 (ka) of Clause-5 under Section-9, restriction has been imposed in the production and uses of polythene shopping bag. According to the rule, there is restriction on the production and sale of environmentally harmful products. If it is proven that any kind of plastic bags or products made of polyethylene or poly-propylene is detrimental for environment then government could control/ ban the use of these products to any selected area or all over the country. Under the rule 6(ka) the penalty and punishment provisions has been introduced on violation of the act.

In the same line BEZA may declare the BSMSN as a “**Plastic Free City**” and all types of polythene bag should be banned in the industrial city. No polythene bag should be collected during waste collection and target should be fixed not to send any plastic bag to the disposal site.

At present there is no guideline or rules available for management of Plastic waste in the Bangladesh. Plastic products other than the polythene bag should be recycled (100%) as per national 3R policy of Government of Bangladesh. The national 3R goal for waste management is to achieve higher levels of waste reduction, reuse, and recycling and minimize waste disposal on open dumps, rivers, flood plains and landfills.

#### **4.9.6 Management of Industrial Solid Waste (MSW)**

##### **a. Characterization and Estimation of Industrial Solid Waste (ISW) generation in the year 2040**

For developing countries, industrialisation is a must to build self-reliance and in uplifting nation’s economy. However, industrialisation on the other hand has also serious problems relating to environmental pollution. Therefore, wastes seem to be a by-product of growth. The countries like Bangladesh can ill-afford to lose them as sheer waste. On the other hand, with increasing demand for raw materials for industrial production, the non-renewable resources are dwindling day-by-day. Therefore, efforts are to be made for controlling pollution arising out of the disposal of wastes by conversion of these unwanted wastes into utilizable raw materials for various beneficial uses.

Industries find it easy to dispose waste here and there and it makes difficult for local bodies to collect such waste though it is not their responsibility. In some cities, industrial, residential and commercial areas are mixed and thus all waste gets intermingled. Therefore, it becomes necessary that the industrial zone authority (BEZA) along with Department of Environment work out requisite strategy for organizing proper collection and disposal of industrial solid waste.

In Bangladesh, management of industrial solid waste (ISW) is not the responsibility of local bodies (Corporation / Municipalities / Union parishad). Industries generating solid waste have to manage such waste by themselves and are required to seek approval from Department of Environment (DOE) under relevant rules and if it is within a Economic zone then from DOE as well as from Zone authority

##### **b. The Problems Associated with Management of ISW in Bangladesh**

Generally, in an Industrial Zone Industries are required to collect and dispose off their waste at specific disposal sites designated by the zone authority **and** such collection, treatment and disposal is required to be monitored by the concerned zone authority **and** time to time by Department of Environment (DOE, GOB). The following problems are generally encountered in Industrial Zones of Bangladesh while dealing with industrial solid waste



- There are no specific guidelines for management and disposal of industrial waste
- There are no specific disposal sites where industries can dispose their waste
- Mostly, industries generating solid waste in city / Industrial zone and town limits do not seek consents of concerned DOE, GOB
- Most industries do not disclose their ISW management plan / disposal plan while taking Environment clearance (EC) from DOE, GOB
- Industries are located in non-conforming areas and as a result they cause water and air pollution problems by disposing solid waste
- Industrial estates located in city limits do not have adequate facilities so that industries can organize their collection, treatment and disposal of liquid and solid waste
- There is no regular interaction between urban local bodies and DOE, GOB to deal such issues relating to treatment and disposal of waste and issuance of licenses in non-conforming areas
- There is no regular interaction between Industrial zone authority, urban local bodies and DOE, GOB to deal such issues relating to treatment and disposal of waste and issuance of licenses in non-conforming areas
- Lacks of awareness of **4R approach (Reduce, Reuse, Recycle and Recovery)** among the industry owners and facility providers like industrial zone authorities.
- Industrial zone authorities overlook the concept of **4R approach** while planning for industrial zones / industrial estates and also during allotment of land for industries

BSMSN, which is a combination of land uses must synthesize the above while planning for its Industrial Solid Waste Management strategy and plan.

**c. Generation of Industrial Solid Waste**

The major generators of industrial solid wastes are the: i) thermal power plants producing coal ash, ii) iron and steel mills producing blast steel melting slag, iii) non-ferrous industries like aluminum, zinc and copper producing red mud and tailings, iv) sugar industries generating press mud, v) pulp and paper industries producing lime and vi) fertilizer and allied industries producing gypsum.

*Table 4-40 Source of Generation of Some Major Industrial Solid Waste*

S.No	Name of the Waste Product	Source/Origin/ Industry
1.	Blast furnace slag and steel melting slag	Conversion of pig iron to steel and manufacture of iron
2.	Brine mud	Caustic soda industry
3.	Copper slag	By product from smelting of copper
4.	Fly ash, bottom ash, slag and boiler dust	Coal based thermal power plants
5.	Kiln dust, Cement particulates and dust	Cement plants
6.	Lime sludge	Sugar, paper, fertilizer tan-neries, soda ash, calcium carbide industries
8.	Phospho gypsum	Phosphoric acid plant, Ammonium phosphate

S.No	Name of the Waste Product	Source/Origin/ Industry
9.	Waste paper	Paper and cardboard industry
10.	Edible oil and fat waste	Edible oil industry
11.	Cloth pieces and paper, impregnated textile, elastomer, plastomer	Textile industry
12.	Animal waste	Meat processing industry
13.	Fruit and vegetable waste	Food processing industry
14.	Baking and confectionery waste	wastes from the baking and confectionery industry
15.	Waste plastics and rubber	Plastic industry, tyre industry
16.	Leather and fur	Leather product industry.
17.	Acid tars, other tars, tank bottom sludge and bitumen	Petroleum and refinery industry
18.	Pharmaceuticals waste	Pharmaceuticals industry
19.	Waste ceramic powder and ceramic products	Ceramic industry
20.	Waste adhesives and sealants	Water proofing industry
21.	Photographic film and paper free of silver or silver compounds	Photographic industry
22.	Ferrous metal Filings and turnings	shaping and physical and mechanical surface treatment of metals and plastics
23.	Hydraulic oils, containing PCBs, mineral-based chlorinated engine, gear and lubricating oils	Automobile manufacturing industries
24.	Paper and cardboard packaging, plastic packaging materials	Paper industry and Packaging industries
25.	Absorbents, Filter materials (including oil Filters not otherwise specified), wiping cloths, protective clothing contaminated by dangerous substances	Automobile manufacturing industries, oil and petroleum industry
26.	Transformers and capacitors, discarded equipment, Electric cables, insulation materials	Electrical and electronic industry
27.	Lead batteries, Ni- cd batteries, mercury-containing batteries, alkaline batteries, other batteries and accumulators	Batteries and accumulators industries
28.	Metal waste – aluminium, Iron and steel, mixed metals	Metal processing industries
29.	Infectious and non infectious medical waste	Wastes from human or animal health care centres
30.	Electronic wastes, Computer monitor, chips, circuits etc.	Computer assembly , Mobile manufacturing , TV production and assembly and electronics industry

*(Source: National Waste Management Council- Ministry of Environment and Forests, India -1990 /1999, Bangladesh Standards and Guidelines for Sludge Management DOE, GOB, 2015)*

Based on the review of the documents<sup>25</sup> and data reviewed from different industrial zones / parks from Bangladesh, India, Thailand and China the type of waste to be generated from the proposed industrial park<sup>26</sup> and their characteristics has been presented in **Table 4-41** of this report.

The table indicate the fact that - total amount Industrial Solid Waste to be generated from the proposed industrial city in the year 2040 will be 288925 tons out which 250751 tons will be non-hazardous industrial waste and

<sup>25</sup> Refer table 2

<sup>26</sup> BSMSN

38174 tons will be of hazardous in nature. It indicates the fact that 86.78% of the waste will be of non-hazardous in nature and 13.22 % of the waste will be of Hazardous in nature. Table also indicate that out of total waste 68% of the waste is of recyclable and 32% is non-recyclable in nature.

**d. Policy Legal Framework for Industrial Waste Management Of BSMSN**

Following acts, rules, regulations and guidelines are applicable to the Industrial Waste Management of BSMSN

- Basel Convention 1993
- National 3R Strategy for Waste Management 2009
- National Industry Policy 2016
- Environment Conservation Act 1995 (Revision up to 2012)
- Environmental Conservation Rules 1997
- The Environment Court Act, 2000
- Clean Development Mechanism (CDM) 2012
- Ozone Depleting Substance (Control) Rules 2004 (Amendment 2014)
- Bangladesh Standards and Guidelines for Sludge Management,2015
- Managing Hazardous Wastes – ADB report ,2010
- Guidelines for E-waste Management in Bangladesh, 2012
- Lead Acid Battery Recycling and Management Rules, 2006
- National Renewable Energy Policy 2008
- Ship Breaking and Hazardous Waste Management Rules, 2011
- Electrical and Electronic Waste (Management and Handling) Rules (2011)



Table 4-41 Industrial Solid Waste Generation in BSMSN in 2040

Industry Category	Area Requirement till 2040 in Acres	NH ISW Generation ton / yr./Acres	NH Waste Generation in 2040 in Tons	Hazardous Waste ISW Generation ton / yr/acres	Hazardous Waste Generation in 2040 in Tons
Textile	2793.57	4.45	12441.00	0.00	0.00
Textile Accessary	1457.3	9.27	13511.00	0.24	354.00
Steel and Steel Product	6155.24	20.65	127092.00	0.45	2741.20
Pharmaceuticals	247	1.01	250.00	5.79	1430.00
Chemicals (Paint Industry)	187.72	1.01	190.00	2.11	395.20
Food Processing and Agro-Processing	1304.16	46.56	60720.00	6.88	8976.00
Electronic Industry	340.86	13.36	4554.00	17.81	6072.00
Automobile Industry	568.1	16.07	9131.00	3.24	1840.00
Power and Energy Industry	3025.75	5.26	15925.00	4.86	14700.00
Leather Product Industry	839.8	1.01	850.00	0.45	374.00
Light Industry (Motor cycle Assembly, Machinery Parts, General Assembly)	140.79	24.29	3420.00	2.83	399.00
Paper Board Industry	494	5.26	2600.00	1.62	800.00
Cement Industry	296.4	0.00	0.00	0.20	60.00
Chemical - Battery Industry	165.49	0.40	67.00	0.20	33.50
<b>Total</b>	<b>18016.18</b>	<b>148.62</b>	<b>250751.00</b>	<b>46.68</b>	<b>38174.90</b>



#### e. Land for Industrial Hazardous Waste Storage / Management

It has been estimated that Land required for industrial hazardous waste storage and management will be about 40 acres. Land for such activities will be selected as per DOE, GOB guidelines.

#### 4.9.7 Waste Management Approach

A two-tier approach should be thought of for waste management, I.E., (a) prevention and (b) control of environmental pollution. Prevention aims at minimization of industrial wastes at source, while the latter stresses on treatment and disposal of wastes. A schematic diagram of waste management is shown in **Figure 4-31 and Figure 4-32**.

##### a. Prevention- A Waste Minimization Approach

Reduction and recycling of wastes are inevitably site/plant specific. Generally, waste minimization techniques can be grouped into four major categories which are applicable for hazardous as well as non-hazardous wastes. These groups are as follows:

##### **Inventory Management and Improved Operations**

- Inventorisation and tracing of all raw materials
- Purchasing of fewer toxic and more non-toxic production materials
- Implementation of employees' training and management feedback
- Improving material receiving, storage, and handling practices

##### **Modification of Equipment**

- Installation of equipment that produce minimal or no wastes
- Modification of equipment to enhance recovery or recycling options
- Redesigning of equipment or production lines to produce less waste
- Improving operating efficiency of equipment
- Maintaining strict preventive maintenance program

##### **Production Process Changes**

- Substitution of non-hazardous for hazardous raw materials
- Segregation of wastes by type for recovery
- Elimination of sources of leaks and spills
- Separation of hazardous from non-hazardous wastes
- Redesigning or reformulation for products to be less hazardous
- Optimisation of reactions and raw material use

### Recycling and Reuse

- Installation of closed-loop systems
- Recycling off site for use
- Exchange of waste

Waste minimization at source may be achieved within the industry through application of various approaches described above. The systems for waste minimisation, utilisation and recycling are schematically shown in **Figure 4-33**.

#### b. Waste Management at Source

- It is possible to cut down waste generation at source by simple, inexpensive measures modifying production processes, through changes in raw materials / product design and by employing recovery / recycling and reuse techniques.
- To avoid treatment through utilization of waste, it is important from the environmental pollution view point as well as for the benefit of entrepreneurs to recycle and reuse the wastes generated by adoption of certain process change or by use of low /no-waste generation technology.
- Waste minimization can be practiced at various places in the industrial processes. More often than not, investment on waste minimization and recovery pays off tangibly within a short time.
- The initial investment for a pollution prevention project may be higher in some cases than the cost of installing conventional pollution control equipment. However, the annual operation and maintenance cost of the removal will almost always make the total cost of treatment higher than the total cost of preventive measures at sources. However, treatment and disposal of residual waste even after taking preventive measures should be given due consideration.
- Wastes from non-hazardous industries can at times produce health problems, not only among the workers and handlers of waste, but also among general population. One example of this category is the cotton dust. Cotton waste are generally non-hazardous; however, they may, in susceptible individuals provoke respiratory allergic reactions; allergy may be due to inhalation of dust containing cotton wastes or fungus or other contaminants in the waste dust.



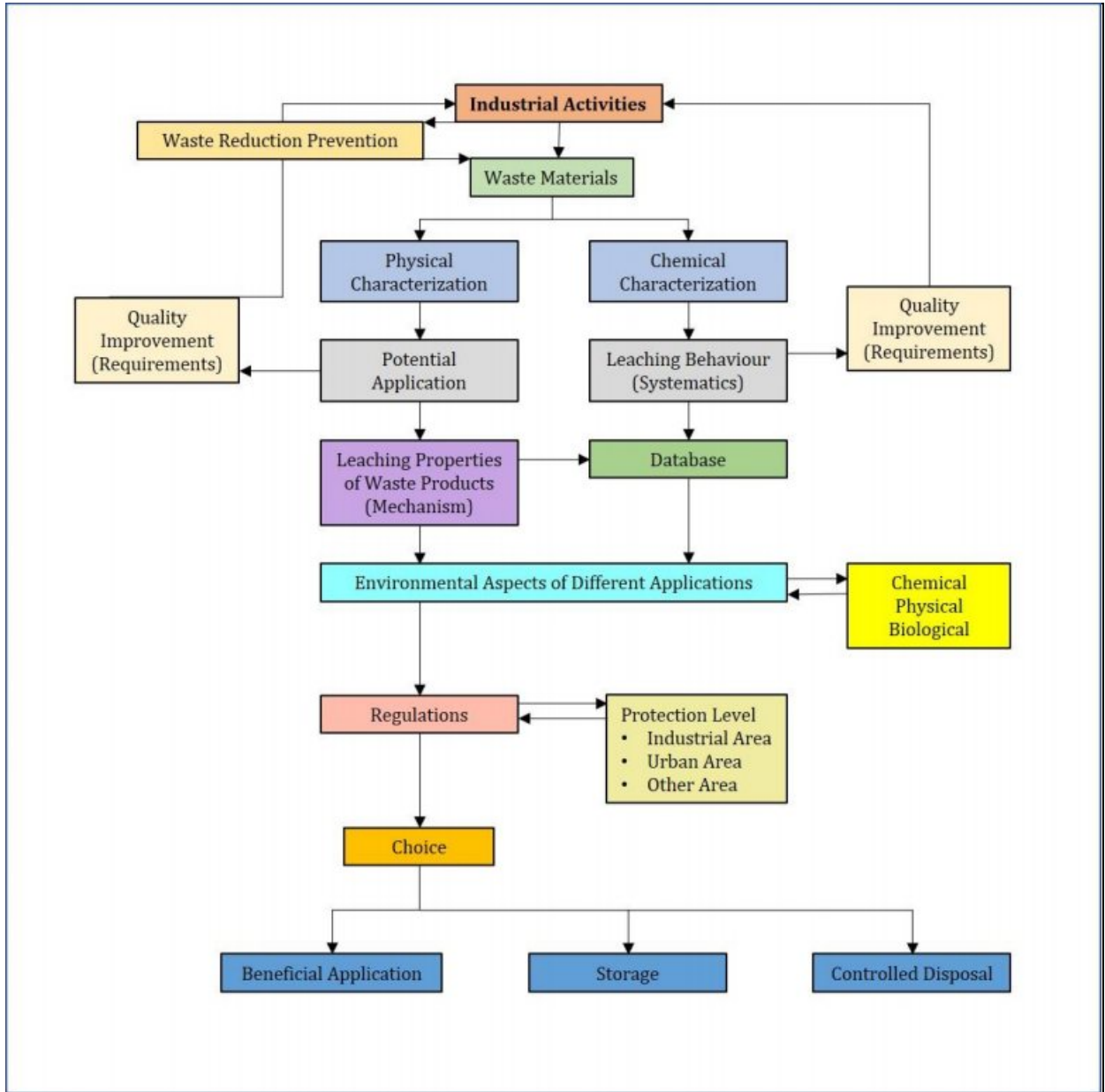

(Source: Netherlands Research Foundation)

Figure 4-31 Waste Management Approach



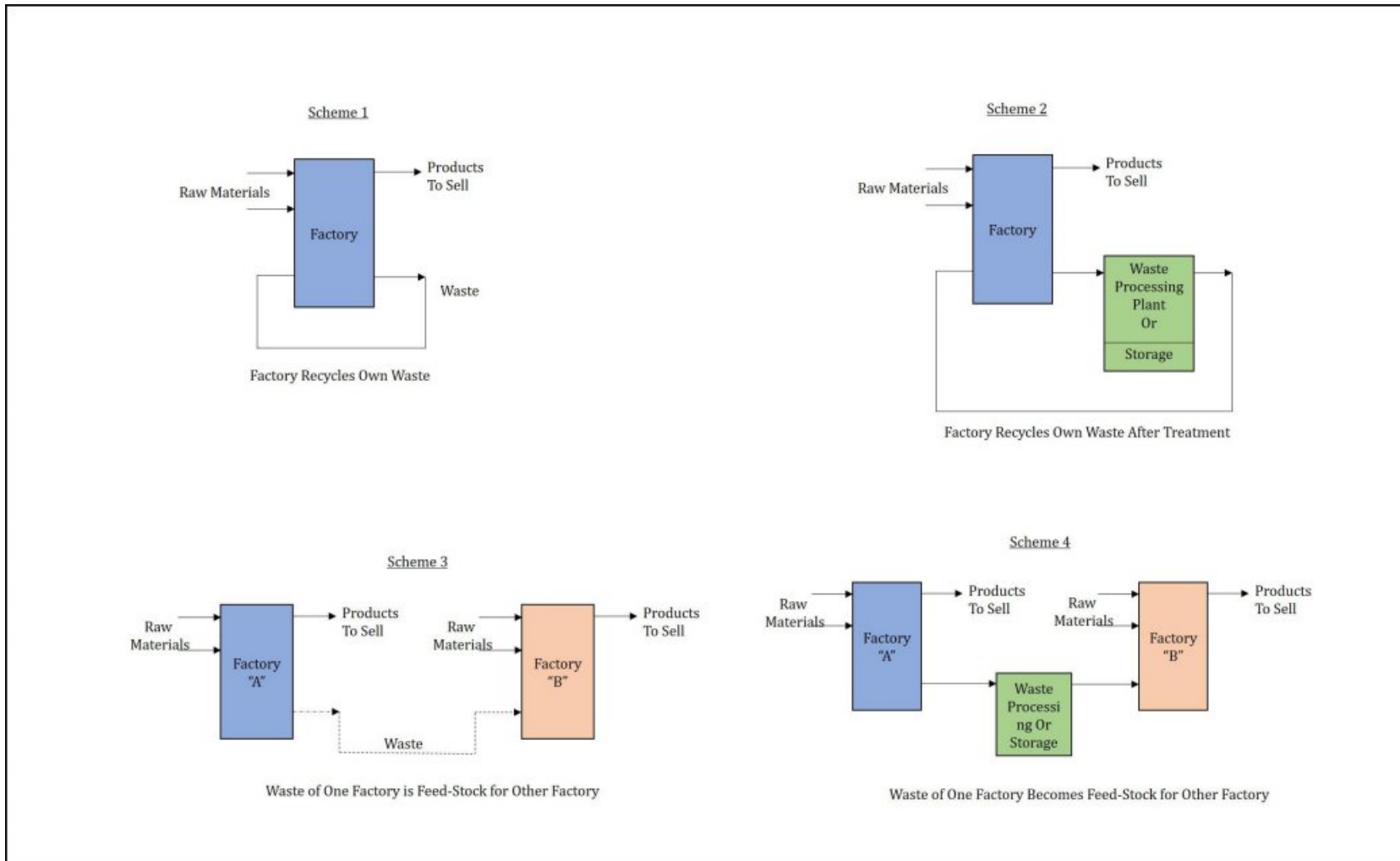

(Source: Netherlands Research Foundation)

Figure 4-32 Waste Management Scheme

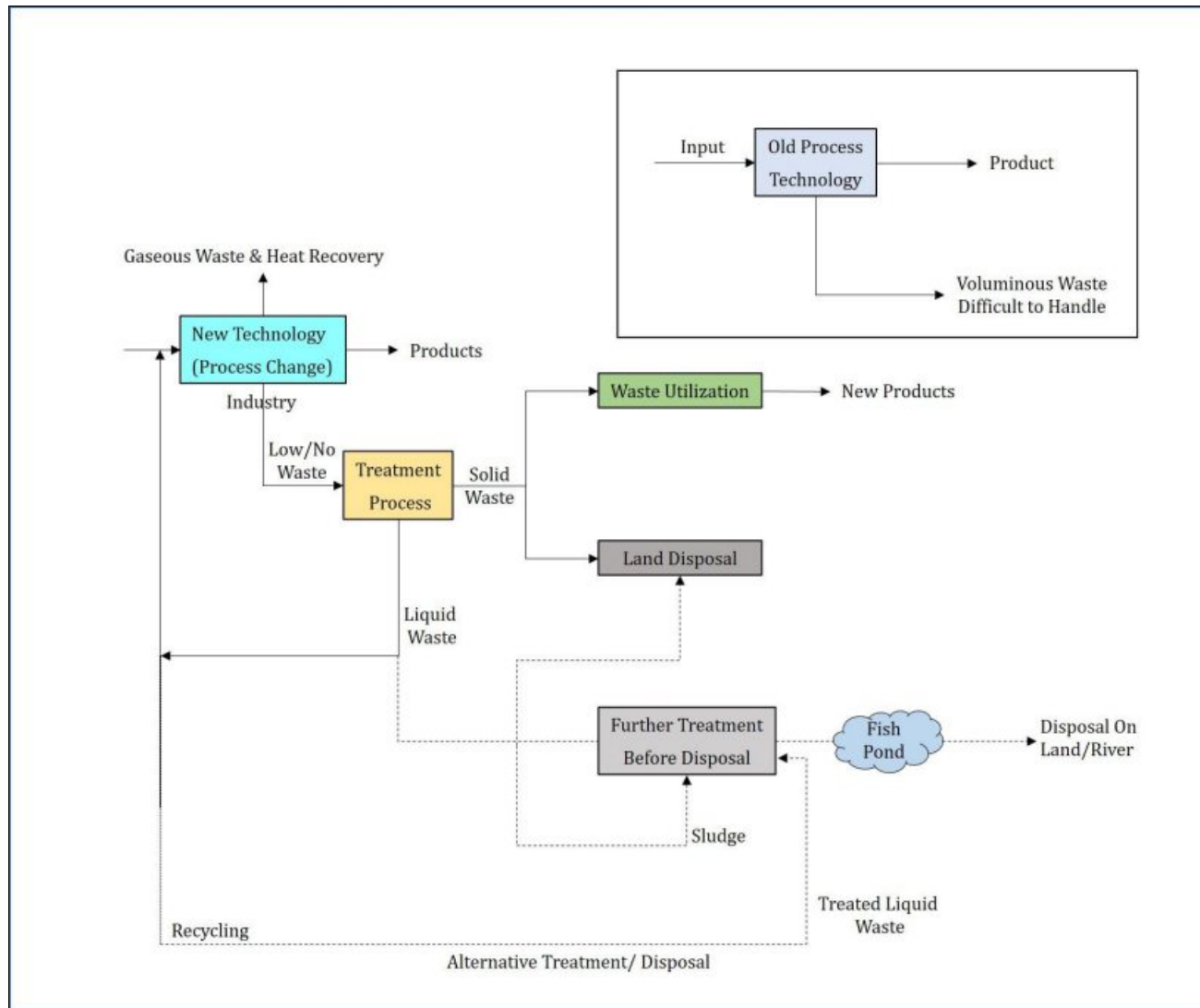

(Source: Netherlands Research Foundation)

Figure 4-33 Waste Minimization, Recovery and Utilization

## 4. Infrastructure Development Plan for BSMSN

### c. Waste Segregation

Many wastes are mixtures of hazardous and non-hazardous wastes. Much of their contents may even be water. By segregating key toxic constituents, isolating liquid fraction, keeping hazardous streams away from non-hazardous wastes, generator can save substantial amounts of money on disposal or find new opportunities for recycling and reuse of wastes. The Department of Environment, Government of Bangladesh had identified toxicity of different chemicals, through Bangladesh Standards and Guidelines for Sludge Management DOE, GOB, 2015. In Bangladesh quantum of generation of wastes (solid/liquid and hazardous/non-hazardous) for different industry has not been detailed, which is necessary for wastes exchange system or for adopting treatment/ disposal alternatives for different wastes segregated.

### d. Collection, Storage and Transport

The unsatisfactory state of storage of hazardous wastes is remedied to a large degree by such low-cost measures as restricting access, fencing off the storage area to minimize any wind-blown nuisance, providing separate covered storage for purifiable of hazardous wastes, and ensuring regular and frequent collection.

There are certain measures a municipal authority can take to control the transportation of industrial wastes, even if it does not want to become actually involved itself. For instance, contractors may be licensed after ensuring that they are technically competent and environmentally aware and should be allowed to handle industrial wastes. **Labeling and coding of hazardous waste load should be made mandatory** so that in the event of an accident, the emergency services know how to handle a spillage. If a municipal authority can also collect industrial waste; industries must pay the charge which will be based on the quantity and nature of the waste. **The principle 'the polluter pays' should be adhered to in all such cases.**

### e. Disposal Methods

Depending upon the characteristics of the wastes, different types of disposal methods can be used for hazardous and non-hazardous industrial wastes. The most predominant and widely practiced methods for wastes disposal are: (a) Landfill, (b) Incineration and (c) Composting.

### f. Landfill

The owner or operator of such facility must follow the design and operating criteria stipulated by the regulatory agencies. However, depending upon the characteristics of the waste, the landfill system with leachate collection system has to be designed with necessary facility for ground water quality monitoring.

Non-hazardous industrial waste may be disposed of along with Municipal solid waste in a scientifically developed landfill site.

The principle objective of a hazardous waste landfill is to isolate the waste materials within a confined area and prevent uncontrolled leakage of liquid contaminants. Design of the facility, therefore, requires provisions for an impermeable liner, a leachate collection and treatment system, and a suitable cover that is resistant to erosion and rainwater infiltration.

In many instances, land can be utilized in the near vicinity or on the premises of industrial companies, thereby reducing transportation costs. The potential also exists to reclaim certain areas for recreational purposes.

### g. Incineration

Depending upon the categories of waste and its potential hazards, following incineration methods may be adopted:

- Destruction of hazardous waste by thermal process using incinerator or any other method; and
- Burning of hazardous waste in boiler or in industrial furnace in order to destroy them and/or for any recycling purpose and/or energy source, which is now a general practice in Cement industry.

In Bangladesh there are very few incinerators installed on a large scale. It is important to have a central incinerator facility in the remote areas of industrial city for incinerating hazardous wastes which may be operated by a corporate body. The hazardous wastes in the industrial city to be treated can be centrally collected and transported to the facilities. In this process of central facility of treatment, the polluter has to pay for treatment facility depending on the quantity and quality of wastes generated.

In the second category of incineration, there are a number of cement industries and thermal power plants where the wastes can be burnt after considering the nature and quantity of wastes. However, in this case it is to be seen that the gaseous emission through stack does not affect the ambient air quality adversely.

#### h. Waste Manifest System

In the management of solid and liquid industrial wastes it is very important to incorporate a manifest system by which the chain responsibility of generator, carrier and receiver can be realised. This system will help the regulatory agency as nodal agency, where finally the copy of the manifest will be sent, to know whether the actual wastes generated are transported to the facilities where it is to be disposed off. In this process of waste management, all the three, **viz. pollution generator, carrier and receiver, will have to take authorisation from the nodal agency.**

EPA in 2018 has proposed hazardous waste manifest system which is designed to track hazardous waste from the time it leaves the generator facility where it was produced, until it reaches the off-site waste management facility that will store, treat or dispose of the hazardous waste.

It is recommended that in BSMSN also for the management of industrial wastes, whether they are hazardous and non-hazardous, a manifest system is framed to identify what category of waste has to be transported for disposal and treatment. BSMSN authority may adopt **Electronic Manifest (e-Manifest) System as suggested by EPA.** The schematic sketch of such a system is shown in **Figure 4-34.**



Source: EPA

Figure 4-34 Waste Manifest (e- Manifest) system

### i. Monitoring

Monitoring will tell the operating agency about the dividing line between hazardous and non-hazardous waste, about the treatability of the hazardous waste, about incompatibility of different wastes, about the performance efficiency of hazardous waste treatment and disposal facility, about the impact, about the quality of the recovered material, and about the post-closure effects if any. Monitoring gives a final signal if something is going wrong in the facility of operating agency, giving an opportunity of rectification. In consultation with the DOE, GOB the operating agency will have to draw samples of air, water groundwater, leachate waters, soils, ash, solid wastes and aesthetics. The periodicity and station selection be done carefully and the following locations might prove appropriate: -

- **Air:** upwind, downwind, three stations at 120m around the facility distance depending on stack height and location of any particular sensitive feature. This is for ambient air. Samples be selected in stack, vents and ducts.
- **Surface Waters:** upstream and downstream in the stream adjoining local nullah, upstream in the rivulet, on both the banks, upper stream and benthic deposits, and add as per sanitary survey.
- **Groundwater:** From wells specially dug one upgradient and at least three on down gradient, and deep enough. This monitoring is more significant when the groundwater is popularly used either for agricultural or personal purposes.
- **Soil:** Surrounding soil at ground level to be sampled in a circular grid.
- **Vegetative Cover:** Whether mal-effect is occurred and if yes, in what direction.
- **Biological Indicator:** By planting sensitive plants in all directions and at different distances and to note periodically as to what is the health status of each plant, providing the operating agency with information as to what further precautions are required to be taken.

#### 4.9.8 Policies to be Adopted in BSMSN

##### a. Define Waste as a Resource

Waste traditionally has been seen having no value. In a resource efficient economy and society, the term 'waste' would refer only to those residual materials that have absolutely no potential to be utilized and, therefore, economic value. Under this definition, traditionally 'valueless' streams of waste can be considered resources for a new tier of the economy. They can be recovered (or prevented from being lost) through greater efficiency and management at every stage of production and consumption. Even some hazardous or toxic materials may be recycled or re-refined for reuse.

##### b. Adoption of National 3R Policy

Waste management program are being implemented in Bangladesh through **National 3R (Reduce, Re-use and Recycle) Policy**. It has been developed with the support of United Nations Centre for Regional development (UNCRD) and Ministry of Environment of Government of Japan. Waste Concern gave technical support to prepare it. The strategy was prepared in participatory manner with series of workshops participated by all relevant stakeholders from central to grass root level. When the national 3R goal for waste management WILL BE achieved there will be complete elimination of waste disposal on open dumps, rivers, and floodplains and will promote recycling of waste through mandatory segregation of waste at source as well as create a market for recycled products and provide incentives for recycling of waste.

All in all, the 3Rs individually or collectively will save fresh resources exploitation, add value to the already exploited resources and very importantly will minimize the waste quantity and its ill effects. Waste minimization efficiency is stated to be better achieved applying 3Rs in a hierarchical order- Reduce Reuse and Recycle.

**c. Integrated Waste Management Plan**

BEZA will develop an Integrated Waste Management Plan. The primary objective of integrated waste management (IWM) planning is to integrate and optimize waste management, in order to maximize efficiency and minimize the associated environmental impacts and financial costs, and to improve the quality of life of all South Africans. The integration must be both horizontal and vertical within the government departments, as well as in other sectors and throughout the ‘waste lifecycle’. The major IWM activities are waste prevention, recycling and composting, and combustion and disposal in properly designed, constructed, and managed landfills. Each of these activities requires careful planning, financing, collection, and transport.

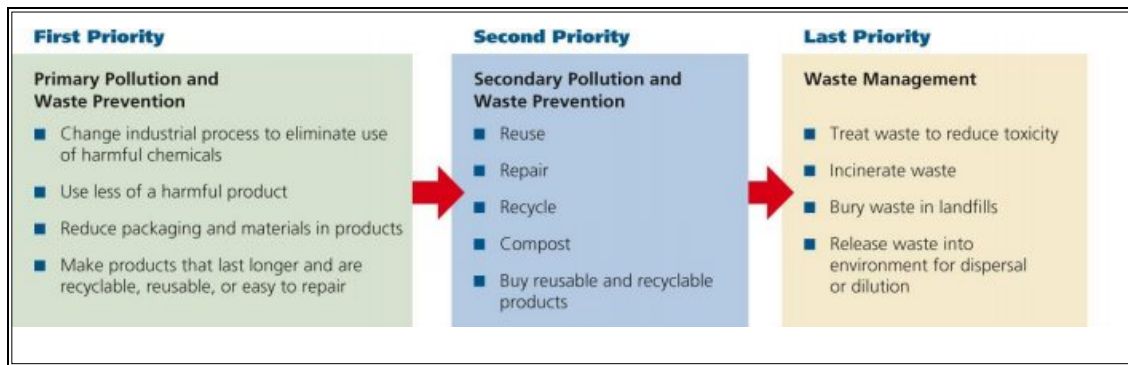

(Source: United States Academy of Science)

Figure 4-35: Priority Concept of Integrated Waste Management

**d. Compliance of International Treaties**

Since 1992, international treaty known as the Basel Convention has banned participating countries from shipping hazardous waste to or through other countries without their permission. In 1995, the treaty was amended to outlaw all transfers of hazardous wastes from industrial countries to less-developed countries. By 2010, this agreement had been signed by 175 countries and ratified by 172 countries.

Bangladesh is a signatory to Basel convention and also has accessed to this Convention on April 01, 1993. The Convention asks the signatory countries to take measures on hazardous waste management So it is evident that Bangladesh is committed to international community for taking measures on hazardous waste management within its boundary

In 2000, delegates from 122 countries completed a global treaty called the Stockholm Convention on Persistent Organic Pollutants (POPs) to control 12 POPs. Bangladesh is a signatory to this treaty.

**e. Source Separation of Waste**

Separation of waste at source is of paramount importance in 3Rs initiative. Municipal waste by virtue of its diverse sources will have mixture of materials. However, recently it is observed that recyclables with economic value such as wastepaper, plastic, broken glass, metal etc., are not segregated and disposed by people along with domestic/trade /institutional waste.



#### f. Selection of Appropriate and Affordable Technology

Development and transfer of environmentally sound technologies for waste management and the 3Rs that is applicable in the context of the prevailing socioeconomic and climatic condition of the country. Waste intensive industries may be given special attention in this context. Collaboration with materials industry is a key for technical capacity development for the 3Rs-related technologies and industries. The markets for recycled materials should be stimulated through measures such as standards, incentives, green procurement etc.

#### g. Adoption of CDM technology

CDM can promote technological improvement by encouraging energy conservation, adaptation of renewable energy, and recovery and utilization of methane from landfill, thus contributing to sustainable development in the developing countries. It can also help improve the energy supply mix, source energy supply, reduce local pollution, and help reduce GHG emissions.

Clean Development Mechanism (CDM) under Phase I of the Kyoto Protocol-the international protocol of the Framework Convention of Climate Change (UNFCCC) toward reducing GHGs. Under CDM activity a developing country can harness foreign Direct Investment from annexed developed countries in those projects where GHG emission can be mitigated.

#### h. Promote Cleaner Production

Cleaner production is the continual effort to prevent pollution; reduce the use of energy, water and material resources; and minimize waste in the production process. It involves rethinking products, product components and production processes to achieve sustainable production.

#### i. Adopt Industrial Metabolism Concept

It is an integrated collection of physical processes that convert raw materials and energy, plus labour, into finished products and wastes in a (more or less) steady-state condition. The objective of industrial metabolism in a successful industrial ecosystem is to make desired goods with the least amount of byproduct and waste.

#### j. Green Design Concept

Design for Environment considerations, which involve reducing environmental impact and resource consumption by improving product design. Design for Environment is a key component of integrated product policy, which is a policy concept to minimize environmental impacts at all phases of a product's life cycle.

#### k. Industrial Symbiosis and By-Product Exchange

**Waste is merely raw material in the wrong place', (Talbot, 1920).** Century ago, Fedrick A. Talbot in his book, Millions from Waste wrote this line." This awareness needs to be created among the industrialists, common citizens and implementing authority

This is a process of exchange and collaboration between or among firms, where one facility's waste (energy, water or materials) becomes another facility's resource. The keys to industrial symbiosis are collaboration and synergistic possibilities offered by geographic proximity. A by-product exchange will be very useful reach the limits of cleaner production. The concept of industrial symbiosis broadens the mission of such a network to sharing other resources, as well as by-products, especially energy, water and a wide range of services.

### l. Promote Green Purchasing

Industry authority needs to promote such products and services that most effectively minimize negative environmental impacts over their life cycle. It also requires manufacturers or service providers to provide information on the environmental impacts of items they offer for sale.

### m. Promote Environmental Management System (EMS) Occupational Health and Safety

Industry authority needs to promote industries within the industrial city for certification of Environmental Management System (EMS), 14001, **OHSAS 18000** and **OHSAS 45001 even for health care centers which will help in waste management and** occupational health and safety (OH and S) management.

### n. Energy Recovery in Cement Industry

- Cement kilns can be used to incinerate organic waste and toxic substances. The energy from the waste is effectively used. The wet-process cement kiln is especially well suited since it essentially consists of a large high-temperature combustion chamber and has a built-in wet and dry scrubbing system capable of removing acidic gases. Solid particles are absorbed in the kiln or precipitated in the high efficiency dust precipitators and recirculated to the kiln. Provided appropriate operating control is maintained, the quality of cement is not affected.
- The emission and emission levels are low and the destruction efficiency is very high compared to other incineration processes. The economy of using waste as fuel appears to be favorable both to the cement plant, the waste producer and the society. It generally reduces 30% to 50 % energy consumption of the cement industry

### o. Compliance with Global Issues

- At the global level, the issue of waste management, among others, has been considered by the 18th and 19th sessions of the Commission on Sustainable Development (CSD) in 2010 and 2011. The key messages and recommendations that emerged from the CSD-18 include:
- A zero waste economy, recognizing waste as a resource and waste prevention and minimization should be considered as valuable concepts to guide action on waste;
- Waste management needs to be addressed through integrated approaches;
- Reducing waste production, recycling waste and reusing materials should form the basis for sustainable waste management, and further, implementation of extended producer responsibility (EPR) should be considered;
- Emerging new waste streams such as electronic waste, plastics in the marine environment, oil and lubricants require special international and national action aiming at a high rate of recovery worldwide, and these streams need to be addressed through appropriate programs and environmentally sound technologies to promote material and energy recovery;
- Development and implementation of a national strategy for waste management is essential in order to reduce environmental, social and economic problems associated with the present disposal practices. In the past more attention had been given to waste disposal system as an end of the pipe solution with little attention to overall solid waste management. The proposed strategy is focused on the entire aspect of waste management from generation to final disposal site.

Waste minimization can be achieved in an efficient way by focusing primarily on the first of the 3Rs, "reduce," followed by "reuse" and then "recycle." The waste hierarchy refers to the "3Rs" I.E, reduce, reuse and recycle, which classify waste management strategies according to their desirability. The 3Rs are meant to be a hierarchy, in order of importance. The aim of the waste hierarchy is to **extract the maximum practical benefits from products** and to **generate the minimum amount of waste and purchasing and using resources** with care can reduce the pace of consumption of resources and further connected energy and resources, ultimately reducing wastes multi fold for waste streams.

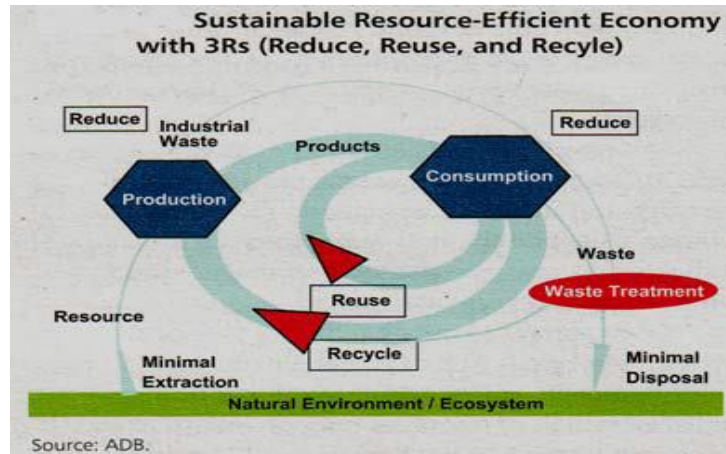

Figure 4-36: Sustainable Resource-Efficient Economy with 3Rs (Reduce, Reuse and Recycling)



(Source: EPA 2017)

Figure 4-37 Waste Management Hierarchy

- In Bangladesh the legal framework for environmental protection in general and waste management / 3R strategy in particular got a big boost from the 2011 amendment of the constitution which for the first time has created a constitutional foundation to legislation for environmental protection and management. This article states- "*Protection and improvement of environment and biodiversity - The state shall endeavor to protect and improve the environment and to preserve and safeguard the natural resources, biodiversity, wetlands, forests and wild life for the present and future citizens (Article 18A, Constitution of Bangladesh, Bangladesh Government, 2011, p. 27)*".
- This constitutional amendment was preceded by the Amendment of Bangladesh's Conservation Rules 1995 in 2010, and followed by the adoption of: i) Ship-Breaking and Recycling Rules 2011, ii)

Hazardous Waste and Ship-Breaking Waste Management Rules, both in 2011, and iii) 2013 amendment of the National Environment Policy 1992. These national level rules have mutually reinforced each other, providing an essential legal basis for implementing the 3R strategy at sectoral and local levels.

- BEZA like all institutions have to have setup for waste management. BEZA should set up two departments - one for MSW and other for Industrial waste management. This need to be considered urgently before the commissioning of the industries. There is necessity to maintain coordination among both public and private sectors to implement a waste management plan.
- **“Waste is merely a raw material in the wrong place’, (Talbot, 1920). Century ago, Fedrick A. Talbot** in his book, ‘Millions from Waste’ wrote this line. To utilize this raw material awareness has to be created among the stakeholders.
- BEZA will ask each and every industrial entrepreneur to submit their waste management plan along with their project report before allotting land to the entrepreneur. The authority should monitor the approved waste management plan regularly.
- DOE, GOB will ask each and every industrial entrepreneur to submit their waste management plan along with their IEE / EIA report before granting Environment Clearance (EC) to the entrepreneur and should monitor the approved waste management plan regularly.
- As National 3R Strategy for Waste Management, 2010 launched in Bangladesh. The City Corporations and Municipalities are making efforts to incorporate the concepts and guidance of this Strategy in their solid waste management activities. However, there have been dedicated pilot initiatives in line with 3R strategy through different programs and projects being implemented by various Ministries/Divisions/Agencies. Industrial management authority should take active participation in such pilot project to establish a land mark in waste management.
- The GOBs National 3R Policy Program has been introduced at the domestic level. But no effective initiative is observed in the production sector, industry, commerce and property consumption. The industrial city authority should go beyond the concept and try to implement **4R (Reduce, Re-use, Recycle and Recovery)** as adopted in Solid Waste Management Action Plan for Eight Secondary Towns in Bangladesh 2005 which will be more effective from 3R.
- Unabated proper Waste management in cities and industrial zones is creating environmental degradation which has far-reaching effects on both the physical and mental health of the people as well as implications on the future economy of the country. To say the least, environmental pollution of waste practice is in a deplorable state. Volume of waste products will also increase due to increased urbanization and industrialisation.
- **If effective steps are not taken from the beginning then in long run the whole BSMSN and the surrounding environment will be polluted and BSMSN will lose its identity as Green Economic zone / Sustainable industrial city.** The authority should deal with the management program more importantly both policy including formulation and implementation level and administrative level including management, monitoring and enforcement of law. Beside this, adequate manpower and

budget, modern technology, adequate number of transports and dustbins are necessary in the management level.

- Most of the developed countries in Europe, Australia and USA have proper regulatory background for Industrial Waste Management (IWM) as well as in some Asian countries like Malaysia and Japan (waste policy of Norway, 2009; Ireland waste management act no 566, 2009; Japan waste management and public cleaning law no.66, 2001). It is evident that most of the industrialized countries have established proper legal framework for IWM. In addition, most countries follow some concepts, strategies and models for industrial waste management in industrial parks. Among these **polluter pays principle** is enacted to make the party responsible for producing pollution and paying for the damage accrued to the natural environment. Most polluters are not paying unless forced by the government intervention (Economic Co-operation and Development, 2006). **Pay As You Throw (PAYT)** is another strategy which use-pricing concept for disposing of industrial waste where users in industrial parks are charged on a rate based on how much waste is generated for the collection of the municipality or local authority., PAYT must integrate with regulations of the country's and financial mechanism of the companies to be effective. Similarly, the principle of reducing, reusing and recycling resources and products is often called the **"3Rs" is the common platform** for management of waste. In the National 3R strategy for waste management, Bangladesh, (2009) also emphasized that, implementation of the 3R strategy involves active participation of major stakeholders in industrial areas or in industrial parks such as government, citizens and industrialists, private sector, informal sector, media and small and medium enterprises in their respective roles.
- It is recommended that BSMSN (Industrial city) authority adopt international waste management practices i.e. Integrated Waste Management strategy based on – **3R (Reduce, Re-use and Recycle) / 4R (Reduce, Re-use, Recycle and Recovery)**.
- **For BSMSN, BEZA should adopt a 5R Policy (Re think, Reduce, Re-use, Recycle and Recovery)**

#### Suggestions for Action

- Create awareness among the citizens.
- Create responsibility among the concerned authority.
- Use modern technology.
- Make a Committee at ward level and establish of strong collaboration and partnership among various stakeholders.
- Low Cost in management.
- Create a movement for mobilization.
- Impart education and training.
- Enact law and carry on monitoring.
- Advocacy for public awareness, motivation on different aspects of waste management.
- Encouragement for recycling of waste materials.
- Develop Sewage and industrial waste treatment plants.
- Develop a sustainable waste management Policy.

#### 4.9.9 Cost Estimations of Solid Waste Management in BSMSN

Cost estimations for solid waste management within BSMSN has been projected as:

Table 4-42 Cost Estimation of Solid Waste Management

Description of Item	Quantity/ Units	Price Without Tax		Phase I Cost Breakdown (Years 1-5)		Phase II Cost Breakdown (Years 6-10)		Phase III Cost Breakdown (Years 11-15)	
		(In Million Taka)	(In Million USD)	(In Million Taka)	(In Million USD)	(In Million Taka)	(In Million USD)	(In Million Taka)	(In Million USD)
		Solid Waste Management	142.5 acres	1884	22.17	328.95	3.87	1156	13.6
Engineering Fees (5%)		94.2	1.1085	16.4475	0.1935	57.8	0.68	19.9975	0.235
Contingency (15%)		282.6	3.3255	49.3425	0.5805	173.4	2.04	59.9925	0.705
Taxes (18%)		339.12	3.9906	59.211	0.6966	208.08	2.448	71.991	0.846
<b>Total</b>		<b>2599.92</b>	<b>30.594</b>	<b>453.95</b>	<b>5.340</b>	<b>1595.2</b>	<b>18.76</b>	<b>551.931</b>	<b>6.486</b>

#### 4.10 Summary of Cost Estimations for the BSMSN Project

The total project costs for BSMSN is estimated at 2,973 billion BDT. For further detailed cost estimations, see **Annexure 4.10**.

Table 4-43: Summary of Cost Estimations for the BSMSN Project

Description of Items	Total Costs	
	(In Million Taka)	(In Million USD)
<b>Off-Site Costing</b>		
Highway Improvements	39606	466
Rail Station Expansion/Improvements	2760	33
Rail Extension/Light Rail Expansion	121992	1435
Road Network Improvements from Highway to BSMSN Boundaries	85146	1002
Electricity Network Transmission	6016.11	70.77776
Water Network	20433.8	240.4
<b>Off-Site Total</b>	<b>275953.91</b>	<b>3247.178</b>
<b>On-Site Costing</b>		
Resettlement Costs	598.07	7.036151
Cut and Fill	1951340	22956.94
Embankment	6292.8	74.03294
Road Network	203067	2389
Electricity Network	288106	3389.48
Water Network	71201.2	837.8
Storm water Drainage System	101652.3	1195.9
Wastewater Handling System	51084.2	601
Gas Network	21716.73	255.4909
Solid Waste Facility	2599.92	30.5946
Plantation	107.767	1.267846
<b>On-Site Total</b>	<b>2488223.19</b>	<b>29273.57</b>
<b>Grand Total Project Costs</b>	<b>2973719.615</b>	<b>34985.72</b>



***5. Social Issues within  
BSMSN***





## 5. Social Issues within BSMSN

This section highlights social aspects and resettlement issues which are crucial in the planning and implementation of BSMSN project.

### 5.1 Background Analysis

BSMSN project requires land acquisition that will lead to loss of property, home and livelihood sources of the settlers already living there. Social and the resettlement issues have been addressed in BSMSN Master Plan to mitigate the impact resulting from the acquisition of the proposed site and its adjacent areas which are mainly based on the current socio-economic scenario of the locality. Consideration has also been given taking into account on how the proposed BSMSN project will affect lives, livelihoods, structures, institutions, historic sites, ethnic and religious minorities and the resettlement of the displaced population. It is understood that these activities are likely to have positive impact on the poverty issues, food security, economic status, livelihood, social status, and gender relations.

### 5.2 People and Structures Likely to be Affected in BSMSN

#### 5.2.1 Finding on Off-Site Area

Although there are several institutions, structures and settlements in the Sonagazi, Mirsarai and Sitakunda Upazilas, the BSMSN area is mostly located in vast government khas land. However, additional land acquisition will be needed for the widening or for upgrading of approach roads to connect the BSMSN with the Dhaka-Chattogram Highway, to ensure efficient and smooth communication. It has been found from the survey that most of the lands along proposed approach roads are currently being used for agriculture including a few homestead and shops. Details of affected structures along the proposed approach roads to the BSMSN have been presented in **Table 5-1. Annexure 5.1** shows the list of people to be affected.

Table 5-1: Information on Approach Roads to BSMSN

Sr. No.	Road Name	Starting and Ending Point	Residential Structures	Commercial Structures	Others	Remarks
1.	<b>Feni-Sonagazi Road</b>	Lalpol intersection at Dhaka-Chattogram Highway to Sonagazi "0" point	Total-61 (Pucca-8, semi-pucca-5, katcha-48)	Total-60 (Pucca-50, semi-pucca-50, katcha-500)	<ul style="list-style-type: none"> <li>School/ Madrasa-8</li> <li>Mosque-5</li> <li>Hospital-3</li> </ul>	In future, RHD may construct this road
2.	<b>Sonagazi-Muhuri Project Road</b>	Sonagazi "0" point to Muhuri Project	Total-95	Total-550		In future, RHD may construct this road
3.	<b>Muhuri Project Road</b>	Zorarganj Bazar intersection to Muhuri Project	Total-35 (Pucca-10, katcha- 25)	Total- 180 (Pucca-80, semi-pucca-50, katcha-50)	<ul style="list-style-type: none"> <li>School/ Madrasa-3</li> <li>Mosque-7</li> <li>Mondir-1</li> <li>Graveyard-4</li> <li>Small Mill-2</li> </ul>	In future, LGED may construct this road
4.	<b>Bamonsundar Road</b>	Starting from Mithachara intersection to the end point of the road	Total-60	Total-120	<ul style="list-style-type: none"> <li>School/ Madrasa-3</li> <li>Mosque-2</li> </ul>	In future, LGED may construct this road
5.	<b>Sheikh Hasina Saroni</b>	Borotakia intersection to Bamonsundar intersection/CP mor point	It has already under construction for 4-lane road			Development ongoing by RHD

Sr. No.	Road Name	Starting and Ending Point	Residential Structures	Commercial Structures	Others	Remarks
6.	<b>Barodarogarh at-Mohanagar Road</b>	Barodarogarhat intersection to Habib road intersection	Total-80	500	<ul style="list-style-type: none"> <li>School/Madrassa-8</li> <li>Mosque-5</li> <li>Hospital-3</li> </ul>	In future, LGED may construct this road
7	<b>North to SHS</b>	North road of Sheikh Hasina Saroni	Total-225 (Pucca-41, semi-pucca-42, katcha-142)		<ul style="list-style-type: none"> <li>Mosque-1</li> <li>Mazar-1</li> </ul>	
8	<b>South to SHS with railway</b>	South road of Sheikh Hasina Saroni	Total-177 (Pucca-20, semi-pucca-35, katcha-122)		<ul style="list-style-type: none"> <li>Madrassa-1</li> <li>Primary School-1</li> <li>Mandir-1</li> </ul>	

Source: Socio-economic survey, 2018,2020

### 5.2.2 Findings for On-Site Area

The proposed BSMSN is mostly a barren land having very negligible human activities. As a handful of families live there, the number of households to be affected by the proposed Bangabandhu Sheikh Mujib Shilpanagar will be very low. BEZA with the support by World Bank, has already compensated 14 Project Affected Households (PAHs) living in CP Intersection and Mirsarai site of the BSMSN (Western portion of the Sheikh Hasina Saroni and north from CP intersection). The detail list of affected households is given at **Annexure 5.1**

### 5.3 Social Impact and Mitigation

Though Sonagazi, Mirsarai and Sitakunda are large Upazilas, the present concentration and density of the population in the BSMSN is very low. Besides, population density along the proposed approach roads of BSMSN is significantly low. Thus, it seems that the overall positive impact is expected to be high in comparison with displacement and related problems. However, regarding the social indicators, the following are likely to impact the social lives of the local population due to BSMSN:

Table 5-2: Social Issues, Their Impacts and Strategies for Risk Mitigation

Sl. No.	Issues	Impacts	Strategies for Risk Mitigation
1.	Poverty Alleviation and Diversification in Livelihoods	Vast employment opportunities will be created by the BSMSN which will reduce poverty through the increased employment and income from various livelihood options. By means of industrialization and related trades, diversification of livelihood will occur for all strata of people. About 1.01 million employment opportunity is likely to be created by the BSMSN industries and other institutions. Besides, significant number of indirect employment opportunity will be generated which will not only alleviate the poverty but will also change the livelihood pattern of the local people.	Skill development training programs by relevant government agencies and NGOs will be needed for efficient utilization of this huge manpower.
2.	Food Security	As it is expected that the household income will increase due to BSMSN, the families will be able to ensure food security. Generally, the small landowners are not be able to cover their food security by their production. As these earning is not enough for the small farmers, seasonal workers, they will be able have a better livelihood and secure earning options to ensure food security with a standard livelihood using the opportunities created by BSMSN.	As agricultural lands will be acquired, special care are needed for the small and marginal farmers who are solely or mainly dependent on these lands. Better livelihood options and food security should be ensured for them.

Sl. No.	Issues	Impacts	Strategies for Risk Mitigation
3.	Awareness and Accessibility Regarding Health	It is expected that better and affordable health facilities will be accessible to the locality as there is provision of better and improved health facilities in BSMSN. Besides, provision of ETP in heavy industrial zone will reduce both the environmental and health hazard.	Issue of health hazards caused by the Bangabandhu Sheikh Mujib Shilpanagar industries need to be identified. If there are any, steps need to be taken to prevent and minimize such hazards.
4.	Education for Children Including Girls' Education	Due to the establishment of the BSMSN and positive economic changes in the locality, the education rate is likely to increase leading to a reduction in children's informal or agriculture-based labor. Girl education will also be positively impacted.	During construction and while the BSMSN gets operational, children's safety needs to be ensured. Local community needs to be sensitized and NGOs can be engaged with them.
5.	Access to Civic Amenities and Communication	Development of BSMSN will ensure better livelihood and increase the opportunity to access better civic facilities.	
6.	Social Mobility	With improved employment opportunities and higher and secured income, impoverished people will be able to move up the social ladder.	
7.	Women's Employment	Presently, women are mostly engaged in household works. The employment opportunities created by the proposed BSMSN for women will directly or indirectly will lift their socioeconomic status. Through employment, women can contribute jointly with male to change and upgrade the livelihood pattern of the family.	Measures should be taken to allocate significant percentage of job opportunity for women in BSMSN.

### 5.3.1 Resettlement Issues and Plan

Resettlement Plan (RP) is required to deal with social safeguard issues and impacts expected to arise due to development of BSMSN. The adverse impacts are associated with the acquisition of private lands, and resumption of public lands that have been under various uses by non-titled persons / households. The recommended policy objective conforms to the Government's policy to reduce poverty and meet the Sustainable Development Goals (SDGs). The basic plan is to avoid land acquisition as much as possible. The guiding principles are:

- To minimize and mitigate adverse impacts
- To ensure compensation payment according to the World Bank OP 4.12 and GoB rules and regulations
- To establish a grievance redress mechanism with representatives from stakeholders to suggest institutional and monitoring arrangement for compensation payment

The private home owners who will lose their homes will be placed in the resettlement area in BSMSN. Private land owners of agricultural lands, ponds and owners of shops will be compensated according to standard provisions. As the BSMSN will provide job opportunities and better wages, the poor population will be benefited. The BSMSN will ensure that the affected agricultural landowners and laborers are given priority in employment and recruitment in BSMSN.

To address the resettlement issue, four resettlement sites namely RS1, RS2, RS3 and RS4 have been provided in BSMSN (**Figure 5-1**). RS1 is located in Precinct A in Char Khondakar mouza in Sonagazi thana of Feni zila with an approximate area of 13.19 acres of land. Whereas, both RS2 and RS3 are located in Precinct D and Precinct F in Purba Ichakhali mouza of Mirsarai thana with an approximate area of 21.71 acres and 21.39 acres of land respectively. RS4 is located in precinct B.

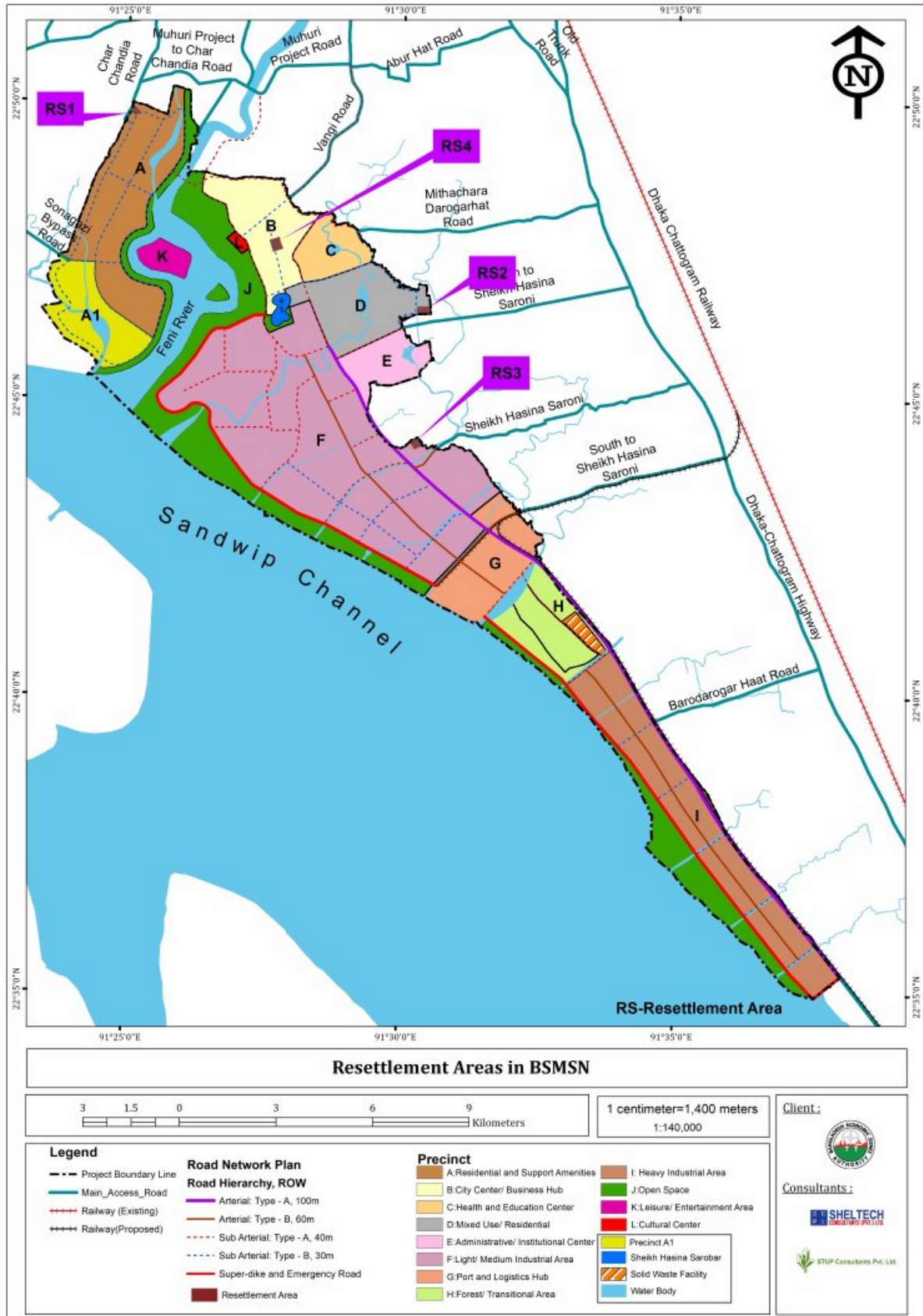

Figure 5-1: Resettlement Areas in BSMSN

## 5.4 Corporate Social Responsibilities (CSR) Activities

Projected employment within BSMSN will be approximately 1.1 million in 2040. In addition to the formal sectors, an informal sector is also expected to be grown and create significant number of employments which is estimated to be 15% of direct and indirect employment. Indirect employment is estimated to be 25% of the direct employment. It is expected that these employment generation will contribute to poverty reduction, reducing hunger and reduce gender gap in labour force, thus will contribute to achieve several SDG goals. On the contrary, as some people will be displaced including women and children and new workers coming from all over the country will need healthy social atmosphere and services for a better living.

Some CSR activities are expected to be taken under consideration. The following section presents recommended CSR activities in BSMSN.

*Table 5-3: Recommended CSR Activities*

SN	Required Activities/Actions	Target Groups
1.	Need based training in localized center and factory	Women
2.	Agriculture development training center, agricultural product sale center or market	Farmer
3.	Animal farming training center and technical support services provider organization.	Farmer, women, youth
4.	Micro credit or loan provision support service on easy terms for the entrepreneurs	Female, youth
5.	Ensure education institutes like Schools, vocational education	All age group population
6.	Modern general and specialized medical services	All types of Residents, workers, women, children
7.	Establishment of good communication network	Workers, entrepreneurs, women, youth, children and disabled group
8.	Union level community center, clubs to arrange occasional program for social activity like national and international special day program, development related training and workshop program etc.	All types of population
9.	Agro based small industry and business-like micro enterprise support service including financial loan.	Women, youth, entrepreneurs
10.	Fisheries training and technical support services center	FGD, Fishermen, youth, women
11.	Fish sale center, storage, ice factory and processing facility like support services for the entrepreneurs.	Fishermen, entrepreneurs
12.	On job training center for skilled manpower development among and beyond the current workers	Men, women, youth
13.	Technical education center like diploma or vocational institute	Youth, Women
14.	'One house -one farm with small yard' for affected homeless or land less family.	Agricultural day laborer, women
15.	Youth and Women's club and information center	Women, youth
16.	Community Library and information center	Youth, children, women
17.	To ensure safe water for all affected people by community management by engaging LGI	Community
18.	To support old aged citizen (>65 year) among the affected people ensure LGIs to include them in social safety nets.	Old aged citizen
19.	Providing need based training for getting job opportunity in the BSMSN or expanding service sectors. Utilizing current training centers or alternatively establishing a multipurpose training center.	Women and youth.
20.	Sponsor various sports and gaming activities such as Cricket, Football, Badminton etc. leagues through District Sports Council	Youth, children

SN	Required Activities/Actions	Target Groups
21.	Establishment of religious institutions within the vicinity	All population
22.	Community based fish cultivation by engaging women and fishermen families by providing easy technology fish farmers.	Women, youth, fishermen
23.	Donation of ambulances to Upazila Health Complexes with ICU facilities to deal with emergency patients, maternity health and occupation health hazards.	Women, children, old age population
24.	Preschool facilities for the children of displaced families with providing tiffin support to the students. Providing logistical supports by supplying benches, ceiling fans etc. to the schools by engaging LGIs and NGOs and recreational place, parks etc.	Children
25.	Contribute to the social forestry program by providing fund to the Forest Department and planting trees around the project area Provide financial incentives of share of tress to protect the social forestry from being grabbed or destruction for livelihood.	Community people, women
26.	Formulate a recruitment policy giving priority to PAPs and locals	Youth, women, all workers
27.	To develop and ensure a welfare policy for the affected people to get social support properly.	All PAPs

## ***6. Annexure***





# Annexure

## Annexure 3.1: Analysis of Flood and Seismic Resilience of Flood Protection and Management Infrastructure and Site Development

Infrastructure Type	Specifications	Risk Management Level	Validity of Existing Disaster Risk Management Level	Additional Measures and Considerations to Enhance Resilience
Coastal Embankment	<b>Flood Crest Elevation:</b> MSL <sup>27</sup> +9.0 m	<b>Coastal Flood Risk Level:</b> High Risk Management level-100-year return period coastal flood <sup>28</sup>	<p>The design flood level was determined based on frequency analysis using the years (2010-2017) of recorded water level at Karnafuli Station.</p> <p>Additional components such as: tidal surges, wind set-ups, waves, and subsidence, as well as, a freeboard were considered.</p>	<p><b>Additional information that could enhance coastal flood resilience analysis of existing structure:</b>            Exact location of the Karnafuli observation Station</p> <p><b>Recommended additional structural measures:</b>            Cover the entire dyke with concrete blocks, geotextile, etc.            Place additional blocks along the dyke toe to protect from scouring in case of overtopping.</p> <p>Monitor the movement of the random blocks (W=1.2t). If movements are excessive, replace with larger blocks (W&gt;3t).</p> <p><b>Recommended additional soft measures:</b>            To collect accurate and detailed sea level data for OandM and future development, tide gages should be installed.</p> <p>Validate the design flood level based on the additional information collected from installed gages.</p> <p>To train firefighters for flood fighting activities. (IE. Installation of temporary barriers and manage seepage in case of high-water level situations.)</p>
	<b>Earthquake:</b> n/a	<b>Seismic Risk Level of Site:</b> Moderate Risk	Due to lack of geo-technical information of the fill material and	<p><b>Additional information that could enhance seismic resilience analysis of existing structure:</b></p>

<sup>27</sup> Equivalent to PWD/PWDB which is the datum used by the Bangladesh government set by the Public Works Department

<sup>28</sup> Source of Information: Technical Discussion with China-Harbor and China Civil Engineering Construction Corporation

Infrastructure Type	Specifications	Risk Management Level	Validity of Existing Disaster Risk Management Level	Additional Measures and Considerations to Enhance Resilience
		(Seismic coefficient = 0.2)  <b>Risk Management Level:</b> 2475-year return period event <sup>29</sup>	existing soil, it is difficult to validate the seismic resilience of the dyke against slope failure and liquefaction.  Nonetheless, due to the site development level being set at 6.5 meters above mean sea level, even if the coastal dyke was to collapse due to an earthquake event, storm surge up to 6.5 meters could still be managed without causing inundation to the industrial zone.	Collection of geotechnical data  Result of slope stability and liquefaction analyses  Depth of PVD installed on site  <b>Recommended additional measures:</b> Conduct monitoring on the movement of the dike structure by installation of movement sensor, regular survey, and observation via satellite data (IE. SAR data).
River Dyke	<b>Flood Crest Elevation:</b> MSL+8.0 m	<b>River Flood Risk Level:</b> Moderate  <b>Management Level:</b> 25-year return period river flood <sup>30</sup>	Due to lack of information regarding water levels (from Feni River, Icchakhali Channel, etc.) and frequency analysis methodology, it is difficult to validate whether MSL+8.0 m crest height of the river dyke can provide protection against 1 in 25-year river flood.  However, based on water level information and frequency analysis used for the super dyke, the design water level without considering freeboard is still 7.5m, less than the height of the river dyke.	<b>Additional information that could enhance flood resilience analysis of existing structure:</b> Engineering basis for the selection of the management level as 25-year return period.  Historical water level observation data from Feni River, Icchakhali Channel, etc., and the frequency analysis methodology.  Engineering design basis for the non-installation of PVD in many upstream sections along the river dyke.  <b>Recommended additional measures:</b> Area wide river flood risk analysis and management plan considering the effects of the present and future development is necessary.  Study on river/channel improvement including the design of the regulator, installation of pumps, or provision of diversion channels, considering future development is necessary

<sup>29</sup> Source of Information: Bangladesh Building Code

<sup>30</sup> Source of Information: Technical Discussion with China-Harbor and China Civil Engineering Construction Corporation

Infrastructure Type	Specifications	Risk Management Level	Validity of Existing Disaster Risk Management Level	Additional Measures and Considerations to Enhance Resilience
	Earthquake: n/a	<p><b>Seismic Risk Level of Site:</b> Moderate Risk (Seismic coefficient = 0.2)</p> <p><b>Risk Management Level:</b> 2475-year return period event<sup>31</sup></p>	<p>Due to lack of geotechnical information of the fill material and existing soil, it is difficult to validate the seismic resilience of the dyke against slope failure and liquefaction.</p> <p>Nonetheless, due to the site development level being set at 6.5 meters above mean sea level, even if the river dyke was to collapse due to an earthquake event, river flood up to 6.5 meters could still be managed without causing inundation to the industrial zone.</p>	<p><b>Additional information that could enhance seismic resilience analysis of existing structure:</b> Collection of geotechnical data.</p> <p>Result of slope stability and liquefaction analyses.</p> <p>Depth of PVD installed on site.</p> <p><b>Recommended additional measures:</b> Conduct monitoring on the movement of the dike structure by installation of movement sensor, regular survey, and observation via satellite data (I.E. SAR data).</p>
Stormwater Drainage	<p><b>Floods Maximum Design Capacity of Drainage Management:</b> 110 mm / hour<sup>32</sup></p>	<p><b>Risk Management Level:</b> ~5-year return period<sup>33</sup></p>	<p>Due to lack of information regarding the design basis, it is difficult to validate the existing drainage design.</p> <p>Nonetheless, the outfall is situated higher than the historical maximum water levels, so drainage can still facilitate even under flood situation.</p>	<p><b>Additional information that could enhance flood resilience analysis of existing structure:</b> Rainfall analysis and drainage design report containing design basis, rainfall, return period, etc.</p> <p><b>Recommended additional measures:</b> Provision of flap valves/gates at the outlet to prevent backflow in case of high-water level along the river/channel.</p> <p>Equipment of mobile pump in case of emergency situation.</p>
	<p><b>Earthquake:</b> Open channel design<sup>34</sup></p>	<p><b>Seismic Risk Level of Site:</b> Moderate Risk (Seismic coefficient = 0.2)</p>	<p>In general, drainage structures are small that seismic analysis is not</p>	<p><b>Recommended additional measures:</b> The open channel can be easily maintained but for the underground drainage components, such as the drainage route from the tenant</p>

31 Source of Information: Bangladesh Building Code

32 Source of Information: Assumption based on the calculation files provided by the consultant through World Bank

33 Source of Information: Based on the document published by Bangladesh University of Engineering and Technology; Pourashava, Mimensingh uses a 5-year return period for all types of drains

34 Source of Information: Based on the drawings provided by the consultant through World Bank

Infrastructure Type	Specifications	Risk Management Level	Validity of Existing Disaster Risk Management Level	Additional Measures and Considerations to Enhance Resilience
		<b>Risk Management Level:</b> 2475-year return period event <sup>35</sup>	needed. <sup>36</sup> In case of damages, the cost of repair is not significant.  However, due to the lack of information of geotechnical data, the risk of liquefaction cannot be discounted.	to public drainage, seismic resilient measures like earthquake-resistant joint can be utilized.
Site Development	<b>Floods</b> <b>Initial average ground level:</b> MSL +4 m  <b>Elevated Ground Level After Site Development:</b> MSL+6.5 m	Historical maximum water level at coast and river <sup>37</sup>	The height of the site is above the historical maximum water level at the site, recorded over 8 years.	<b>Recommended additional measures:</b> Differential settlement should be well monitored during the construction to avoid local inundation within the EZ.
	<b>Earthquake:</b> N/A	<b>Seismic Risk Level of Site:</b> Moderate Risk (Seismic coefficient = 0.2)  <b>Risk Management Level:</b> 2475-year return period event <sup>38</sup>	Due to lack of geotechnical information of the fill material and existing soil, it is difficult to validate the seismic resilience of the site against liquefaction.	<b>Additional information that could enhance seismic resilience analysis of existing structure:</b> Collection of geotechnical data.  Result of liquefaction analysis.  <b>Recommended additional measures:</b> Conduct monitoring of settlement.  Provide subsidy for the soil improvement or use of pile foundation for building construction within the EZ.

(Source: Yachiyo Engineering Company, 2020)

<sup>35</sup> Source of Information: Bangladesh Building Code

<sup>36</sup> In a case study in Japan, during the Great East Japan Earthquake 2011, drainage channels affected by the earthquake were displaced but didn't collapsed and could still facilitate the flow of water (<https://www.maff.go.jp/j/council/seisaku/nousin/gizyutu/h24-2/pdf/ref-data2-6.pdf>)

<sup>37</sup> Source of information: Based on the calculation files provided by the consultant through World Bank

<sup>38</sup> Source of Information: Bangladesh Building Code (BNBC, 2015)

### Annexure 3.2: Infrastructure Resilience and Performance Enhancement Measures

Stage	Resilience Measures	Performance Enhancement	Costs	Savings
<b>Coastal Embankment and River Dykes</b>				
<b>Design</b>	-Meet international standards and apply higher demand.	-Longer service life and higher capacity.	Medium	High
<b>Construction</b>	-Ensure proper quality control of construction.	-Prevent adverse effects during heavy flooding.	Medium	Med
<b>Maintenance</b>	-Develop enhanced maintenance plan.	-Maintain extend service life.	Low	Med
<b>Monitoring</b>	-Develop real-time monitoring network and warning system.	-Reduce impacts of heavy flooding on people and facilities.	Medium	Low
<b>Response</b>	-Develop flood hazard map and response protocol.	-Mitigate damage, prevent secondary impacts and expedite recovery.	Low	Low
<b>Pumps and Gates</b>				
<b>Planning</b>	-Apply higher demand.	-High capacity for unexpected heavy rainfall and flooding.	Medium	High
<b>Design</b>	-Meet international standards.	-Longer service life and more robustness.	Medium	High
<b>Construction</b>	-Apply cement grouting or soil compaction.	-Strengthen and improve soft and liquefiable soil.	Medium	High
<b>Maintenance</b>	-Develop operation maintenance plan.	-Maintain expected water discharge, extend service life.	Low	Med
<b>Monitoring</b>	-Develop real-time monitoring system for WL and flooding.	-Reduce impacts of heavy rainfall and flood on people and facility.	Medium	Low
<b>Stormwater Drainage</b>				
<b>Planning</b>	-Meet international standards and apply higher demand.	-Longer service life and higher capacity.	Medium	High
	-Control water discharge flow.	-Prevent adverse effect during heavy rainfall and flooding.	Low	Low
<b>Design</b>	-Build retention pond, reservoir or underground storage.	-Store excess water during heavy rainfall and flooding.	Medium	High
<b>Maintenance</b>	-Develop an enhanced maintenance plan.	-Maintain expected water discharge, extend service life.	Low	Med
<b>Monitoring</b>	-Develop real-time monitoring network and warning system.	-Reduce impacts of heavy rainfall and flood on people and facility.	Medium	Low
<b>Response</b>	-Develop flood hazard map and response protocol.	-Mitigate damage, prevent secondary impacts and expedite recovery.	Low	Low
<b>Roads</b>				
<b>Planning</b>	-Meet international standards.	-Longer service life	Low	High
	-Use large axle load and truck volume for design.	-Less wear, reduce cracking, rut, increase smoothness of pavement.	Low	Low
	-Specify higher reliability.	-Increased design life pavement.	Medium	Medium
<b>Design</b>	-Use stronger and thicker asphalt.	-Better performance during flooding.	Low	Medium
<b>Construction</b>	-Moisture resistant material, improved drainage.	-Reduce submersion depth and duration during flooding.	Low	High

Stage	Resilience Measures	Performance Enhancement	Costs	Savings
	-Composite or rigid overlay.	-Reduce flood risk.	Medium	High
<b>Maintenance</b>	-Develop PMS, including preventive maintenance.	-Identify weak sections, extend design life.	Medium	Medium
	-Restrict traffic loading during floods.	-Reduce impact of flood on pavement.	Low	Medium
<b>Monitoring</b>	-Develop real-time monitoring network and warning system.	-Reduces impacts on people.	Medium	Low
<b>Response</b>	-Develop response protocol.	-Mitigates damage and expedite recovery.	Low	Low
<b>Bridges</b>				
<b>Planning</b>	-Use earthquakes and floods with longer return period in design.	-Less damage, faster return to operation.	Medium	Medium
	-Design the bridge for the large trucks anticipated in the future.	-Extend the useful life of the bridge.	Low	Low
	-Provide 600-900 mm of freeboard.	-Avoid future inundation.	Low	Low
	-Perform geo-technical and hydraulic studies.	-Reduce damage from flood and earthquake during the service life.	Low	Medium
<b>Design</b>	-Follow National or international best practice.	-Design bridge for all loads in the code.	Low	High
	-Use ductile detailing; redundant design;	-Controlled damage in earthquakes, rapid recovery.	Low	Medium
	-Place 25 mm of polyester concrete on the bridge deck.	-Extend service life of a bridge.	Low	Low
<b>Construction</b>	-Inspect the site and monitor activities. Ensure material certification.	-Ensure a high-quality structure is constructed.	Low	High
	-Use circular columns, place riprap near abutments.	-Reduce the impact of local scour.	Low	Medium
	-Extend piles below scour and liquefaction elevations.	-Foundation stability.	Medium	High
<b>Maintenance</b>	-Provide pier protection, when needed,	-Prevent direct hit to bridge supports.	Low	Low
	-Rate the bridge for construction and heavy trucks.	-Prevent overloading of bridge.	Low	Low
	-Inspect the bridge and document findings.	-Preventive maintenance, prevention of major future expenses.	Low	Low
	-Post the maximum truck height that can cross under the bridge.	-Prevent high-load hits.	Low	Low
<b>Monitoring</b>	-Develop real-time monitoring network and warning system.	-Reduce impact allow for rapid response.	Medium	Low
<b>Response</b>	-Develop response protocols.	-Mitigate damage and expedite recovery.	Low	Low
<b>Buildings</b>				
<b>Planning</b>	-Consider hazard with longer return period. Use stronger materials.	-Less damage.	Low	Low
<b>Design</b>	Meet BNBC requirements.	-Longer service life.	Low	High
	-Use anchorage and bracing. Locate equipment above HFL.	-Keep building operational, serve as shelter.	Low	High
<b>Construction</b>	-Soil compaction, deep foundation, soil improvement.	-Reduce settlement and liquefaction.	Med	High
	-Plan review and construction inspection.	-Reduce maintenance cost, safer structure.	Low	High
<b>Maintenance</b>	-Develop and an implement maintenance program.	-Reduce the need for expensive future repairs.	Low	Low

Stage	Resilience Measures	Performance Enhancement	Costs	Savings
<b>Monitoring</b>	-Develop a real-time monitoring network and warning system.	-Reduce impact allow for rapid response.	Med	Low
<b>Response</b>	-Train staff for post-disaster assessment.	-Mitigate damage and expedite recovery.	Low	Low

*(Source: Miyamoto International, 2020)*

### Annexure 3.3 : References

Bangladesh Agricultural Research Council (BARC), 2000. Flood Prone Area Maps of Bangladesh. Retrieved from [www.barc.gov.bd](http://www.barc.gov.bd)

BNBC. (2015). Bangladesh National Building Code (BNBC). Dhaka, Bangladesh: Housing and Building Research Institute (HBRI).

BWDB. (2013). Establishment of Monitoring Network and Mathematical Model Study to Assess Salinity Intrusion in Groundwater in the Coastal Area of Bangladesh due to Climate Change, Package 3: Vol-1-Main Report, Bangladesh Water Development Board (BWDB), Ministry of Water Resources, Dhaka, Bangladesh

Hallegatte, Stephane; Rentschler, Jun; Rozenberg, Julie. 2019. Lifelines : The Resilient Infrastructure Opportunity. Sustainable Infrastructure;. Washington, DC: World Bank. © World Bank. License: CC BY 3.0 IGO. For more information see: <https://openknowledge.worldbank.org/handle/10986/31805>

Hore, R., Arefin, M. and Ansary M. (2019). Development of Zonation Map Based on Soft Clay for Bangladesh. Journal of Engineering Science. Retrieved from <http://www.forsgren.com/disaster-response-infrastructure> <https://www.dhakatribune.com/bangladesh/2017/04/26/goal-becoming-developed-nation-2041>  
<https://www.metoc.navy.mil/jtwc/jtwc.html>

PricewaterhouseCoopers Pvt Ltd. (PwC). (2016). Environmental Impact Assessment Report Mirsarai Economic Zone-II. London: PwC.

Miyamoto International. (2020). “Enhancing Competitive, Green and Resilient Industries in Bangladesh: Integrating resilience within the design and costing of BSMSN Economic Zones 2A and 2B.” (forthcoming report). Commissioned by World Bank Group with technical inputs from Yachiyo Engineering Company. Technical and financial support was provided by the Japan-World Bank Program for Mainstreaming Disaster Risk Management in Developing Countries.

Water Resources Planning Organization (WARPO). (2009). Flood map of Bangladesh. Retrieved from [www.warpo.gov.bd](http://www.warpo.gov.bd)

Yachiyo Engineering Co., Ltd. (2020). “Technical Assessment and recommendations for the plan and design of BSMSN.” Commissioned by World Bank Group. Technical and financial support was provided by the Japan-World Bank Program for Mainstreaming Disaster Risk Management in Developing Countries.



Annexure 4.1: Typical Trumpet Interchange Intersection

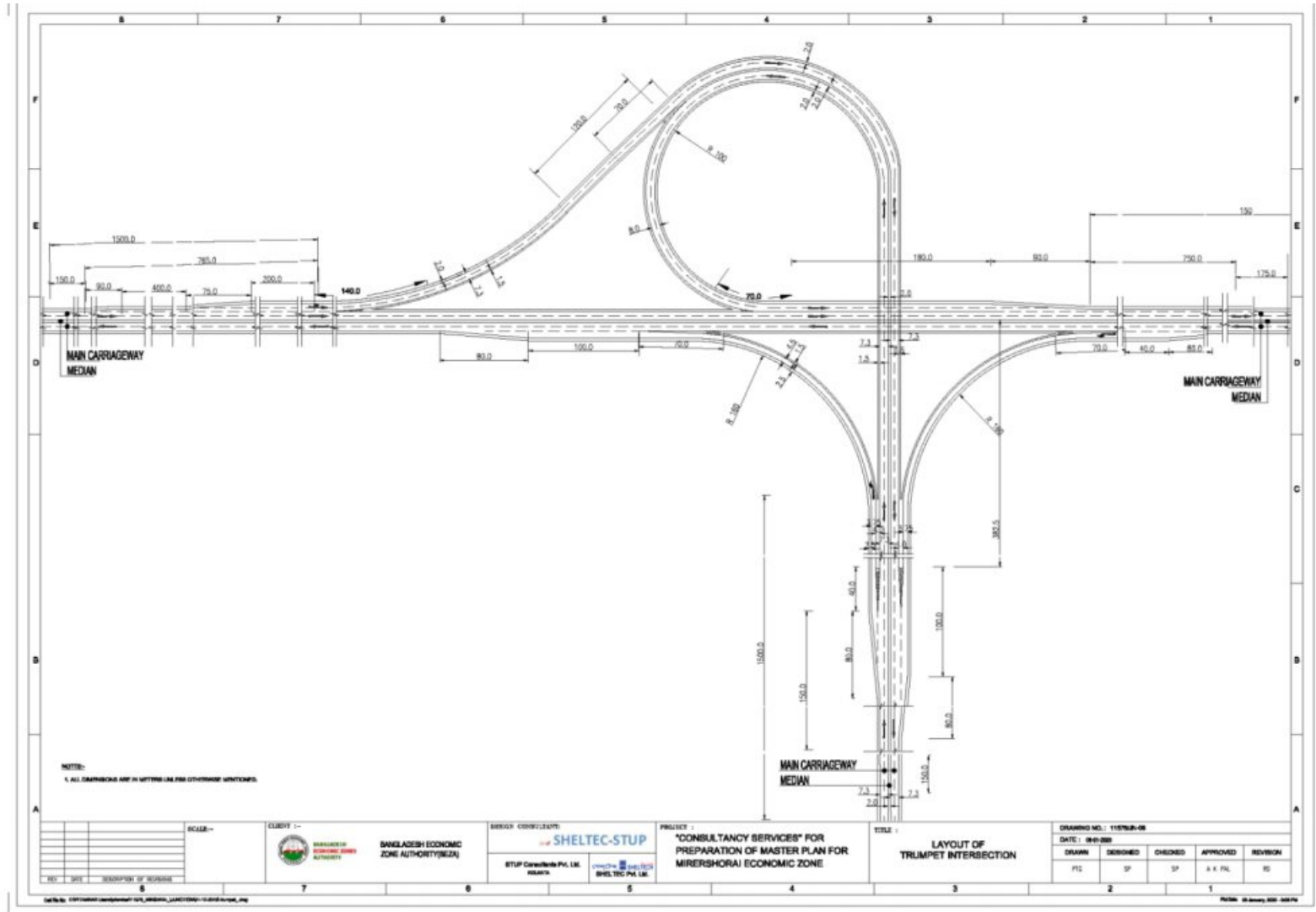

Annexure 4.2: Typical Design for Rotary Intersection

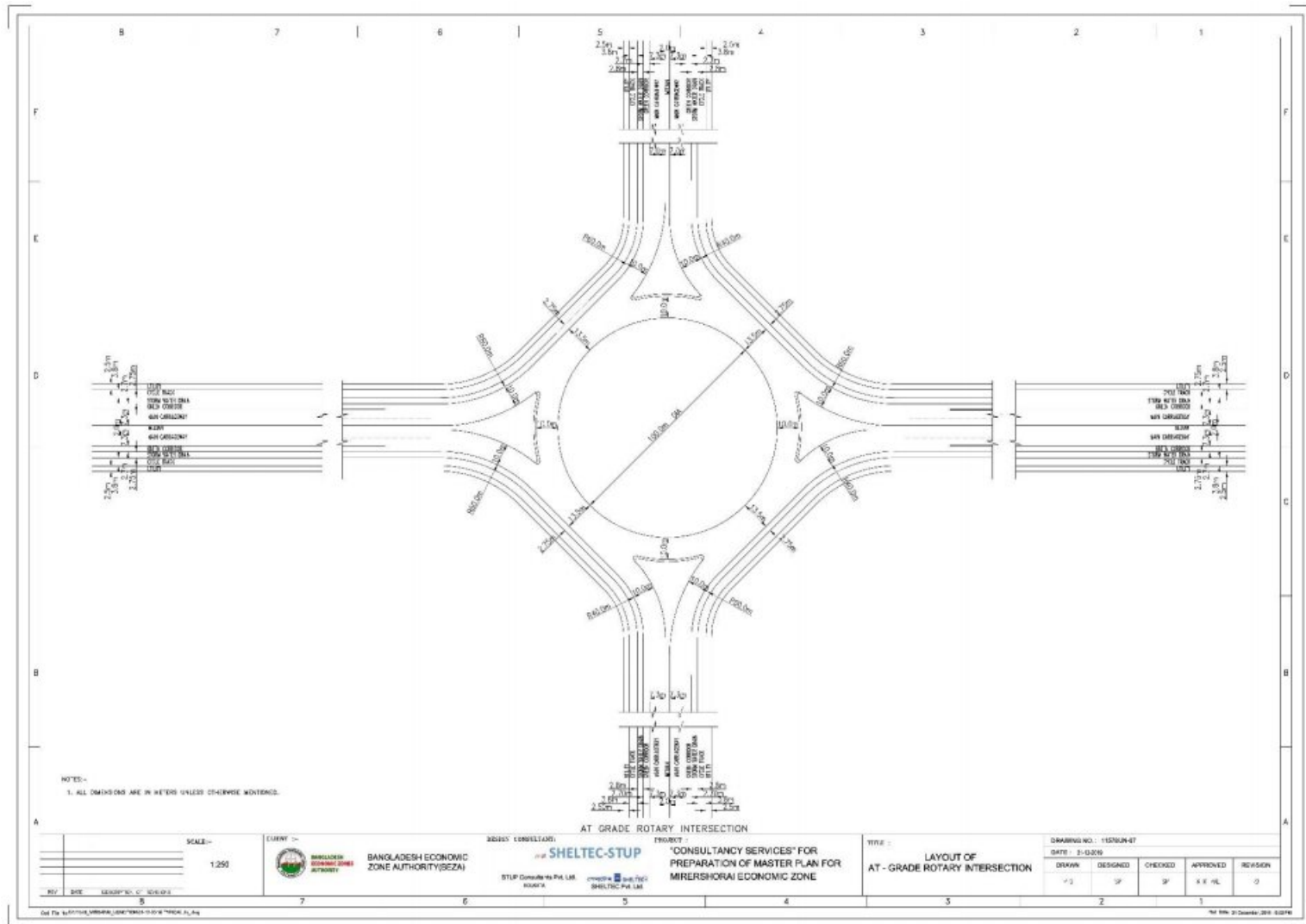

Annexure 4.3: Typical Design for 4 Arm Intersection

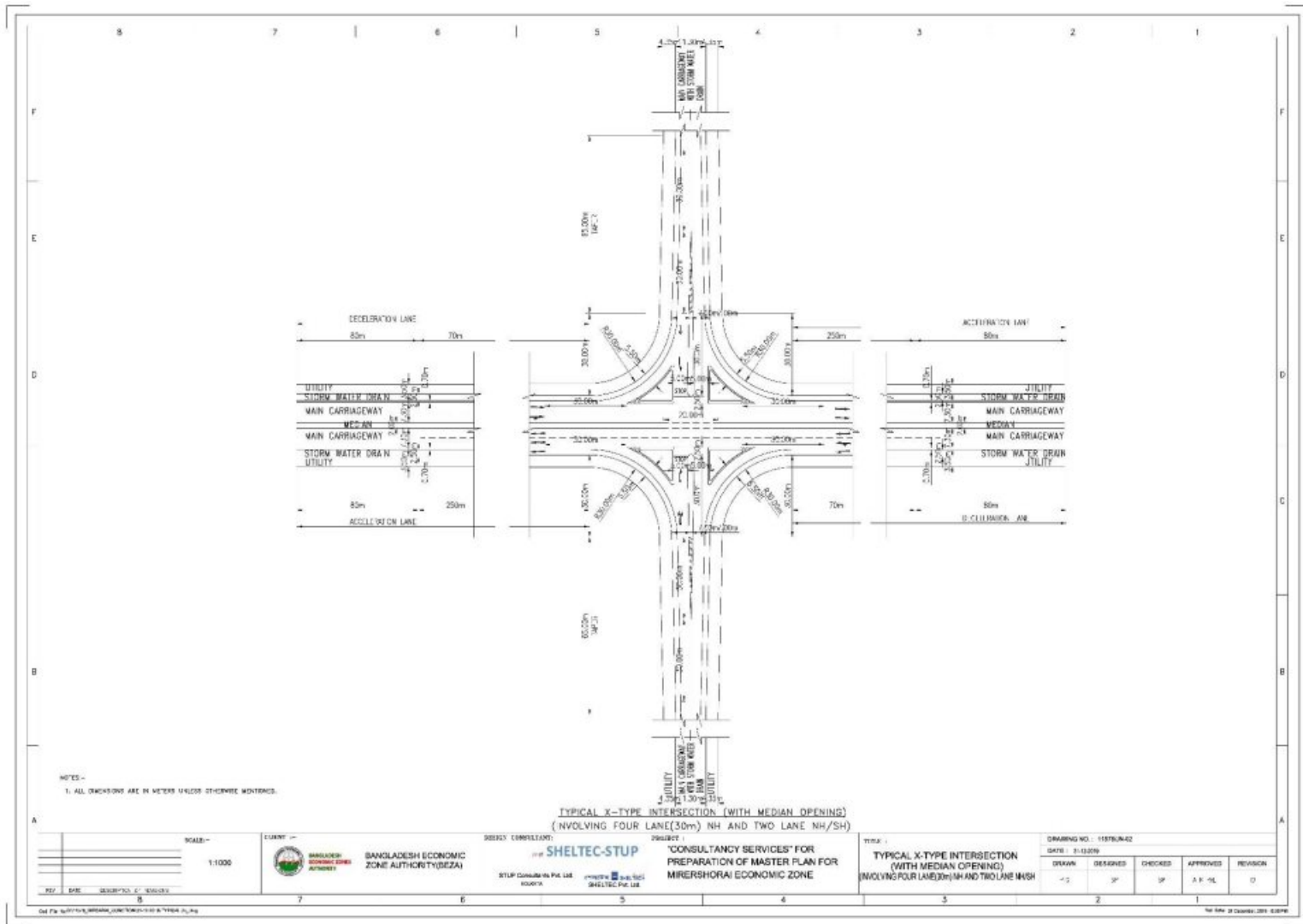

### Annexure 4.4 Typical Design for 3 Arm Intersection

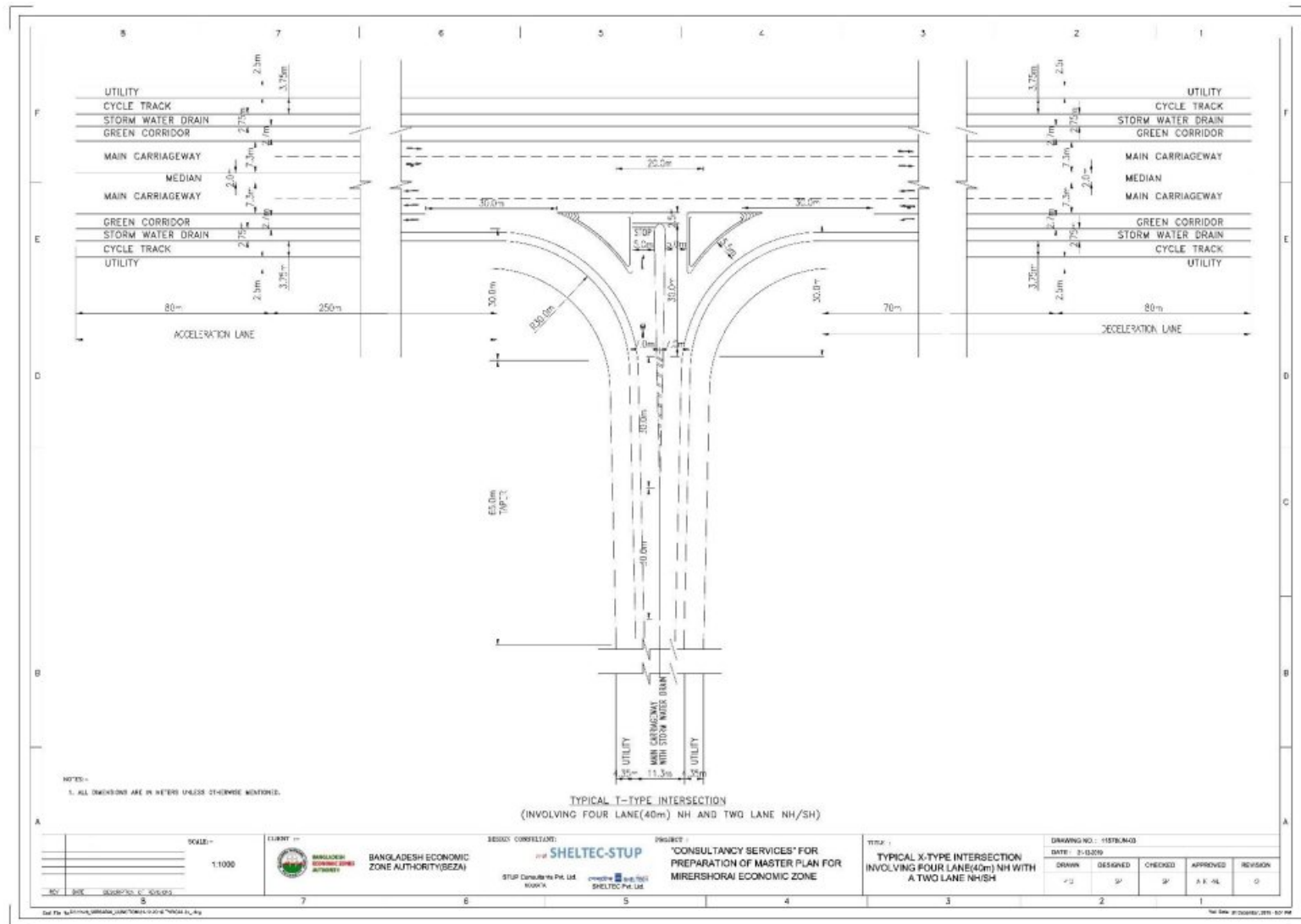

### Annexure 4.5: Table Year Wise Gas Demand (in mmcf/d) up to 2040 in BSMSN area

Industrial Category	Total Gas Demand in mmcf/d	Phase wise Demand		
		First Phase	Second Phase	Third Phase
<b>Chemical Hub</b>				
Chemical	0.15	0.05	0.08	0.15
Chemical, Foam	0.04	0.01	0.02	0.04
Chemical, Paints	3.28	1.19	1.67	3.28
Garments	0.65	0.24	0.33	0.65
<i>Sub Total</i>	<i>4.12</i>	<i>1.5</i>	<i>2.09</i>	<i>4.12</i>
<b>Heavy Industrial</b>				
<i>Sub Total</i>	<i>33.13</i>	<i>12.03</i>	<i>16.8</i>	<i>33.13</i>
<b>Light/ Medium Industrial</b>				
Auto Mobile, Mango	14.42	4.68	14.42	14.42
Bashundhara	79.79	77.25	79.79	79.79
Chemical	0.02	0.01	0.01	0.02
Food and Beverage	0.32	0.12	0.16	0.32
Garments	60.96	22.15	30.91	60.96
Garments Accessories	0.01	0	0	0.01
Light and Medium Industrial Area	20.68	7.51	10.48	20.68
Light Engineering	0.02	0.01	0.01	0.02
LNG Petro Chemical	0	0	0	0
Pharmaceuticals	0.05	0.02	0.03	0.05
Power Plant, B-R Power	40.25	40.25	40.25	40.25
Power Plant, B-R Power Extension	107.75	53.87	53.87	107.75
Power Plant, BSRM Power	52.97	52.97	52.97	52.97
Steel Industry, BSRM	2.06	2.06	2.06	2.06
Steel Industry, PHP	121.7	48.68	121.7	121.7
Steel Product	0.57	0.21	0.29	0.57
Textile	44.05	16	22.34	44.05
Utility	0	0	0	0
<i>Sub Total</i>	<i>545.61</i>	<i>325.77</i>	<i>429.29</i>	<i>545.61</i>
<b>Port/ Logistics/ Light/ Medium Industrial</b>				
<i>Sub Total</i>	<i>1.17</i>	<i>0.42</i>	<i>0.59</i>	<i>1.17</i>
<b>Grand Total (in mmcf/d)</b>	<b>584.03</b>	<b>339.73</b>	<b>448.76</b>	<b>584.03</b>
	<b><i>In Percentage</i></b>	<b>58.17</b>	<b>76.84</b>	<b>100</b>



## Annexure 4.6 : Salient Details of the Water Supply System

Unit	Capacity requirement				Required installations				Pipe size (mm)	Storage reservoir capacity (cum)	Remarks	Land area requirement
	2025	2030	2035	2040	2025	2030	2035	2040				
<b>Installations Required for Off-site Improvement Measures</b>												
<b>Raw Water Drawal and Transmission System</b>												
RWPS 1	52.62 MLD	52.62 MLD	52.62 MLD	52.62 MLD	4 pumps (2W+2S) each of capacity 1100 m <sup>3</sup> /hr	No further augmentation in capacity is required	No further augmentation in capacity is required	No further augmentation in capacity is required	700	-	Flow will be pumped to WTP 1 (source of water reservoir upstream of Feni Regulator - Phase 1)	No land area is required. The structure may be constructed directly over the source
RWPS 2		52.62 MLD	52.62 MLD	52.62 MLD	4 pumps (2W+2S) each of capacity 1100 m <sup>3</sup> /hr	4 pumps (2W+2S) each of capacity 1100 m <sup>3</sup> /hr	No further augmentation in capacity is required	No further augmentation in capacity is required	700	-	Flow will be pumped to WTP 2 (source of water reservoir upstream of Feni Regulator - Phase 2)	No land area is required. The structure may be constructed directly over the source
RWPS 3	-	42.1 MLD	42.1 MLD	42.1 MLD	-	4 pumps (2W+2S) each of capacity 900 m <sup>3</sup> /hr	No further augmentation in capacity is required	No further augmentation in capacity is required	600	-	Flow will be pumped to WTP 3 (source of water reservoir upstream of Musapur Regulator)	No land area is required. The structure may be constructed directly over the source
RWPS 4 (to be installed under separate project)	94.73 MLD	94.73 MLD	94.73 MLD	94.73 MLD	To be installed under separate project	No further augmentation in capacity is expected	No further augmentation in capacity is expected	No further augmentation in capacity is expected	-	-	Flow will be pumped to WTP 4 (to be installed under separate project) (source of water Mohra treatment plant)	To be constructed under separate project
<b>Water Treatment Plant (WTP)</b>												
WTP 1	50 MLD	50 MLD	50 MLD	50 MLD	50 MLD	No further augmentation in capacity is required	No further augmentation in capacity is required	No further augmentation in capacity is required	-	-	Conventional type Treated water will be transmitted by TWPS 1	5 ha (13 acres)

Unit	Capacity requirement				Required installations				Pipe size (mm)	Storage reservoir capacity (cum)	Remarks	Land area requirement
	2025	2030	2035	2040	2025	2030	2035	2040				
WTP 2	-	50 MLD	50 MLD	50 MLD	-	50 MLD	No further augmentation in capacity is required	No further augmentation in capacity is required	-	-	Conventional type Treated water will be transmitted by TWPS 2	5 ha (13 acres)
WTP 3	-	40 MLD	40 MLD	40 MLD	-	40 MLD	No further augmentation in capacity is required	No further augmentation in capacity is required	-	-	Conventional type Treated water will be transmitted by TWPS 3	4 ha (10 acres)
WTP 4 ( <i>to be installed under separate project</i> )	90 MLD	90 MLD	90 MLD	90 MLD	90 MLD	No further augmentation in capacity is required	No further augmentation in capacity is required	No further augmentation in capacity is required	-	-	Considered as existing WTP Treated water will be transmitted by TWPS 4	Implementation under separate project
<b>Treated Water Pumping Station (TWPS) and Transmission System</b>												
TWPS 1	50 MLD	50 MLD	50 MLD	50 MLD	4 pumps (2W+2S) each of capacity 1050 m <sup>3</sup> /hr	No further augmentation in capacity is required	No further augmentation in capacity is required	No further augmentation in capacity is required	700	4200	Will deliver water to different underground storage reservoir - cum - pumping stations (SRPSs)	100m x 75m
TWPS 2	-	50 MLD	50 MLD	50 MLD	-	4 pumps (2W+2S) each of capacity 1050 m <sup>3</sup> /hr	No further augmentation in capacity is required	No further augmentation in capacity is required	700	4200	Will deliver water to different SRPSs	100m x 75m
TWPS 3	-	40 MLD	40 MLD	40 MLD	-	4 pumps (2W+2S) each of capacity 850 m <sup>3</sup> /hr	No further augmentation in capacity is required	No further augmentation in capacity is required	600	3400	Will deliver water to different SRPSs	100m x 75m



Unit	Capacity requirement				Required installations				Pipe size (mm)	Storage reservoir capacity (cum)	Remarks	Land area requirement
	2025	2030	2035	2040	2025	2030	2035	2040				
TWPS 4	90 MLD	90 MLD	90 MLD	90 MLD	5 pumps (3W+2S) each of capacity 1250 m <sup>3</sup> /hr	No further augmentation in capacity is required	No further augmentation in capacity is required	No further augmentation in capacity is required	900	7500	Will deliver water to different SRPSs	120m x 85m
<b>Installations Required for On-site Improvement Measures</b>												
<b>Raw Water Drawal and Transmission System</b>												
RWPS 5	125.56 MLD	125.56 MLD	251.11 MLD	251.11 MLD	6 pumps (4W+2S) each of capacity 1350 m <sup>3</sup> /hr	No further augmentation in capacity is required	Addl. 6 pumps (4W+2S) each of capacity 1350 m <sup>3</sup> /hr	No further augmentation in capacity is required	2 nos. 1000	-	Flow will be pumped to WTP 5 (desalination plant)	No land area is required. The structure may be constructed directly over the source
RWPS 6	-	-	-	426.89 MLD	-	-	-	9 pumps (6W+3S) each of capacity 3000 m <sup>3</sup> /hr	2 nos. 1400	-	Flow will be pumped to WTP 6 (desalination plant)	No land area is required. The structure may be constructed directly over the source
<b>Desalination Plant</b>												
WTP 5	50 MLD	50 MLD	100 MLD	100 MLD	50 MLD	No further augmentation in capacity is required	Augmentation in capacity by 50 MLD	No further augmentation in capacity is required	-	-	Desalination plant Treated water will be transmitted by TWPS 5	20 ha (50 acres)
WTP 6	-	-	-	170 MLD	-	-	-	170 MLD	-	-	Desalination plant Treated water will be transmitted by TWPS 6	30 ha (75 acres)
<b>Treated Water Pumping Station (TWPS) and Transmission System</b>												
TWPS 5	50 MLD	50 MLD	100 MLD	100 MLD	4 pumps (2W+2S) each of capacity 1050 m <sup>3</sup> /hr	No further augmentation in capacity is required	Addl. 3 pumps (2W+1S) each of capacity 1050 m <sup>3</sup> /hr	No further augmentation in capacity is required	900	8400	Will deliver water to different SRPSs	125m x 90m
TWPS 6	-	-	-	170 MLD	-	-	-	8 pumps (5W+3S) each of capacity 1450 m <sup>3</sup> /hr	1200	14200	Will deliver water to different SRPSs	150m x 100m

Unit	Capacity requirement				Required installations				Pipe size (mm)	Storage reservoir capacity (cum)	Remarks	Land area requirement
	2025	2030	2035	2040	2025	2030	2035	2040				
<b>Underground Storage Reservoir (UGSR) with Pumping Arrangement for Distribution System</b>												
SRPS 1	-	2.32 MLD	3.47 MLD	4.63 MLD	-	3 pumps (2W+1S) each of capacity 50 m <sup>3</sup> /hr	Addl. 2 pumps (1W+1S) of capacity 50 m <sup>3</sup> /hr	Addl. 1 pump (W) of capacity 50 m <sup>3</sup> /hr	-	400	Size ranging from 250 mm to 100 mm for distribution main network	60m x 50m
SRPS 2	1.80 MLD	5.41 MLD	9.62 MLD	12.02 MLD	2 pumps (1W+1S) each of capacity 75 m <sup>3</sup> /hr	Addl. 3 pumps (2W+1S) each of capacity 75 m <sup>3</sup> /hr	Addl. 3 pump (2W+1S) of capacity 100 m <sup>3</sup> /hr	Addl. 1 pump (W) of capacity 75 m <sup>3</sup> /hr	-	1000	Size ranging from 350 mm to 100 mm for distribution main network	70m x 50m
SRPS 3	2.32 MLD	6.95 MLD	12.35 MLD	15.44 MLD	3 pumps (2W+1S) each of capacity 50 m <sup>3</sup> /hr	Addl. 3 pumps (2W+1S) each of capacity 100 m <sup>3</sup> /hr	Addl. 3 pumps (2W+1S) each of capacity 125 m <sup>3</sup> /hr	Addl. 2 pumps (1W+1S) each of capacity 100 m <sup>3</sup> /hr	-	1300	Size ranging from 400 mm to 100 mm for distribution main network	70m x 60m
SRPS 4	-	3.94 MLD	6.90 MLD	9.86 MLD	-	3 pumps (2W+1S) each of capacity 85 m <sup>3</sup> /hr	Addl. 2 pumps (1W+1S) each of capacity 120 m <sup>3</sup> /hr	Addl. 2 pumps (1W+1S) each of capacity 120 m <sup>3</sup> /hr	-	850	Size ranging from 350 mm to 100 mm for distribution main network	70m x 50m
SRPS 5	1.88 MLD	7.52 MLD	15.03 MLD	18.79 MLD	3 pumps (2W+1S) each of capacity 50 m <sup>3</sup> /hr	Addl. 3 pumps (2W+1S) each of capacity 100 m <sup>3</sup> /hr	Addl. 3 pumps (2W+1S) each of capacity 150 m <sup>3</sup> /hr	Addl. 2 pumps (1W+1S) each of capacity 150 m <sup>3</sup> /hr	-	1600	Size ranging from 450 mm to 100 mm for distribution main network	75m x 60m
SRPS 6	-	2.13 MLD	3.41 MLD	4.26 MLD	-	3 pumps (2W+1S) each of capacity 50 m <sup>3</sup> /hr	Addl. 2 pumps (1W+1S) each of capacity 50 m <sup>3</sup> /hr	Addl. 1 pump (W) of capacity 50 m <sup>3</sup> /hr	-	350	Size ranging from 200 mm to 100 mm for distribution main network	60m x 50m
SRPS 7	-	2.93 MLD	4.69 MLD	5.86 MLD	-	3 pumps (2W+1S) each of capacity 75 m <sup>3</sup> /hr	Addl. 2 pumps (1W+1S) each of capacity 50 m <sup>3</sup> /hr	Addl. 2 pumps (1W+1S) each of capacity 50 m <sup>3</sup> /hr	-	500	Size ranging from 250 mm to 100 mm for distribution main network	60m x 50m
SRPS 8	-	7.59 MLD	12.14 MLD	15.18 MLD	-	3 pumps (2W+1S) each of capacity 175 m <sup>3</sup> /hr	Addl. 2 pumps (1W+1S) each of capacity 175 m <sup>3</sup> /hr	Addl. 2 pumps (1W+1S) each of capacity 125 m <sup>3</sup> /hr	-	1300	Size ranging from 400 mm to 100 mm for distribution main network	70m x 60m
SRPS 9	6.55 MLD	19.65 MLD	26.20 MLD	32.75 MLD	3 pumps (2W+1S) each of capacity 150 m <sup>3</sup> /hr	Addl. 3 pumps (2W+1S) each of capacity 250 m <sup>3</sup> /hr	Addl. 2 pumps (1W+1S) each of capacity 300 m <sup>3</sup> /hr	Addl. 1 pump (W) of capacity 300 m <sup>3</sup> /hr	-	2800	Size ranging from 600 mm to 100 mm for distribution main network	100m x 70m

Unit	Capacity requirement				Required installations				Pipe size (mm)	Storage reservoir capacity (cum)	Remarks	Land area requirement
	2025	2030	2035	2040	2025	2030	2035	2040				
SRPS 10	1.52 MLD	6.83 MLD	12.14 MLD	15.18 MLD	2 pumps (1W+1S) each of capacity 60 m <sup>3</sup> /hr	Addl. 3 pumps (2W+1S) each of capacity 120 m <sup>3</sup> /hr	Addl. 3 pumps (2W+1S) each of capacity 100 m <sup>3</sup> /hr	Addl. 2 pumps (1W+1S) each of capacity 150 m <sup>3</sup> /hr	-	1300	Size ranging from 400 mm to 100 mm for distribution main network	70m x 60m
SRPS 11	7.62 MLD	22.87 MLD	30.49 MLD	38.11 MLD	3 pumps (2W+1S) each of capacity 175 m <sup>3</sup> /hr	Addl. 3 pumps (2W+1S) each of capacity 300 m <sup>3</sup> /hr	Addl. 2 pumps (1W+1S) each of capacity 350 m <sup>3</sup> /hr	Addl. 2 pumps (1W+1S) each of capacity 300 m <sup>3</sup> /hr	-	3200	Size ranging from 600 mm to 100 mm for distribution main network	100m x 75m
SRPS 12	4.92 MLD	14.77 MLD	19.69 MLD	24.61 MLD	3 pumps (2W+1S) each of capacity 100 m <sup>3</sup> /hr	Addl. 3 pumps (2W+1S) each of capacity 225 m <sup>3</sup> /hr	Addl. 2 pumps (1W+1S) each of capacity 200 m <sup>3</sup> /hr	Addl. 1 pump (W) of capacity 200 m <sup>3</sup> /hr	-	2100	Size ranging from 500 mm to 100 mm for distribution main network	90m x 70m
SRPS 13	5.64 MLD	16.93 MLD	22.57 MLD	28.21 MLD	3 pumps (2W+1S) each of capacity 125 m <sup>3</sup> /hr	Addl. 3 pumps (2W+1S) each of capacity 225 m <sup>3</sup> /hr	Addl. 2 pumps (1W+1S) each of capacity 250 m <sup>3</sup> /hr	Addl. 1 pump (W) of capacity 250 m <sup>3</sup> /hr	-	2400	Size ranging from 600 mm to 100 mm for distribution main network	90m x 70m
SRPS 14	6.35 MLD	19.04 MLD	25.38 MLD	31.73 MLD	3 pumps (2W+1S) each of capacity 150 m <sup>3</sup> /hr	Addl. 3 pumps (2W+1S) each of capacity 250 m <sup>3</sup> /hr	Addl. 2 pumps (1W+1S) each of capacity 250 m <sup>3</sup> /hr	Addl. 2 pumps (1W+1S) each of capacity 275 m <sup>3</sup> /hr	-	2700	Size ranging from 600 mm to 100 mm for distribution main network	100m x 70m
SRPS 15	4.99 MLD	19.97 MLD	26.63 MLD	33.29 MLD	3 pumps (2W+1S) each of capacity 125 m <sup>3</sup> /hr	Addl. 3 pumps (2W+1S) each of capacity 300 m <sup>3</sup> /hr	Addl. 2 pumps (1W+1S) each of capacity 300 m <sup>3</sup> /hr	Addl. 2 pumps (1W+1S) each of capacity 250 m <sup>3</sup> /hr	-	2800	Size ranging from 600 mm to 100 mm for distribution main network	100m x 70m
SRPS 16	-	15.61 MLD	24.98 MLD	31.22 MLD	-	3 pumps (2W+1S) each of capacity 325 m <sup>3</sup> /hr	Addl. 2 pumps (1W+1S) each of capacity 400 m <sup>3</sup> /hr	Addl. 2 pumps (1W+1S) each of capacity 250 m <sup>3</sup> /hr	-	2600	Size ranging from 600 mm to 100 mm for distribution main network	100m x 70m
SRPS 17	-	25.19 MLD	35.59 MLD	50.32 MLD	-	5 pumps (3W+2S) each of capacity 300 m <sup>3</sup> /hr	Addl. 3 pumps (2W+1S) each of capacity 250 m <sup>3</sup> /hr	Addl. 2 pumps (1W+1S) each of capacity 300 m <sup>3</sup> /hr	-	3400	Size ranging from 700 mm to 100 mm for distribution main network	100m x 75m
SRPS 18	-	8.53 MLD	13.65 MLD	17.06 MLD	-	3 pumps (2W+1S) each	Addl. 2 pumps (1W+1S) each	Addl. 2 pumps (1W+1S) each	-	1500	Size ranging from 400 mm to 100 mm for distribution main network	70m x 60m

Unit	Capacity requirement				Required installations				Pipe size (mm)	Storage reservoir capacity (cum)	Remarks	Land area requirement
	2025	2030	2035	2040	2025	2030	2035	2040				
						of capacity 200 m <sup>3</sup> /hr	of capacity 200 m <sup>3</sup> /hr	of capacity 150 m <sup>3</sup> /hr				
SRPS 19	-	15.03 MLD	34.36 MLD	42.95 MLD	-	3 pumps (2W+1S) each of capacity 325 m <sup>3</sup> /hr	Addl. 3 pumps (2W+1S) each of capacity 400 m <sup>3</sup> /hr	Addl. 2 pumps (1W+1S) each of capacity 350 m <sup>3</sup> /hr	-	3600	Size ranging from 700 mm to 100 mm for distribution main network	100m x 75m
SRPS 20	-	8.37 MLD	16.74 MLD	20.92 MLD	-	3 pumps (2W+1S) each of capacity 175 m <sup>3</sup> /hr	Addl. 2 pumps (1W+1S) each of capacity 350 m <sup>3</sup> /hr	Addl. 2 pumps (1W+1S) each of capacity 200 m <sup>3</sup> /hr	-	1800	Size ranging from 500 mm to 100 mm for distribution main network	75m x 60m
SRPS 21	-	14.94 MLD	34.86 MLD	49.80 MLD	-	3 pumps (2W+1S) each of capacity 325 m <sup>3</sup> /hr	Addl. 3 pumps (2W+1S) each of capacity 400 m <sup>3</sup> /hr	Addl. 3 pumps (2W+1S) each of capacity 325 m <sup>3</sup> /hr	-	4200	Size ranging from 700 mm to 100 mm for distribution main network	100m x 75m
SRPS 22	-	7.32 MLD	25.61 MLD	36.58 MLD	-	3 pumps (2W+1S) each of capacity 150 m <sup>3</sup> /hr	Addl. 3 pumps (2W+1S) each of capacity 400 m <sup>3</sup> /hr	Addl. 3 pumps (2W+1S) each of capacity 225 m <sup>3</sup> /hr	-	3100	Size ranging from 600 mm to 100 mm for distribution main network	100m x 75m
SRPS 23	-	-	12.65 MLD	25.29 MLD	-	-	3 pumps (2W+1S) each of capacity 275 m <sup>3</sup> /hr	Addl. 3 pumps (2W+1S) each of capacity 250 m <sup>3</sup> /hr	-	2100	Size ranging from 500 mm to 100 mm for distribution main network	90m x 70m
SRPS 24	-	-	9.00 MLD	22.50 MLD	-	-	3 pumps (2W+1S) each of capacity 200 m <sup>3</sup> /hr	Addl. 3 pumps (2W+1S) each of capacity 275 m <sup>3</sup> /hr	-	1900	Size ranging from 500 mm to 100 mm for distribution main network	90m x 70m
SRPS 25	-	-	2.56 MLD	12.81 MLD	-	-	2 pumps (1W+1S) each of capacity 100 m <sup>3</sup> /hr	Addl. 3 pumps (2W+1S) each of capacity 225 m <sup>3</sup> /hr	-	1100	Size ranging from 400 mm to 100 mm for distribution main network	70m x 60m

## Annexure 4.7 : Storm Runoff Contribution to Different Drainage Catchment Areas

Catchment designation	Contributing area within BSMSN	Length of channel within BSMSN (km)	Catchment area (ha)			Storm runoff generated (m <sup>3</sup> /hr)			No. of major drainage outlets from BSMSN	Average flow through each major drainage outlet (m <sup>3</sup> /hr)	Minimum size requirement for the drainage channel			Approx. size of individual drainage outlets		Pumping station details
			Within BSMSN	Outside BSMSN	Total	Within BSMSN	Outside BSMSN	Total			Bottom width (m)	Top width (m)	Liquid depth (m)	Width (m)	Liquid depth (m)	
EDC 1	Portion of Precinct I	1.2	270	1350	1620	55800	185800	241600	5	6700	10.0	22.0	4.0	2.5	1.7	Capacity: 100000 m <sup>3</sup> /hr Sump capacity required: 8500 m <sup>3</sup> Pumps to be installed: 13 nos. (10W+3S) each 10000 m <sup>3</sup> /hr Land required: 115m x 90n
EDC 2	Portion of Precinct I	1.2	275	1375	1650	56800	189200	246000	6	5700	10.0	22.0	4.0	2.5	1.5	Capacity: 100000 m <sup>3</sup> /hr Sump capacity required: 8500 m <sup>3</sup> Pumps to be installed: 13 nos. (10W+3S) each 10000 m <sup>3</sup> /hr Land required: 115m x 90n
EDC 3	Portion of Precinct I	1.2	510	1275	1785	105300	175500	280800	6	10600	10.0	23.5	4.5	3.0	2.0	Capacity: 115000 m <sup>3</sup> /hr Sump capacity required: 9600 m <sup>3</sup> Pumps to be installed: 13 nos. (10W+3S) each 11500 m <sup>3</sup> /hr Land required: 120m x 90n
EDC 4	Portion of Precinct I	1.6	560	2800	3360	115600	385300	500900	6	11600	15.0	30.0	5.0	3.1	2.0	Capacity: 200000 m <sup>3</sup> /hr Sump capacity required: 17000 m <sup>3</sup> Pumps to be installed: 15 nos. (12W+3S) each 16700 m <sup>3</sup> /hr Land required: 150m x 100n
EDC 5 (Domkhali Khal)	Portion of Precinct H	1.8	355	1775	2130	73300	244300	317600	2	22000	11.0	24.5	4.5	3.5	3.0	Capacity: 130000 m <sup>3</sup> /hr Sump capacity required: 11000 m <sup>3</sup> Pumps to be installed: 13 nos. (10W+3S) each 13000 m <sup>3</sup> /hr Land required: 120m x 90n
EDC 6 (Saherkhali Khal)	Precinct G and Portion of Precinct H	2.4	1015	3045	4060	209500	419000	628500	4	31500	20.0	35.0	5.0	4.5	3.0	Capacity: 250000 m <sup>3</sup> /hr Sump capacity required: 21000 m <sup>3</sup> Pumps to be installed: 20 nos. (16W+4S) each 15700 m <sup>3</sup> /hr Land required: 150m x 110n

Catchment designation	Contributing area within BSMSN	Length of channel within BSMSN (km)	Catchment area (ha)			Storm runoff generated (m <sup>3</sup> /hr)			No. of major drainage outlets from BSMSN	Average flow through each major drainage outlet (m <sup>3</sup> /hr)	Minimum size requirement for the drainage channel			Approx. size of individual drainage outlets		Pumping station details
			Within BSMSN	Outside BSMSN	Total	Within BSMSN	Outside BSMSN	Total			Bottom width (m)	Top width (m)	Liquid depth (m)	Width (m)	Liquid depth (m)	
EDC 7	Portion of Precinct F	3.5	205	410	615	42400	56500	98900	5	7310	8.0	17.0	3.0	2.0	1.8	Capacity: 40000 m <sup>3</sup> /hr Sump capacity required: 3500 m <sup>3</sup> Pumps to be installed: 7 nos. (5W+2S) each 8000 m <sup>3</sup> /hr Land required: 100m x 80n
EDC 8 (Haonia Khal)	Portion of Precinct F	4.8	770	1925	2695	159000	264900	423900	8	12000	13.0	28.0	5.0	3.0	2.2	Capacity: 170000 m <sup>3</sup> /hr Sump capacity required: 14000 m <sup>3</sup> Pumps to be installed: 15 nos. (12W+3S) each 14200 m <sup>3</sup> /hr Land required: 130m x 90n
EDC 9 (Bamons undor Khal)	Portion of Precinct F	4.3	1185	9480	10665	244600	1304500	1549100	12	12300	29.0	50.0	7.0	3.0	2.2	Capacity: 620000 m <sup>3</sup> /hr Sump capacity required: 52000 m <sup>3</sup> Pumps to be installed: 25 nos. (20W+5S) each 31000 m <sup>3</sup> /hr Land required: 200m x 150n
EDC 10 (Dabarkhali Khal)	Portion of Precinct F	4.2	685	825	1510	141400	113600	255000	8	7310	12.0	24.0	4.0	3.0	2.0	Capacity: 100000 m <sup>3</sup> /hr Sump capacity required: 8500 m <sup>3</sup> Pumps to be installed: 13 nos. (10W+3S) each 10000 m <sup>3</sup> /hr Land required: 115m x 90n
EDC 11 (Ichakhali Khal)	Precincts B, C, D and portion of Precincts E and F	12.8	3470	6940	13880	716300	955000	1671300	12	35900	30.0	51.0	7.0	5.0	3.0	Capacity: 670000 m <sup>3</sup> /hr Sump capacity required: 56000 m <sup>3</sup> Pumps to be installed: 25 nos. (20W+5S) each 33500 m <sup>3</sup> /hr Land required: 200m x 150n
EDC 12	Portion of Precinct A	4.8	1270	3810	11430	262200	524300	786500	6	26300	18.0	36.0	6.0	4.0	3.0	Capacity: 315000 m <sup>3</sup> /hr Sump capacity required: 26250 m <sup>3</sup> Pumps to be installed: 20 nos. (16W+4S) each 19700 m <sup>3</sup> /hr Land required: 160m x 120n
EDC 13	Portion of Precinct A	3.6	620	1240	3720	128000	170700	298700	2	38400	10.0	23.5	4.5	5.0	3.0	Capacity: 120000 m <sup>3</sup> /hr, Sump capacity required: 10000 m <sup>3</sup> , Pumps to be installed: 13 nos. (10W+3S) each 12000 m <sup>3</sup> /hr Land required: 120m x 90n

Annexure

**Annexure 4.8 : Salient Details of Liquid Waste Collection System**

Proposed installation	Area coverage	Individual sewage generation (MLD)				Cumulative sewage generation (MLD)				Proposed installations				Pumping main size proposed (mm)	Remarks	Land area requirement
		2025	2030	2035	2040	2025	2030	2035	2040	2025	2030	2035	2040			
<b>Within the command area of sewage treatment plant 1 (STP 1)</b>																
SPS 1	Portion of Precinct A	0.795	1.143	1.659	2.426	0.795	1.143	1.659	2.426	3 pumps (2W+1S) each of capacity 65 m <sup>3</sup> /hr + 2 pumps (1W+1S) each of capacity 25 m <sup>3</sup> /hr	Addl. 2 pumps (1W+1S) each of capacity 65 m <sup>3</sup> /hr	Addl. 2 pumps (1W+1S) each of capacity 85 m <sup>3</sup> /hr	Addl. 2 pumps (1W+1S) each of capacity 120 m <sup>3</sup> /hr	300		40m x 25m
SPS 2	Portion of Precinct A	1.311	1.886	2.737	4.002	1.311	1.886	2.737	4.002	3 pumps (2W+1S) each of capacity 130 m <sup>3</sup> /hr + 2 pumps (1W+1S) each of capacity 45 m <sup>3</sup> /hr	Addl. 2 pumps (1W+1S) each of capacity 130 m <sup>3</sup> /hr	Addl. 2 pumps (1W+1S) each of capacity 160 m <sup>3</sup> /hr	Addl. 2 pumps (1W+1S) each of capacity 250 m <sup>3</sup> /hr	400		50m x 30m
SPS 3	Portion of Precinct A	1.172	1.687	2.448	3.579	2.745	3.950	5.732	8.381	3 pumps (2W+1S) each of capacity 195 m <sup>3</sup> /hr + 2 pumps (1W+1S) each of capacity 80 m <sup>3</sup> /hr	Addl. 2 pumps (1W+1S) each of capacity 160 m <sup>3</sup> /hr	Addl. 2 pumps (1W+1S) each of capacity 250 m <sup>3</sup> /hr	Addl. 2 pumps (1W+1S) each of capacity 375 m <sup>3</sup> /hr	500	In addition will cater pumped discharge from SPS 2	60m x 40m
Terminal PS within STP 1 area	Portion of Precinct A	10.140	14.587	21.169	30.953	13.680	19.680	28.560	41.760	6 pumps (4W+2S) each of capacity 375 m <sup>3</sup> /hr	Addl. 3 pumps (2W+1S) each of capacity 350 m <sup>3</sup> /hr	Addl. 3 pumps (2W+1S) each of capacity 500 m <sup>3</sup> /hr	Addl. 3 pumps (2W+1S) each of capacity 720 m <sup>3</sup> /hr	1000	In addition will cater pumped discharge from SPS 1 and 3	80m x 60m

Proposed installation	Area coverage	Individual sewage generation (MLD)				Cumulative sewage generation (MLD)				Proposed installations				Pumping main size proposed (mm)	Remarks	Land area requirement
		2025	2030	2035	2040	2025	2030	2035	2040	2025	2030	2035	2040			
<b>Within the command area of sewage treatment plant 2 (STP 2)</b>																
SPS 4	Portion of Precincts C and D	5.810	8.360	12.140	17.750	5.810	8.360	12.140	17.750	3 pumps (2W+1S) each of capacity 400 m <sup>3</sup> /hr + 3 pumps (2W+1S) each of capacity 160 m <sup>3</sup> /hr	Addl. 2 pumps (1W+1S) each of capacity 400 m <sup>3</sup> /hr	Addl. 2 pumps (1W+1S) each of capacity 450 m <sup>3</sup> /hr	Addl. 3 pumps (2W+1S) each of capacity 400 m <sup>3</sup> /hr	700		70m x 50m
SPS 5	Precinct E and Portion of Precinct D	6.610	9.510	13.800	20.180	6.610	9.510	13.800	20.180	3 pumps (2W+1S) each of capacity 450 m <sup>3</sup> /hr + 3 pumps (2W+1S) each of capacity 185 m <sup>3</sup> /hr	Addl. 2 pumps (1W+1S) each of capacity 450 m <sup>3</sup> /hr	Addl. 2 pumps (1W+1S) each of capacity 600 m <sup>3</sup> /hr	Addl. 3 pumps (2W+1S) each of capacity 425 m <sup>3</sup> /hr	750		70m x 50m
Terminal PS within STP 2 area	Precinct B and Portion of Precincts C and D	12.650	18.200	26.420	38.630	25.070	36.070	52.360	76.560	3 pumps (2W+1S) each of capacity 1400 m <sup>3</sup> /hr + 3 pumps (2W+1S) each of capacity 350 m <sup>3</sup> /hr	Addl. 2 pumps (1W+1S) each of capacity 1200 m <sup>3</sup> /hr	Addl. 3 pumps (2W+1S) each of capacity 900 m <sup>3</sup> /hr	Addl. 3 pumps (2W+1S) each of capacity 1350 m <sup>3</sup> /hr	1400	In addition will cater pumped discharge from SPS 4 and SPS 5	100m x 75m
<b>Within the command area of common effluent treatment plant 1 (CETP 1)</b>																
CEPS 1	Portion of Precinct F	13.657	19.040	26.811	37.672	13.657	19.040	26.811	37.672	5 pumps (3W+2S) each of capacity 500 m <sup>3</sup> /hr + 3 pumps (2W+1S) each of capacity 600 m <sup>3</sup> /hr	Addl. 2 pumps (1W+1S) each of capacity 600 m <sup>3</sup> /hr	Addl. 3 pumps (2W+1S) each of capacity 450 m <sup>3</sup> /hr	Addl. 3 pumps (2W+1S) each of capacity 600 m <sup>3</sup> /hr	900		80m x 60m



Proposed installation	Area coverage	Individual sewage generation (MLD)				Cumulative sewage generation (MLD)				Proposed installations				Pumping main size proposed (mm)	Remarks	Land area requirement
		2025	2030	2035	2040	2025	2030	2035	2040	2025	2030	2035	2040			
CEPS 2	Portion of Precinct F									capacity 190 m <sup>3</sup> /hr						
		15.576	21.715	30.578	42.965	15.576	21.715	30.578	42.965	5 pumps (3W+2S) each of capacity 600 m <sup>3</sup> /hr + 3 pumps (2W+1S) each of capacity 225 m <sup>3</sup> /hr	Addl. 2 pumps (1W+1S) each of capacity 600 m <sup>3</sup> /hr	Addl. 3 pumps (2W+1S) each of capacity 500 m <sup>3</sup> /hr	Addl. 3 pumps (2W+1S) each of capacity 1100 m <sup>3</sup> /hr	1000		80m x 60m
		8.522	11.882	16.731	23.509	24.098	33.597	47.309	66.474	8 pumps (5W+3S) each of capacity 550 m <sup>3</sup> /hr + 3 pumps (2W+1S) each of capacity 350 m <sup>3</sup> /hr	Addl. 3 pumps (2W+1S) each of capacity 500 m <sup>3</sup> /hr	Addl. 3 pumps (2W+1S) each of capacity 750 m <sup>3</sup> /hr	Addl. 3 pumps (2W+1S) each of capacity 1100 m <sup>3</sup> /hr	1200	In addition will cater pumped discharge from CEPS 2	90m x 70m
		6.729	9.382	13.210	18.562	15.265	21.282	29.967	42.107	5 pumps (3W+2S) each of capacity 575 m <sup>3</sup> /hr + 3 pumps (2W+1S) each of capacity 225 m <sup>3</sup> /hr	Addl. 2 pumps (1W+1S) each of capacity 700 m <sup>3</sup> /hr	Addl. 3 pumps (2W+1S) each of capacity 500 m <sup>3</sup> /hr	Addl. 3 pumps (2W+1S) each of capacity 625 m <sup>3</sup> /hr	1800	In addition will cater pumped discharge from CEPS 5	80m x 60m
		8.536	11.900	16.757	23.545	8.536	11.900	16.757	23.545	3 pumps (2W+1S) each of capacity 475 m <sup>3</sup> /hr + 2 pumps (1W+1S) each of capacity	Addl. 2 pumps (1W+1S) each of capacity 400 m <sup>3</sup> /hr	Addl. 2 pumps (1W+1S) each of capacity 500 m <sup>3</sup> /hr	Addl. 2 pumps (1W+1S) each of capacity 775 m <sup>3</sup> /hr	700		75m x 50m

Proposed installation	Area coverage	Individual sewage generation (MLD)				Cumulative sewage generation (MLD)				Proposed installations				Pumping main size proposed (mm)	Remarks	Land area requirement
		2025	2030	2035	2040	2025	2030	2035	2040	2025	2030	2035	2040			
Terminal PS within CETP 3 area	Portion of Precinct F	13.148	18.330	25.810	36.267	52.511	73.209	103.086	144.848	250 m <sup>3</sup> /hr				1800	In addition will cater pumped discharge from CEPS 3 and CEPS 4	150m x 80m
										8 pumps (5W+3S) each of capacity 1150 m <sup>3</sup> /hr + 3 pumps (2W+1S) each of capacity 750 m <sup>3</sup> /hr	Addl. 3 pumps (2W+1S) each of capacity 1200 m <sup>3</sup> /hr	Addl. 5 pumps (3W+2S) each of capacity 1100 m <sup>3</sup> /hr	Addl. 6 pumps (4W+2S) each of capacity 1150 m <sup>3</sup> /hr			
<b>Within the command area of common effluent treatment plant 2 (CETP 2)</b>																
CEPS 6	Portion of Precinct I	15.440	20.591	28.700	40.403	15.440	20.591	28.700	40.403	3 pumps (2W+1S) each of capacity 1150 m <sup>3</sup> /hr + 2 pumps (1W+1S) each of capacity 575 m <sup>3</sup> /hr	Addl. 2 pumps (1W+1S) each of capacity 900 m <sup>3</sup> /hr	Addl. 2 pumps (1W+1S) each of capacity 1300 m <sup>3</sup> /hr	Addl. 3 pumps (2W+1S) each of capacity 900 m <sup>3</sup> /hr	1100		80m x 60m
										6 pumps (4W+2S) each of capacity 1500 m <sup>3</sup> /hr + 3 pumps (2W+1S) each of capacity 775 m <sup>3</sup> /hr	Addl. 3 pumps (2W+1S) each of capacity 1250 m <sup>3</sup> /hr	Addl. 3 pumps (2W+1S) each of capacity 1750 m <sup>3</sup> /hr	Addl. 6 new pumps (4W+2S) each of capacity 1200 m <sup>3</sup> /hr			
CEPS 7	Portion of Precinct I	23.445	32.678	46.003	64.620	54.998	76.657	107.916	151.589	6 pumps (4W+2S) each of capacity 1500 m <sup>3</sup> /hr + 3 pumps (2W+1S) each of capacity 775 m <sup>3</sup> /hr	Addl. 3 pumps (2W+1S) each of capacity 1250 m <sup>3</sup> /hr	Addl. 3 pumps (2W+1S) each of capacity 1750 m <sup>3</sup> /hr	Addl. 6 new pumps (4W+2S) each of capacity 1200 m <sup>3</sup> /hr	1800	In addition will cater pumped discharge from CEPS 8	150m x 80m

Proposed installation	Area coverage	Individual sewage generation (MLD)				Cumulative sewage generation (MLD)				Proposed installations				Pumping main size proposed (mm)	Remarks	Land area requirement
		2025	2030	2035	2040	2025	2030	2035	2040	2025	2030	2035	2040			
CEPS 8	Portion of Precinct I	20.257	28.235	39.749	55.835	31.553	43.979	61.913	86.969	5 pumps (3W+2S) each of capacity 1150 m <sup>3</sup> /hr + 3 pumps (2W+1S) each of capacity 450 m <sup>3</sup> /hr	Addl. 3 pumps (2W+1S) each of capacity 700 m <sup>3</sup> /hr	Addl. 3 pumps (2W+1S) each of capacity 1000 m <sup>3</sup> /hr	Addl. 3 new pumps (2W+1S) each of capacity 1400 m <sup>3</sup> /hr	1400	In addition will cater pumped discharge from CEPS 9	125m x 80m
CEPS 9	Portion of Precinct I	11.296	15.744	22.164	31.134	11.296	15.744	22.164	31.134	3 pumps (2W+1S) each of capacity 650 m <sup>3</sup> /hr + 2 pumps (1W+1S) each of capacity 350 m <sup>3</sup> /hr	Addl. 2 pumps (1W+1S) each of capacity 450 m <sup>3</sup> /hr	Addl. 2 pumps (1W+1S) each of capacity 750 m <sup>3</sup> /hr	Addl. 3 new pumps (2W+1S) each of capacity 500 m <sup>3</sup> /hr	800		75m x 50m
Terminal PS within CETP 4 area	Portion of Precinct I	43.310	57.758	80.505	113.334	133.347	185.862	261.653	367.540	9 pumps (6W+3S) each of capacity 2500 m <sup>3</sup> /hr + 2 pumps (1W+1S) each of capacity 1200 m <sup>3</sup> /hr	Addl. 3 pumps (2W+1S) each of capacity 2850 m <sup>3</sup> /hr	Addl. 5 pumps (3W+2S) each of capacity 2800 m <sup>3</sup> /hr	Addl. 6 pumps (4W+2S) each of capacity 2950 m <sup>3</sup> /hr	3 nos. each 1600	In addition will cater pumped discharge from CEPS 6 and CEPS 7	200m x 100m



## Annexure 4.9: Calculation for the Size of the Landfill for BSMSN

The calculation given below is applicable for preliminary design of a landfill.

### BASIC DATA

Location	:	Periphery of BSMSN
Waste Generation	:	0.35 kg / capita / day (Bangladesh Standard for cities)
Population considered in 2040:		4.41 million (4,415,240 population)
Waste Generation in 2040	:	0.35 kg x 4.41 x 10 <sup>6</sup> = 500,000 kg/per day <b>1544 tons / day</b>
Design Life	:	<b>Active Period = 20 years</b> <b>Closure and Post Closure Period=25 years</b>
Topography	:	Flat ground

### Landfill Capacity, Landfill Height, Landfill Area

Total Waste Generation in 20 Years (in 2040) = 1544 ton /day x 365x 20= **11.27 x 10<sup>6</sup> tons**

Total Waste Volume (assumed density 0.85 t/cu.m.)

$$V_w = (11.27 \times 10^6) / 0.85 \\ = 13.27 \times 10^6 \text{ cu.m.}$$

Volume of Daily Cover (on the basis of 15 cm soil cover on top and sides for lift height of 1.5 to 2 m)

$$V_{dc} = 0.1 \times 13.27 \times 10^6 \text{ cu.m.} \\ = 1.32 \times 10^6 \text{ cu.m.}$$

Total volume required for components of liner system and of cover system (on the assumption of 1.5m thick liner system (including leachate collection layer) and 1.0 m thick cover system (including gas collection layer) (k = 0.25 for 10 m high landfill, 0.125 for 20 m high landfill and 0.08 for 30 m high landfill)

This is valid for landfills where width of landfill is significantly larger than the height)

$$V_c = 0.125 \times 13.27 \times 10^6 \text{ cu.m. (Considering 20 m height)} \\ = 1.65 \times 10^6 \text{ cu.m.}$$

Volume likely to become available within 10 years due to settlement / biodegradation of waste

$$V_s = m V_w \\ = 0.10 \times 13.27 \times 10^6 \text{ cu.m.} \\ = 1.32 \times 10^6 \text{ cu.m.}$$

(m = 0.10 for biodegradable waste; m will for less than 0.05 for incinerated/inert waste)

First Estimate of Landfill Volume

$$\begin{aligned}
 C_i &= V_w + V_{dc} + V_c - V_s \text{ (cu.m.)} \\
 &= (13.27 + 1.32 + 1.65 - 1.32) \times 10^6 \text{ Cu.m.} \\
 &= 14.92 \times 10^6 \text{ Cu.m.}
 \end{aligned}$$

Likely Shape of Landfill

Rectangular in plan (length : width = 2:1)

Primarily above ground level, partly below ground level.

Area Restrictions : Nil

Possible Maximum Landfill Height = 20 m

$$\text{Area Required} = (14.92 \times 10^6) / 20$$

$$= 0.746 \times 10^6 \text{ sq.m.}$$

$$= 184.34 \text{ Acres}$$

$$= \mathbf{184.0 \text{ (Appx.)}}$$

**Area required for MSW land fill = 184 .0 Acres**

**Total Land requirement :**

**Land for MSW land fill = 184.0 Acres**

**Land for other infrastructure = 30 acres**

**Land for composting plant = 10 acres**

**Land for industrial hazardous waste storage / management = 40 acres**

**Land for biomedical waste management = 10 Acres**

**Total Land for solid waste management = 274.0 Acres of land**

**Landfill Section And Plan :**

Landfill Section and Plan is evaluated on the basis of

- (i) 4:1 side slope for the above-ground portion of the landfill.
- (ii) 2:1 side slope for the below-ground portion of the landfill.
- (iii) Material balance for daily cover, liner and final cover material through excavation at site.
- (iv) Extra space around the waste filling area for infrastructural facilities

## Annexure 4.10 : Cost Estimation of Total Project

Description of Item	Quantity/Unit	Price Without Tax		Phase I Cost Breakdown (Years 1-5)		Phase II Cost Breakdown (Years 6-10)		Phase III Cost Breakdown (Years 11-15)	
		(In Million Taka)	(In Million USD)	(In Million Taka)	(In Million USD)	(In Million Taka)	(In Million USD)	(In Million Taka)	(In Million USD)
<b>Off-Site Infrastructure Costs</b>									
Transport									
Highway Improvements									
Upgrade of Highway	49 Km	14,700	173	0	0	14,700	173	0	0
New Highway Access to BSMSN Boundary	0	0	0	0	0	0	0	0	0
Other (Interchanges/intersections)	10 No.	14,000	165	2000	24	12,000	141	0	0
<b>Sub Total</b>		<b>28,700</b>	<b>338</b>	<b>2,000</b>	<b>24</b>	<b>26,700</b>	<b>314</b>	<b>0</b>	<b>0</b>
Engineering Fees (5%)		1435	16.9	100	1.2	1335	15.7	0	0
Contingency (15%)		4305	50.7	300	3.6	4005	47.1	0	0
Taxes (18%)		5166	60.84	360	4.32	4806	56.52	0	0
<b>Total</b>		<b>39,606</b>	<b>466</b>	<b>2,760</b>	<b>33</b>	<b>36,846</b>	<b>433</b>		
Rail Station Expansion/Improvements									
<b>Upgraded Station subtotal</b>	<b>2 Stations</b>	<b>2,000</b>	<b>24</b>	<b>1,000</b>	<b>12</b>	<b>1000</b>	<b>12</b>	<b>0</b>	<b>0</b>
Engineering Fees (5%)		100	1.2	50	0.6	50	0.6	0	0
Contingency (15%)		300	3.6	150	1.8	150	1.8	0	0
Taxes (18%)		360	4.32	180	2.16	180	2.16	0	0
<b>Total</b>		<b>2,760</b>	<b>33</b>	<b>1,380</b>	<b>17</b>	<b>1,380</b>	<b>17</b>	<b>0</b>	<b>0</b>
Rail Extension/Light Rail Expansion									
Bring Rail Spur from Main Line to BSMSN Boundary	20 Km	8,000	94	8,000	94	0	0	0	0
Construct Rail from BSMSN to Chattogram	46 Km	27,600	325	0	0	27,600	325	0	0
Construct Light Rapid Transit from BSMSN to Chattogram	66 Km	52,800	621	0	0	26,400	311	26,400	311
<b>Sub Total</b>	<b>132 Km</b>	<b>88,400</b>	<b>1,040</b>	<b>8,000</b>	<b>94</b>	<b>54,000</b>	<b>635</b>	<b>26,400</b>	<b>311</b>

Description of Item	Quantity/Unit	Price Without Tax		Phase I Cost Breakdown (Years 1-5)		Phase II Cost Breakdown (Years 6-10)		Phase III Cost Breakdown (Years 11-15)	
		(In Million Taka)	(In Million USD)	(In Million Taka)	(In Million USD)	(In Million Taka)	(In Million USD)	(In Million Taka)	(In Million USD)
Engineering Fees (5%)		4420	52	400	4.7	2700	31.75	1320	15.55
Contingency (15%)		13260	156	1200	14.1	8100	95.25	3960	46.65
Taxes (18%)		15912	187.2	1440	16.92	9720	114.3	4752	55.98
<b>Total</b>		<b>121,992</b>	<b>1,435</b>	<b>11,040</b>	<b>130</b>	<b>74,520</b>	<b>876</b>	<b>36,432</b>	<b>429</b>
Road Network Improvements from Highway to BSMSN Boundaries									
Construct Road (40m)	48 Km	31,150	366	5,525	65	17,925	211	7,700	91
Construct Road (30m)	47.5 Km	19,150	225	12,200	144	6,950	82	0	0
Construct Road (20)	49 Kms	11,400	134	11,400	134	0	0	0	0
<b>Sub Total</b>	<b>144.5 Km</b>	<b>61,700</b>	<b>726</b>	<b>29,125</b>	<b>343</b>	<b>24,875</b>	<b>293</b>	<b>7,700</b>	<b>91</b>
Engineering Fees (5%)		3085	36.3	1456.25	17.15	1243.75	14.65	385	4.55
Contingency (15%)		9255	108.9	4368.75	51.45	3731.25	43.95	1155	13.65
Taxes (18%)		11106	130.68	5242.5	61.74	4477.5	52.74	1386	16.38
<b>Total</b>		<b>85,146</b>	<b>1,002</b>	<b>40,193</b>	<b>473</b>	<b>34,328</b>	<b>404</b>	<b>10,626</b>	<b>126</b>
Electricity Network									
Transmission		4359.5	51.29	700	8.24	750	8.823529	2909.5	34.22941
Engineering Fees (5%)		217.975	2.564412	35	0.411765	37.5	0.441176	145.475	1.711471
Contingency (15%)		653.925	7.693235	105	1.235294	112.5	1.323529	436.425	5.134412
Taxes (18%)		784.71	9.231882	126	1.482353	135	1.588235	523.71	6.161294
<b>Total</b>		<b>6016.11</b>	<b>70.77776</b>	<b>966</b>	<b>11.36471</b>	<b>1035</b>	<b>12.17647</b>	<b>4015.11</b>	<b>47.23659</b>
Water Network									
Raw water intake arrangement including pumping station and approach bridge	3 nos.	1258.0	14.8	450.5	5.3	807.5	9.5	-	-
Raw water transmission main	15 km	807.5	9.5	297.5	3.5	510.0	6.0	-	-
Water treatment plant	3 nos.	2142.0	25.2	765.0	9.0	1377.0	16.2	-	-



Description of Item	Quantity/Unit	Price Without Tax		Phase I Cost Breakdown (Years 1-5)		Phase II Cost Breakdown (Years 6-10)		Phase III Cost Breakdown (Years 11-15)	
		(In Million Taka)	(In Million USD)	(In Million Taka)	(In Million USD)	(In Million Taka)	(In Million USD)	(In Million Taka)	(In Million USD)
Treated water pumping station	4 nos.	484.5	5.7	289.0	3.4	195.5	2.3	-	-
Treated water transmission main	130 km	10115	119.0	7905.0	93.0	2210.0	26.0	-	-
<b>Sub Total</b>		<b>14807.0</b>	<b>174.2</b>	<b>9707.0</b>	<b>114.2</b>	<b>5100.0</b>	<b>60.0</b>	<b>-</b>	<b>-</b>
Engineering Fees (5%)		740.4	8.7	485.4	5.7	255.0	3.0	-	-
Contingency (15%)		2221.1	26.1	1456.1	17.1	765.0	9.0	-	-
Taxes (18%)		2665.3	31.4	1747.3	20.6	918.0	10.8	-	-
<b>Total</b>		<b>20433.8</b>	<b>240.4</b>	<b>13395.8</b>	<b>157.6</b>	<b>7038.0</b>	<b>82.8</b>	<b>-</b>	<b>-</b>
<b>Drainage/Storm Water Network (Not required)</b>									
<b>Wastewater Handling System Network (Not required)</b>									
<b>Off-Site Infrastructure Total</b>		<b>275953.91</b>	<b>3247.178</b>	<b>69734.8</b>	<b>821.9647</b>	<b>155147</b>	<b>1824.976</b>	<b>51073.11</b>	<b>602.2366</b>

Description of Item	Quantity/Unit	Price Without Tax		Phase I Cost Breakdown (Years 1-5)		Phase II Cost Breakdown (Years 6-10)		Phase III Cost Breakdown (Years 11-15)	
		(In Million Taka)	(In Million USD)	(In Million Taka)	(In Million USD)	(In Million Taka)	(In Million USD)	(In Million Taka)	(In Million USD)
<b>On-Site Infrastructure Costs</b>									
Resettlement Costs		598.072858	7.036151271						
<b>Earthworks</b>									
Cut and Fill (cum)	297,343,774	1,414,014	16,635	424,204	4,991	565,606	6,654	424,204	4,991
Embankment (cum)	960,000	4560	54	3,192	38	1,368	16	0	0
<b>Sub Total</b>		<b>1418574</b>	<b>16689.11</b>	<b>427396.3</b>	<b>5028.192</b>	<b>566973.7</b>	<b>6670.279</b>	<b>424204.3</b>	<b>4990.639</b>
Engineering Fees (5%)		63336.6	745.15	19092.2	224.6	25311.85	297.8	18932.6	222.75
Contingency (15%)		190009.8	2235.45	57276.6	673.8	75935.55	893.4	56797.8	668.25
Taxes (18%)		228011.8	2682.54	68731.92	808.56	91122.66	1072.08	68157.36	801.9

Description of Item	Quantity/Unit	Price Without Tax		Phase I Cost Breakdown (Years 1-5)		Phase II Cost Breakdown (Years 6-10)		Phase III Cost Breakdown (Years 11-15)	
		(In Million Taka)	(In Million USD)	(In Million Taka)	(In Million USD)	(In Million Taka)	(In Million USD)	(In Million Taka)	(In Million USD)
<b>Total</b>		<b>1,957,633</b>	<b>23,031</b>	<b>589,807</b>	<b>6,939</b>	<b>782,424</b>	<b>9,205</b>	<b>585,402</b>	<b>6,887</b>
<b>Road Network</b>									
Road (100m)	59 Km	38,700	455	20,124	237	18,576	219	0	0
Road (60m)	29 Km	17,400	205	8,700	102	0	0	8,700	102
Road (40m)	55 Km	19,250	226	10,588	125	4,620	54	4,043	48
Road (30m)	62 Km	24,800	292	4,464	53	15,128	178	5,208	61
Road (20m)	235 Km	47,000	553	8,460	100	28,670	337	9,870	116
<b>Sub Total</b>	<b>440 Km</b>	<b>147,150</b>	<b>1,731</b>	<b>52,336</b>	<b>616</b>	<b>66,994</b>	<b>788</b>	<b>27,821</b>	<b>327</b>
Engineering Fees (5%)		7357.5	86.55	2616.8	30.8	3349.7	39.4	1391.05	16.35
Contingency (15%)		22072.5	259.65	7850.4	92.4	10049.1	118.2	4173.15	49.05
Taxes (18%)		26487	311.58	9420.48	110.88	12058.92	141.84	5007.78	58.86
<b>Total</b>		<b>203,067</b>	<b>2,389</b>	<b>72,224</b>	<b>850</b>	<b>92,452</b>	<b>1,087</b>	<b>38,393</b>	<b>451</b>
<b>Electricity Network</b>									
Generation		88659.5	1043.05	15069.9	177.292	20461.8	240.727	53127.9	625.034
Transmission		69493.7	817.57	14160	166.58	17936.6	211.018	37397	439.964
Distribution		39737.8	467.503	9301.3	109.427	11045.5	129.947	19391	228.129
SCADA and Communication Network		1370	16.1176	0	0	0	0	1370	16.1176
Ancillary Services and Lighting System		4902.5	57.6764	294.1	3.46	775.2	9.12	3833.2	45.0964
Technical Assistance		250	2.94117	250	2.94117	0	0	0	0
<b>Sub Total</b>		<b>208773</b>	<b>2456.15</b>	<b>39775.3</b>	<b>467.936</b>	<b>50969.1</b>	<b>599.635</b>	<b>118028.</b>	<b>1388.57</b>
Engineering Fees (5%)		10438.6	122.807	1988.76	23.3968	2548.45	29.9817	5901.43	69.4285
Contingency (15%)		31315.9	368.422	5966.29	70.1904	7645.36	89.9453	17704.2	208.285
Taxes (18%)		37579.1	442.107	7159.55	84.2285	9174.43	107.934	21245.1	249.942
<b>Total</b>		<b>288106</b>	<b>3389.48</b>	<b>54889.9</b>	<b>645.752</b>	<b>70337.3</b>	<b>827.497</b>	<b>162879.</b>	<b>1916.22</b>
<b>Water Network</b>									

Description of Item	Quantity/Unit	Price Without Tax		Phase I Cost Breakdown (Years 1-5)		Phase II Cost Breakdown (Years 6-10)		Phase III Cost Breakdown (Years 11-15)	
		(In Million Taka)	(In Million USD)	(In Million Taka)	(In Million USD)	(In Million Taka)	(In Million USD)	(In Million Taka)	(In Million USD)
Raw water intake arrangement including pumping station and approach bridge	2 nos.	10089.5	118.7	3468.0	40.8	-	-	6621.5	77.9
Raw water transmission main	8 km	1224.0	14.4	238.0	2.8	-	-	986.0	11.6
Desalination plant	2 nos.	11475.0	135.0	2125.0	25.0	-	-	9350.0	110.0
Treated water pumping station	2 nos.	484.5	5.7	144.5	1.7	-	-	340.0	4.0
Treated water transmission main	110 km	6545.0	77.0	1955.0	23.0	3272.5	38.5	1317.5	15.5
Storage reservoir with pumping arrangement for distribution system	25 nos.	1037.0	12.2	255.0	3.0	416.5	4.9	365.5	4.3
Distribution Main Network	700 km	10710	126.0	2142.0	25.2	4318.0	50.8	4250.0	50.0
Production Well inclusive of Pump House, Chlorination Facility	200 nos.	425.0	5.0	110.5	1.3	144.5	1.7	170.0	2.0
Wastewater recycling line	35 km	5355.0	63.0	510.0	6.0	561.0	6.6	4284.0	50.4
Development of rainwater harvesting system		4250.0	50.0	425.0	5.0	1275.0	15.0	2550.0	30.0
<b>Sub Total</b>		<b>51595.0</b>	<b>607.0</b>	<b>11373.0</b>	<b>133.8</b>	<b>9987.5</b>	<b>117.5</b>	<b>30234.5</b>	<b>355.7</b>
Engineering Fees (5%)		2579.8	30.4	568.7	6.7	499.4	5.9	1511.7	17.8
Contingency (15%)		7739.3	91.1	1706	20.1	1498.1	17.6	4535.2	53.4
Taxes (18%)		9287.1	109.3	2047.1	24.1	1797.8	21.2	5442.2	64.0
<b>Total</b>		<b>71201.2</b>	<b>837.8</b>	<b>15694.8</b>	<b>184.7</b>	<b>13782.8</b>	<b>162.2</b>	<b>41723.6</b>	<b>490.9</b>
<b>Drainage/Storm Water Network</b>									
Trunk storm water drainage network	375 km	12750.0	150.0	3825.0	45.0	3825.0	45.0	5100.0	60.0
Storm water drain outfall structure with flap gate	85 nos.	722.5	8.5	212.5	2.5	221	2.6	289	3.4
Resectioning of existing natural drainage channels	48 km	11220.0	132.0	3366.0	39.6	3366.0	39.6	4488.0	52.8
Provision of sluice gates at outfall end of existing natural drainage channels	13 nos.	1105.0	13.0	552.5	6.5	552.5	6.5	-	-
Drainage pumping station	13 nos.	39363.5	463.1	19635.0	231.0	19728.5	232.1	-	-

Description of Item	Quantity/Unit	Price Without Tax		Phase I Cost Breakdown (Years 1-5)		Phase II Cost Breakdown (Years 6-10)		Phase III Cost Breakdown (Years 11-15)	
		(In Million Taka)	(In Million USD)	(In Million Taka)	(In Million USD)	(In Million Taka)	(In Million USD)	(In Million Taka)	(In Million USD)
Minor storm water drainage network	400 km	8500.0	100.0	2550.0	30.0	2550.0	30.0	3400.0	40.0
<b>Sub Total</b>		<b>73661.0</b>	<b>866.6</b>	<b>30141.0</b>	<b>354.6</b>	<b>30243.0</b>	<b>355.8</b>	<b>13277.0</b>	<b>156.2</b>
Engineering Fees (5%)		3683.1	43.3	1507.1	17.7	1512.2	17.8	663.9	7.8
Contingency (15%)		11049.2	130.0	4521.2	53.2	4536.5	53.4	1991.6	23.4
Taxes (18%)		13259.0	156.0	5425.4	63.8	5443.7	64.0	2389.9	28.1
<b>Total</b>		<b>101652.3</b>	<b>1195.9</b>	<b>41594.7</b>	<b>489.3</b>	<b>41735.4</b>	<b>491.0</b>	<b>18322.4</b>	<b>215.5</b>
<b>Wastewater Handling System</b>									
Sewerage network	400 km	37017.5	435.5	12129.5	142.7	12979.5	152.7	11908.5	140.1
Sewage Pumping Station (SPS) including pumping main	7 nos.	1850.9	21.8	606.5	7.1	649.0	7.7	595.4	7.0
Common effluent pumping station (CEPS) including pumping main	11 nos.	5552.6	65.3	1819.4	21.4	1946.9	22.9	1786.3	21.0
Sewage treatment plant (STP)	2 nos.	6663.2	78.4	2183.3	25.7	2336.3	27.5	2143.5	25.2
Common effluent treatment plant (CETP)	4 nos.	51084.2	601.0	16738.7	196.9	17911.7	210.8	16433.7	193.3
<b>Sub Total</b>		<b>37017.5</b>	<b>435.5</b>	<b>12129.5</b>	<b>142.7</b>	<b>12979.5</b>	<b>152.7</b>	<b>11908.5</b>	<b>140.1</b>
Engineering Fees (5%)		1850.9	21.8	606.5	7.1	649.0	7.7	595.4	7.0
Contingency (15%)		5552.6	65.3	1819.4	21.4	1946.9	22.9	1786.3	21.0
Taxes (18%)		6663.2	78.4	2183.3	25.7	2336.3	27.5	2143.5	25.2
<b>Total</b>		<b>51084.2</b>	<b>601.0</b>	<b>16738.7</b>	<b>196.9</b>	<b>17911.7</b>	<b>210.8</b>	<b>16433.7</b>	<b>193.3</b>
<b>Gas Network</b>									
A customer having 100000m3 montly,300m3/hr,0.2 MMSCFD and 500 meter service line (Customer operation hour=16 hr/day)									
Service line=500meter (3")	1900	0.95	0.0112	0.475	0.005588	<b>0.285</b>	0.003353	0.19	0.002235
Internal line-200meter (4")	2700	0.54	0.0064	0.27	0.003176	<b>0.162</b>	0.001906	0.108	0.001271
Accessories Cost	L.S	0.45	0.0053	0.225	0.002647	<b>0.135</b>	0.001588	0.09	0.001059
Construction Cost	L.S	0.1	0.0012	0.05	0.000588	<b>0.03</b>	0.000353	0.02	0.000235
CP/line protection cost	As per design	0.3	0.0035	0.15	0.001765	<b>0.09</b>	0.001059	0.06	0.000706

Description of Item	Quantity/Unit	Price Without Tax		Phase I Cost Breakdown (Years 1-5)		Phase II Cost Breakdown (Years 6-10)		Phase III Cost Breakdown (Years 11-15)	
		(In Million Taka)	(In Million USD)	(In Million Taka)	(In Million USD)	(In Million Taka)	(In Million USD)	(In Million Taka)	(In Million USD)
CMS/ Gas Station cost ( C type)	As per design	2	0.0235	1	0.011765	<b>0.6</b>	0.007059	0.4	0.004706
Security money as per approved monthly Gas load	10.7 tk/m3	3.21	0.0378	1.605	0.018882	<b>0.963</b>	0.011329	0.642	0.007553
Total cost for one customer		7.55	0.0888	3.775	0.044412	<b>2.265</b>	0.026647	1.51	0.017765
Total cost for 925 customers	925	6983.75	82.1618	3491.875	41.08088	<b>2095.13</b>	24.64853	1396.75	16.43235
<b>A customer having 600000m3 montly,1770m3/hr,1 MMSCFD and 500 meter service line (Customer operation hour=16 hr/day)</b>									
Service line=500meter (4")	2700	1.35	0.0159	0.675	0.007941	<b>0.405</b>	0.004765	0.27	0.003176
Internal line-200meter (6")	4800	0.96	0.0113	0.48	0.005647	<b>0.288</b>	0.003388	0.192	0.002259
Accessories Cost	L.S	0.5	0.0059	0.25	0.002941	<b>0.15</b>	0.001765	0.1	0.001176
Construction Cost	L.S	0.2	0.0024	0.1	0.001176	<b>0.06</b>	0.000706	0.04	0.000471
CP/line protection cost	As per design	0.4	0.0047	0.2	0.002353	<b>0.12</b>	0.001412	0.08	0.000941
CMS/ Gas Station cost (F1 type)	As per design	3	0.0353	1.5	0.017647	<b>0.9</b>	0.010588	0.6	0.007059
Security money as per approved monthly Gas load	10.7 tk/m3	19.26	0.2266	9.63	0.113294	<b>5.778</b>	0.067976	3.852	0.045318
Total cost for one customer		25.67	0.3020	12.835	0.151	<b>7.701</b>	0.0906	5.134	0.0604
Total cost for 150 customers	150	3850.5	45.3000	1925.25	22.65	<b>1155.15</b>	13.59	770.1	9.06
<b>A customer having 998400m3 montly,4000m3/hr,1.7 MMSCFD and 500 meter service line (Customer operation hour=24 hr/day)</b>									
Service line=500meter (4")	2700	1.35	0.0159	0.675	0.007941	<b>0.405</b>	0.004765	0.27	0.003176
Internal line-200meter (6")	4800	0.96	0.0113	0.48	0.005647	<b>0.288</b>	0.003388	0.192	0.002259
Accessories Cost	L.S	0.5	0.0059	0.25	0.002941	<b>0.15</b>	0.001765	0.1	0.001176
Construction Cost	L.S	0.2	0.0024	0.1	0.001176	<b>0.06</b>	0.000706	0.04	0.000471
CP/line protection cost	As per design	0.6	0.0071	0.3	0.003529	<b>0.18</b>	0.002118	0.12	0.001412
CMS/ Gas Station cost (F1 type)	As per design	3	0.0353	1.5	0.017647	<b>0.9</b>	0.010588	0.6	0.007059
Security money as per approved monthly Gas load	10.7 tk/m3	32.04864	0.3770	16.02432	0.188521	<b>9.61459</b>	0.113113	6.409728	0.075409
Total cost for one customer		38.65864	0.4548	19.32932	0.227404	<b>11.5976</b>	0.136442	7.731728	0.090962
Total cost for 103 customers	103	3981.83992	46.8452	1990.92	23.42259	<b>1194.55</b>	14.05355	796.368	9.369035

Description of Item	Quantity/Unit	Price Without Tax		Phase I Cost Breakdown (Years 1-5)		Phase II Cost Breakdown (Years 6-10)		Phase III Cost Breakdown (Years 11-15)	
		(In Million Taka)	(In Million USD)	(In Million Taka)	(In Million USD)	(In Million Taka)	(In Million USD)	(In Million Taka)	(In Million USD)
<b>A customer having 998400m3 montly,4000m3/hr,1.7 MMSCFD and 500 meter service line (Customer operation hour=24 hr/day)</b>									
Service line=500meter (6")	4800	2.4	0.0282	1.2	0.014118	<b>0.72</b>	0.008471	0.48	0.005647
Internal line-200meter (8")	6000	1.2	0.0141	0.6	0.007059	<b>0.36</b>	0.004235	0.24	0.002824
Accessories Cost	L.S	0.6	0.0071	0.3	0.003529	<b>0.18</b>	0.002118	0.12	0.001412
Construction Cost	L.S	0.3	0.0035	0.15	0.001765	<b>0.09</b>	0.001059	0.06	0.000706
CP/line protection cost	As per design	0.8	0.0094	0.4	0.004706	<b>0.24</b>	0.002824	0.16	0.001882
CMS/ Gas Station cost (F3 type)	As per design	4.5	0.0529	2.25	0.026471	<b>1.35</b>	0.015882	0.9	0.010588
Security money as per approved monthly Gas load	10.7 tk/m3	32.04864	0.3770	16.02432	0.188521	<b>9.61459</b>	0.113113	6.409728	0.075409
Total cost for one customer		41.84864	0.4923	20.92432	0.246168	<b>12.5546</b>	0.147701	8.369728	0.098467
Total cost for 22 customers	22	920.67008	10.8314	460.335	5.415706	<b>276.201</b>	3.249424	184.134	2.166283
<b>Grand Total (for 1200 different capacity customers)</b>	<b>1200</b>	<b>15736.76</b>	<b>185.1384</b>	<b>7868.38</b>	<b>92.56918</b>	<b>4721.03</b>	<b>55.54151</b>	<b>3147.352</b>	<b>37.02767</b>
Engineering Fees (5%)		786.838	9.256918	393.419	4.628459	236.0514	2.777075	157.3676	1.851384
Contingency (15%)		2360.514	27.77075	1180.257	13.88538	708.1542	8.331226	472.1028	5.554151
Taxes (18%)		2832.617	33.3249	1416.308	16.66245	849.785	9.997471	566.5234	6.664981
<b>Total</b>		<b>21716.73</b>	<b>255.4909</b>	<b>10858.36</b>	<b>127.7455</b>	<b>6515.019</b>	<b>76.64728</b>	<b>4343.346</b>	<b>51.09819</b>
Solid Waste									
<b>Solid Waste Management</b>	<b>142.5 acres</b>	<b>1884.0</b>	<b>22.17</b>	<b>328.95</b>	<b>3.87</b>	<b>1156.0</b>	<b>13.6</b>	<b>399.95</b>	<b>4.7</b>
Engineering Fees (5%)		94.2	1.1085	16.4475	0.1935	57.8	0.68	19.9975	0.235
Contingency (15%)		282.6	3.3255	49.3425	0.5805	173.4	2.04	59.9925	0.705
Taxes (18%)		339.12	3.9906	59.211	0.6966	208.08	2.448	71.991	0.846
<b>Total</b>		<b>2599.92</b>	<b>30.5946</b>	<b>453.951</b>	<b>5.3406</b>	<b>1595.28</b>	<b>18.768</b>	<b>551.931</b>	<b>6.486</b>
<b>Fencing/Open Space/Landscaping</b>									
<b>Plantation Cost</b>		<b>78.092</b>	<b>0.918729</b>	<b>78.092</b>	<b>0.918729</b>	-	-	-	-
Engineering Fees (5%)		3.9046	0.045936	3.9046	0.045936				

Description of Item	Quantity/Unit	Price Without Tax		Phase I Cost Breakdown (Years 1-5)		Phase II Cost Breakdown (Years 6-10)		Phase III Cost Breakdown (Years 11-15)	
		(In Million Taka)	(In Million USD)	(In Million Taka)	(In Million USD)	(In Million Taka)	(In Million USD)	(In Million Taka)	(In Million USD)
Contingency (15%)		11.7138	0.137809	11.7138	0.137809				
Taxes (18%)		14.05656	0.165371	14.05656	0.165371				
<b>Total</b>		<b>107.767</b>	<b>1.267846</b>	<b>107.767</b>	<b>1.267846</b>				
<b>On-Site Infrastructure Total</b>		<b>2697765.71</b>	<b>31738.54</b>	<b>802369.1</b>	<b>9439.91</b>	<b>1026753</b>	<b>12078.9</b>	<b>868048.9</b>	<b>10211.59</b>
<b>Project Total Cost (on site and off site)</b>		<b>2973719.62</b>	<b>34985.72</b>	<b>872103.9</b>	<b>10261.88</b>	<b>1181900</b>	<b>13903.87</b>	<b>919122</b>	<b>10813.82</b>

## Annexure 5.1: Affected Households

### a. Bamonsundor to BEZA Road

SI No.	Name	National ID	Contact No.	Address
1	Md. Golam Moula	1515389708549	1815118944	Mauza: Dokkhin Moghadia, Village:Dokkhin Moghadia , Ward:03,, Union: 16 no.Shahebkhal, Upz: Mirsarai, Dist.: Chittagong
2	Md. Mozammal Hossain	1515383000005	1895221870	Mauza: Dokkhin Moghadia, Village:Dokkhin Moghadia , Ward:03,, Union: 16 no.Shahebkhal, Upz: Mirsarai, Dist.: Chittagong
3	Mohammad Abdul Hi	1515383481758	1869548676	House : 89, Mouza: Dakkhin Maghadea, Village : Maghadea, Ward : 03, Union: Shaherkhali, Upz- Mirsarai, Dist : Chittagong
4	Seikh Ahmed	1515383488366	1813991036	Mouza: Doskin Mogadia, Village: Mogadia, Ward: 03, Union: Saherkhali, Upz: Mirsarai, Dist.: Chittagong
5	Bebe Hazaea	1515353527105	1863701471	Mouza: Mogadia, Village: Dokkhin Mogadia, Ward: 02, Union: Saherkhali, Upz: Mirsarai, Dist.: Chittagong
6	Md. Ismail	1515383488469	1829461118	House no : 56, Mouza: Moghadia, Village: Doskin Moghadia, Ward: 02, Union: Saherkhali, Upz: Mirsarai, Dist.: Chittagong
7	Md Razaul Karim	1515347703219	1815504570	House no:243 , Mouza:Dakkhin moghadia, Village: Dakkhin moghadia, Ward:03, Union:Saherkhali, Upz:Mirsarai, Dist:Chittagong
8	Md. Iqbal Hossain	1991155383000010	1825661745	Mouza: Doskin Mogadia, Village: Mogadia, Ward: 03, Union:Saherkhali , Upz: Mirsarai, Dist.: Chittagong
9	Mobarak Hossain	152860902231	1839476674	Mouza: Doskin Mogadia, Village: Mogadia, Ward: 03, Union: Saherkhali, Upz: Mirsarai, Dist.: Chittagong
10	Md Nur Uddin	1515383481638	1834248164	House : 26, Mouza: Dakkhin Maghadea, Village : Maghadea, Ward : 03, Union: Shaherkhali, Upz- Mirsarai, Dist : Chittagong
11	Md Bachu Mia	1515383481618	1859378149	Mouza: Dakkhin Maghadea, Village: Dakkhin Maghadea, Ward: 03, Union: Saherkhali, Upz: Mirsarai, Dist.: Chittagong
12	Anowar Hossain	1515383481676	1836634558	Mouza: Doskin Mogadia, Village: Mogadia, Ward: 03, Union: Saherkhali, Upz: Mirsarai, Dist.: Chittagong
13	Sahadat Hossain	1515383000003	1642762902	Mauza: Dokkhin Moghadia, Village:Dokkhin Moghadia , Ward:03,, Union: 16 no.Shahebkhal, Upz: Mirsarai, Dist.: Chittagong
14	Giyas Uddin	1515383481621	1845326862	House no : 59, Mouza: Moghadia, Village: Doskin Moghadia, Ward: 03, Union: Saherkhali, Upz: Mirsarai, Dist.: Chittagong
15	Nur Uddin	1515383481619	1857911784	House no : 59, Mouza: Moghadia, Village: Doskin Moghadia, Ward: 03, Union: 16, Saherkhali, Upz: Mirsarai, Dist.: Chittagong
16	Md Nasir Uddin	1515383481661	1859378149	Mouza: Dakkhin Maghadea, Village: Dakkhin Maghadea, Ward: 03, Union: Saherkhali, Upz: Mirsarai, Dist.: Chittagong
17	Md. Abul Kashem	1515383488489	1845834658	House no : 006, Mouza: Moghadia, Village:Doskin Moghadia, Ward: 02, Union: Saherkhali, Upz: Mirsarai, Dist.: Chittagong

SI No.	Name	National ID	Contact No.	Address
18	Abdul Malek	195415383008283	1843686209	Mouza:Dakkhin moghadia, Village: Dakkhin moghadia, Ward:03, Union:Saherkhali, Upz:Mirsarai, Dist:Chittagong
19	Md. Mohiuddin	1515383481649	18262257634	Mouza: Doskin Mogadia, Village: Mogadia, Ward: 03, Union: Saherkhali, Upz: Mirsarai, Dist.: Chittagong
20	Md Arif Mia	1515383481659	1865310040	Mouza: Dakkhin Maghadea, Village: Dakkhin Maghadea, Ward: 03, Union: Saherkhali, Upz: Mirsarai, Dist.: Chittagong
21	Akrumul Hoque	1515383481655	1836200721	Mouza: Doskin Mogadia, Village: Mogadia, Ward: 07, Union: , Upz: Mirsarai, Dist.: Chittagong
22	Md. Jagir Hossain	19921515347000200	1832508801	House : 09, Mouza: Dakkhin Maghadea, Village : Maghadea, Ward : 03, Union: Shaherkhali, Upz- Mirsarai, Dist : Chittagong
23	Md. Samsu Uddin	1515383481632	1815512761	Mauza: Dokkhin Moghadia, Village:Dokkhin Moghadia , Ward:03,, Union: 16 no.Shahebkhal, Upz: Mirsarai, Dist.: Chittagong
24	Shala Ahammad	1515383481629		House No: 56, Mouza: Mogadia, Village: South Mogadia, Ward: 03, Union: Saherkhali, Upz: Mirsarai, Dist.: Chittagong
25	Md. Mohi Uddin	1515383488144	1817257322	Mouza: Mogadia, Village: Dokkhin Mogadia, Ward: 02, Union: Saherkhali, Upz: Mirsarai, Dist.: Chittagong
26	Md. Azmir Hosain	1.51538E+12	1824939236	Mauza: Dokkhin Moghadia, Village:Dokkhin Moghadia , Ward:03,, Union: 16 no.Shahebkhal, Upz: Mirsarai, Dist.: Chittagong

#### b. Sheikh Hasina Avenue

SI No.	Name	National Id	Contact No.	Address
1	Rabiul Hossen	1515383484973	01876411768	Mouza: South Magadia, Village: South Magadia, Ward: 01, Union: Shahebkhal, Upz: Mirsarai, Dist.: Chittagong
2	Jamal Hossain	1515383482391	01840257264	Mouza: South Magadia, Village: Kajir Talur, Ward: 01, Union: Shahebkhal, Upz: Mirsarai, Dist.: Chittagong
3	Jebal Hoque	1515383482346	01858901143	Mouza: South Magadia, Village: Kajir Talur, Ward: 01, Union: Shahebkhal, Upz: Mirsarai, Dist.: Chittagong
4	Sayad Hossen	19921515383000000	01843628655	Mouza: South Magadia, Village: Kajir Talur, Ward: 01, Union: Shahebkhal, Upz: Mirsarai, Dist.: Chittagong
5	Md Iftekher	1518695113602	01854393827	Mouza: South Magadia, Village: Kajir Talur, Ward: 01, Union: Shahebkhal, Upz: Mirsarai, Dist.: Chittagong
6	Saleh Ahamed	1515383482352	01853011169	Mouza: South Magadia, Village: Kajir Talur, Ward: 01, Union: Shahebkhal, Upz: Mirsarai, Dist.: Chittagong
7	Jahangir	1525317728744	01811296191	Mouza: South Magadia, Village: Kajir Talur, Ward: 01, Union: Shahebkhal, Upz: Mirsarai, Dist.: Chittagong
8	Nur Banu	19921515383000000	01836589060	Mouza: South Magadia, Village: Kajir Talur, Ward: 01, Union: Shahebkhal, Upz: Mirsarai, Dist.: Chittagong
9	Aman Hossen	1515383482344	01840634577	Mouza: South Magadia, Village: Kajir Talur, Ward: 01, Union: Shahebkhal, Upz: Mirsarai, Dist.: Chittagong
10	Md. Soleman	1515383482334	01865581735	Mouza: South Magadia, Village: Kajir Talur, Ward: 01, Union: Shahebkhal, Upz: Mirsarai, Dist.: Chittagong
11	Md Delowar	1515371720158	01874899380	Mouza: South Magadia, Village: Kajir Talur, Ward: 01, Union: Shahebkhal, Upz: Mirsarai, Dist.: Chittagong
12	Md Mostafa	1515383482392	01846732450	Mouza: South Magadia, Village: Kajir Talur, Ward: 01, Union: Shahebkhal, Upz: Mirsarai, Dist.: Chittagong
13	Henju Mai	1515383482342	01874899380	Mouza: South Magadia, Village: Kajir Talur, Ward: 01, Union: Shahebkhal, Upz: Mirsarai, Dist.: Chittagong
14	Shamsul Hoque	1515383482324	01830093400	Mouza: South Magadia, Village: Kajir Talur, Ward: 01, Union: Shahebkhal, Upz: Mirsarai, Dist.: Chittagong
15	Moksud Ahmed	1515383482327	01830093400	Mouza: South Magadia, Village: Kajir Talur, Ward: 01, Union: Shahebkhal, Upz: Mirsarai, Dist.: Chittagong
16	Anamul Hoque	1515383482310	01860468406	Mouza: South Magadia, Village: Kajir Talur, Ward: 01, Union: Shahebkhal, Upz: Mirsarai, Dist.: Chittagong
17	Michir Ahmed	1515383482311	01874768371	Mouza: South Magadia, Village: Kajir Talur, Ward: 01, Union: Shahebkhal, Upz: Mirsarai, Dist.: Chittagong
18	Md Anwar Hossen	1592038901700	01813131974	Mouza: South Magadia, Village: Kajir Talur, Ward: 01, Union: Shahebkhal, Upz: Mirsarai, Dist.: Chittagong
19	Monir Hossain	1515383482308	01875963967	Mouza: South Magadia, Village: Kajir Talur, Ward: 01, Union: Shahebkhal, Upz: Mirsarai, Dist.: Chittagong
20	Abdul Kalam	1590603560348	01815445725	Mouza: South Magadia, Village: Kajir Talur, Ward: 01, Union: Shahebkhal, Upz: Mirsarai, Dist.: Chittagong
21	Mir Sorab	1515383482331	01836257002	Mouza: South Magadia, Village: Kajir Talur, Ward: 01, Union: Shahebkhal, Upz: Mirsarai, Dist.: Chittagong
22	Md Kamal Uddin	1515383482329	01830121286	Mouza: South Magadia, Village: Kajir Talur, Ward: 01, Union: Shahebkhal, Upz: Mirsarai, Dist.: Chittagong
23	Abu Salak	1515371720140	01839046018	Mouza: South Magadia, Village: Magadia, Ward: 09, Union: Magadia, Upz: Mirsarai, Dist.: Chittagong



SI No.	Name	National Id	Contact No.	Address
24	Md Shahab Uddin	19921515371000100	01839782328	Mouza: South Magadia, Village: Magadia, Ward: 09, Union: Magadia, Upz: Mirsarai, Dist.: Chittagong
25	Md Abul Kalam	1515371720281	01832944450	Mouza: South Magadia, Village: South Magadia, Ward: 01, Union: Shahebkhal, Upz: Mirsarai, Dist.: Chittagong
26	Sahab Uddin	19921515371000100	01830484529	Mouza: South Magadia, Village: South Magadia, Ward: 01, Union: Shahebkhal, Upz: Mirsarai, Dist.: Chittagong
27	Anwar Hossain Jaynal	1515371720139	01882812139	Mouza: Maghadia, Village : Maghadia, Ward : 09, Union: Maghadia, Upz- Mirsarai, Dist : Chittagong
28	Md. Khan Shaheb	1515371720145	01818638212	Mouza: Maghadia, Village : Maghadia, Ward : 09, Union: Maghadia, Upz- Mirsarai, Dist : Chittagong
29	Abdul Haque	1515371720133	01848150714	Mouza: Maghadia, Village : Maghadia, Ward : 09, Union: Maghadia, Upz- Mirsarai, Dist : Chittagong
30	Md. Hiru	1592824591579	01830195122	Mouza: Maghadia, Village : Maghadia, Ward : 09, Union: Maghadia, Upz- Mirsarai, Dist : Chittagong
31	Md Milon	1592824591578	01813312821	Mouza: Maghadia, Village : Maghadia, Ward : 09, Union: Maghadia, Upz- Mirsarai, Dist : Chittagong
32	Md Nur Islam	1515371720123	01864596525	Mouza: Maghadia, Village : Maghadia, Ward : 09, Union: Maghadia, Upz- Mirsarai, Dist : Chittagong
33	Manoara Begum	1515371720144	01852326340	Mouza: Maghadia, Village : Maghadia, Ward : 09, Union: Maghadia, Upz- Mirsarai, Dist : Chittagong
34	Md Nur alam	1515371157792	01817775755	Mouza: Maghadia, Village : Maghadia, Ward : 09, Union: Maghadia, Upz- Mirsarai, Dist : Chittagong
35	Abdul Jabbar	1515371157868		Mouza: Maghadia, Village : Maghadia, Ward : 09, Union: Maghadia, Upz- Mirsarai, Dist : Chittagong
36	Md Kinu Miya	19891515371000000	01827281699	Mouza: Maghadia, Village : Maghadia, Ward : 09, Union: Maghadia, Upz- Mirsarai, Dist : Chittagong
37	Sanu Akter	19761515371000000	01864545564	Mouza: Maghadia, Village : Maghadia, Ward : 09, Union: Maghadia, Upz- Mirsarai, Dist : Chittagong
38	Md Janimia	1515371157831	01863599797	Mouza: Maghadia, Village : Maghadia, Ward : 09, Union: Maghadia, Upz- Mirsarai, Dist : Chittagong
39	Rokeya Begum	19921515371000000	01820903425	Mouza: Maghadia, Village : Maghadia, Ward : 09, Union: Maghadia, Upz- Mirsarai, Dist : Chittagong
40	Asma Hena Seme	19941515353000000	01712635378	Mouza: East Mayani, Village : Soiyali, Ward : 01, Union: Mayani, Upz- Mirsarai, Dist : Chittagong
41	Mst. Salma Begum	1515383482229	01831789928	House: 4155383, Moiza : Maghadia, Village : Maghadia, Ward : 09, Union: Maghadia, Upz- Mirsarai, Dist : Chittagong
42	Md Abdul Karim	1515371720150	01831581066	Mouza: South Maghadia, Village : South Maghadia, Ward : 01, Union: Sahera, Upz- Mirsarai, Dist : Chittagong
43	Md Rafikul Islam	1515371720934	01865463862	Mouza: South Maghadia, Village : South Maghadia, Ward : 01, Union: Saher Khali, Upz- Mirsarai, Dist : Chittagong
44	Mst Amena Khatun	15153883		Mouza: South Maghadia, Village : South Maghadia, Ward : 01, Union: Saher Khali, Upz- Mirsarai, Dist : Chittagong
45	Md Alauddin	1515383482301	01833276676	Mouza: South Maghadia, Village : South Maghadia, Ward : 01, Union: Saher Khali, Upz- Mirsarai, Dist : Chittagong
46	Md Daud Jaman	19831515371000000	01845908659	Mouza: South Maghadia, Village : South Maghadia, Ward : 01, Union: Saher Khali, Upz- Mirsarai, Dist : Chittagong
47	Md Mofizer Rahaman	1515371720154	0183929339	Mouza: South Maghadia, Village : South Maghadia, Ward : 01, Union: Saher Khali, Upz- Mirsarai, Dist : Chittagong
48	Jushnawara Begum	19861515371000000	01835000272	Mouza: South Maghadia, Village : South Maghadia, Ward : 01, Union: Saher Khali, Upz- Mirsarai, Dist : Chittagong
49	Md Ismail	19871515383000000	01860625886	Mouza: South Maghadia, Village : South Maghadia, Ward : 01, Union: Saher Khali, Upz- Mirsarai, Dist : Chittagong
50	Md Shahab Uddin	19831515359000000	01878662559	Mouza: South Maghadia, Village : South Maghadia, Ward : 01, Union: Saher Khali, Upz- Mirsarai, Dist : Chittagong
51	Md Sirazul Islam	1515383482208	01838174874	Mouza: South Maghadia, Village : South Maghadia, Ward : 01, Union: Saher Khali, Upz- Mirsarai, Dist : Chittagong
52	Md Abdul Kamal	1590603560348	01815445725	Mouza: South Maghadia, Village : South Maghadia, Ward : 01, Union: Saher Khali, Upz- Mirsarai, Dist : Chittagong
53	MD JAHANGIR ALAM	19741515371000000	01826643821	Mouza:South Mogadia, village:South Mogadia, Ward:1, Union:Shaher khali, UZP:Mirshori, Dist:Chittagong
54	MD Liton	1515371720153	01770133938	Mouza:South Mogadia, village:South Mogadia, Ward:1, Union:Shaher khali, UZP:Mirshori, Dist:Chittagong
55	Md yusuf	151371720147	01770133938	Mouza:South Mogadia, village:South yusuf, Ward:1, Union:Shaher khali, UZP:Mirshori, Dist:Chittagong
56	MD SHAHIN	19921515371000000	01836780494	Mouza:South Mogadia, village:South Mogadia, Ward:1, Union:Shaher khali, UZP:Mirshori, Dist:Chittagong
57	ALA UDDIN	1515383482315	01853691671	Mouza:South Mogadia, village:South Mogadia, Ward:1, Union:Shaher khali, UZP:Mirshori, Dist:Chittagong
58	Ayub Khan	1515383482321	01885227862	Mouza:South Mogadia, village:South Mogadia, Ward:1, Union:Shaher khali, UZP:Mirshori, Dist:Chittagong
59	Johorul Hoque	1515383482322	01833261554	Mouza:South Mogadia, village:South Mogadia, Ward:1, Union:Shaher khali, UZP:Mirshori, Dist:Chittagong
60	Fazal Karim	1515383482317	01812741989	Mouza:South Mogadia, village:South Mogadia, Ward:7, Union:Shaher khali, UZP:Mirshori, Dist:Chittagong
61	Md Manik	1515328411521	01877197815	Mouza:South Mogadia, village:South Mogadia, Ward:1, Union:Shaher khali, UZP:Mirshori, Dist:Chittagong

SI No.	Name	National Id	Contact No.	Address
62	Sha Alam	1515383482307	01840939741	Mouza:South Mogadia, village:South Mogadia, Ward:1, Union:Shaher khali, UZP:Mirshori, Dist:Chittagong
63	Md. Ayub Khan	19861515383000000	01833253722	Mouza:South Mogadia, village:South Mogadia, Ward:1, Union:Shaher khali, UZP:Mirshori, Dist:Chittagong
64	Md Kamal Hossain	1592823589428	01828507475	Mouza:South Mogadia, village:South Mogadia, Ward:1, Union:Shaher khali, UZP:Mirshori, Dist:Chittagong
65	Joynab Biya	1515383482350	01823842768	Mouza:South Mogadia, village:South Mogadia, Ward:1, Union:Shaher khali, UZP:Mirshori, Dist:Chittagong
66	Md Rahim	19811515383000000		Mouza:South Mogadia, village:South Mogadia, Ward:1, Union:Shaher khali, UZP:Mirshori, Dist:Chittagong
67	Didar Hossen	19931515383000000	01855697475	Mouza:South Mogadia, village:South Mogadia, Ward:1, Union:Shaher khali, UZP:Mirshori, Dist:Chittagong
68	Mukter Hossain	19901515383000000	01855279742	Mouza:South Mogadia, village:South Mogadia, Ward:1, Union:Shaher khali, UZP:Mirshori, Dist:Chittagong
69	Md. Ibrahim Khalil	1515371157811	01849262435	Mouza:South Mogadia, village:South Mogadia, Ward:1, Union:Shaher khali, UZP:Mirshori, Dist:Chittagong

### c. North to Sheikh Hasina Saroni Road

SI No.	Name	National Id	Contact No.	Address
1	Md. Kamal Uddin	1525312424944	01819644442	Mouza: Kismat Jafrabad, Village: Tarakatia, Ward: 05, Union: Mirsarai Pourashava, Upz: Mirsarai, Dist.:Chattogram
2	Nurul islam	1525315479696	01868944030	Mouza: Kismat Jafrabad, Village: Tarakatia, Ward: 05, Union: Mirsarai Pourashava, Upz: Mirsarai, Dist.:Chattogram
3	Komola Begam	1525315479694	01813728352	Mouza: Kismat Jafrabad, Village: Tarakatia, Ward: 05, Union: Mirsarai Pourashava, Upz: Mirsarai, Dist.:Chattogram
4	Abu Jafor	1515365684183	01867913073	Mouza: Kismat Jafrabad, Village: Tarakatia, Ward: 05, Union: Mirsarai Pourashava, Upz: Mirsarai, Dist.:Chattogram
5	Rabiul Hossain			Mouza: Paschim Molyaish, Village: 10 Mithanala, Ward: 09, Union: 10 Mithainala, Upz: Mirsarai, Dist.:Chattogram
6	Md Mosharof Hossain	1515365509957	01814175527	Mouza: Paschim Molyaish, Village: 10 Mithanala, Ward: 09, Union: 10 Mithainala, Upz: Mirsarai, Dist.:Chattogram
7	Md shoriful Islam	1515341635431	018063624419	Mouza: Paschim Molyaish, Village: 10 Mithanala, Ward: 09, Union: 10 Mithainala, Upz: Mirsarai, Dist.:Chattogram
8	Afroza Begam	1515365501954	01889484459	Mouza: Paschim Molyaish, Village: 10 Mithanala, Ward: 09, Union: 10 Mithainala, Upz: Mirsarai, Dist.:Chattogram
9	Md Abul Kashem			Mouza: Paschim Molyaish, Village: 10 Mithanala, Ward: 09, Union: 10 Mithainala, Upz: Mirsarai, Dist.:Chattogram
10	Md Abu Zafor	1515365509115	01883607518	Mouza: Paschim Molyaish, Village: 10 Mithanala, Ward: 09, Union: 10 Mithainala, Upz: Mirsarai, Dist.:Chattogram
11	Md Jakir Hossain		01915557849	Mouza: Paschim Molyaish, Village: 10 Mithanala, Ward: 09, Union: 10 Mithainala, Upz: Mirsarai, Dist.:Chattogram
12	Md Nurul Karim	1515365501601		Mouza: Paschim Molyaish, Village: 10 Mithanala, Ward: 09, Union: 10 Mithainala, Upz: Mirsarai, Dist.:Chattogram
13	Md Shahidul Miya			Mouza: Paschim Molyaish, Village: 10 Mithanala, Ward: 09, Union: 10 Mithainala, Upz: Mirsarai, Dist.:Chattogram
14	Golam Mortofa		01710108683	Mouza: Paschim Molyaish, Village: 10 Mithanala, Ward: 09, Union: 10 Mithainala, Upz: Mirsarai, Dist.:Chattogram
15	Anowara Begum	1525315479824	01819640337	Mouza: Paschim Molyaish, Village: 10 Mithanala, Ward: 09, Union: 10 Mithainala, Upz: Mirsarai, Dist.:Chattogram
16	Md Fazlul Karim	19711515365023861	01860613644	Mouza: Paschim Molyaish, Village: 10 Mithanala, Ward: 09, Union: 10 Mithainala, Upz: Mirsarai, Dist.:Chattogram
17	Bhaba Ranjon Nath		01869723581	Mouza: Paschim Molyaish, Village: 10 Mithanala, Ward: 09, Union: 10 Mithainala, Upz: Mirsarai, Dist.:Chattogram
18	Nur Hossain	1515359420080	01815119734	Mouza: Raghobpur, Village:Tarakatia , Ward: 09, Union: Mirsarai Porasabha, Upz: Mirsarai, Dist.:Chattogram
19	Giyas Uddin	1515365509941	01814456033	Mouza: Raghobpur, Village:Tarakatia , Ward: 09, Union: Mirsarai Porasabha, Upz: Mirsarai, Dist.:Chattogram
20	Liton Kumar Das	19791515310006167	01849600089	Mouza: Raghobpur, Village:Tarakatia , Ward: 09, Union: Mirsarai Porasabha, Upz: Mirsarai, Dist.:Chattogram
21	Potul Rani das			Mouza: Raghobpur, Village:Tarakatia , Ward: 09, Union: Mirsarai Porasabha, Upz: Mirsarai, Dist.:Chattogram
22	Ruma Rani das	1515365509905	01850271667	Mouza: Raghobpur, Village:Tarakatia , Ward: 09, Union: Mirsarai Porasabha, Upz: Mirsarai, Dist.:Chattogram
23	Mathu Rani Das	1515365509906	01829487091	Mouza: Raghobpur, Village:Tarakatia , Ward: 09, Union: Mirsarai Porasabha, Upz: Mirsarai, Dist.:Chattogram
24	Sumon	19841515310006816	01816835602	Mouza: Raghobpur, Village:Tarakatia , Ward: 09, Union: Mirsarai Porasabha, Upz: Mirsarai, Dist.:Chattogram

SI No.	Name	National Id	Contact No.	Address
25	Jahanara Begam	1515365509555	01864568859	Mouza: Raghobpur, Village:Tarakatia , Ward: 09, Union: Mirsarai Porasabha, Upz: Mirsarai, Dist.:Chattogram
26	Foyjul Karim			Mouza: Raghobpur, Village:Tarakatia , Ward: 09, Union: Mirsarai Porasabha, Upz: Mirsarai, Dist.:Chattogram
27	Nur Alam		01850421531	Mouza: Raghobpur, Village:Tarakatia , Ward: 09, Union: Mirsarai Porasabha, Upz: Mirsarai, Dist.:Chattogram
28	Ala Uddin	1515365502670	01877542906	Mouza: Raghobpur, Village:Tarakatia , Ward: 09, Union: Mirsarai Porasabha, Upz: Mirsarai, Dist.:Chattogram
29	Nurul Huda			Mouza: Raghobpur, Village:Tarakatia , Ward: 09, Union: Mirsarai Porasabha, Upz: Mirsarai, Dist.:Chattogram
30	Nurul Abdar	15157246353	01837246353	Mouza: Raghobpur, Village:Tarakatia , Ward: 09, Union: Mirsarai Porasabha, Upz: Mirsarai, Dist.:Chattogram
31	Azizul Houqe	1515365509706	01821747326	Mouza: Raghobpur, Village:Tarakatia , Ward: 09, Union: Mirsarai Porasabha, Upz: Mirsarai, Dist.:Chattogram
32	Abul Hossain	1515365509885	01845143564	Mouza: Raghobpur, Village:Tarakatia , Ward: 09, Union: Mirsarai Porasabha, Upz: Mirsarai, Dist.:Chattogram
33	Nur Hossain			Mouza: Raghobpur, Village:Tarakatia , Ward: 09, Union: Mirsarai Porasabha, Upz: Mirsarai, Dist.:Chattogram
34	Abul Kalam Didar	1515365501972	01824206129	Mouza: Raghobpur, Village:Tarakatia , Ward: 09, Union: Mirsarai Porasabha, Upz: Mirsarai, Dist.:Chattogram
35	Khalilur Rahman	1515365509120	01813961034	Mouza: Raghobpur, Village:Tarakatia , Ward: 09, Union: Mirsarai Porasabha, Upz: Mirsarai, Dist.:Chattogram
36	Robiul Hossain		01892937701	Mouza: Raghobpur, Village:Tarakatia , Ward: 09, Union: Mirsarai Porasabha, Upz: Mirsarai, Dist.:Chattogram
37	Mihir Kumar Das	19711515365000044	01861660512	Mouza: Raghobpur, Village:Tarakatia , Ward: 09, Union: Mirsarai Porasabha, Upz: Mirsarai, Dist.:Chattogram
38	Shikha Rani Das			Mouza: Raghobpur, Village:Tarakatia , Ward: 09, Union: Mirsarai Porasabha, Upz: Mirsarai, Dist.:Chattogram
39	Dilp chondro Das			Mouza: Raghobpur, Village:Tarakatia , Ward: 09, Union: Mirsarai Porasabha, Upz: Mirsarai, Dist.:Chattogram
40	Sopon Chandro Das	1515365509632	01816370750	Mouza: Raghobpur, Village:Tarakatia , Ward: 09, Union: Mirsarai Porasabha, Upz: Mirsarai, Dist.:Chattogram
41	Tuni Bala Das	1515365509629	01834658154	Mouza: Raghobpur, Village:Tarakatia , Ward: 09, Union: Mirsarai Porasabha, Upz: Mirsarai, Dist.:Chattogram
42	Abu salek	5555966109	01850168861	Mouza: Raghobpur, Village:Tarakatia , Ward: 09, Union: Mirsarai Porasabha, Upz: Mirsarai, Dist.:Chattogram
43	Md Liton Mia			Mouza: Raghobpur, Village:Tarakatia , Ward: 09, Union: Mirsarai Porasabha, Upz: Mirsarai, Dist.:Chattogram
44	Abdur Rahim	4642105508	01628847153	Mouza: Raghobpur, Village:Tarakatia , Ward: 09, Union: Mirsarai Porasabha, Upz: Mirsarai, Dist.:Chattogram
45	Shamsul Houqe	1515365509988	0181263239	Mouza: Raghobpur, Village:Tarakatia , Ward: 09, Union: Mirsarai Porasabha, Upz: Mirsarai, Dist.:Chattogram
46	Md Fakir Ahmmed	1515365501978	01826358156	Mouza: Raghobpur, Village:Tarakatia , Ward: 09, Union: Mirsarai Porasabha, Upz: Mirsarai, Dist.:Chattogram
47	Akram Ali			Mouza: Raghobpur, Village:Tarakatia , Ward: 09, Union: Mirsarai Porasabha, Upz: Mirsarai, Dist.:Chattogram
48	Joynul Abedin	15153655097709		Mouza: Raghobpur, Village:Tarakatia , Ward: 09, Union: Mirsarai Porasabha, Upz: Mirsarai, Dist.:Chattogram
49	Md Mosttafizur Rahman	1503759805	01866439911	Mouza: Raghobpur, Village:Tarakatia , Ward: 09, Union: Mirsarai Porasabha, Upz: Mirsarai, Dist.:Chattogram
50	Md Shahidullah	1515365509625	01825247525	Mouza: Raghobpur, Village:Tarakatia , Ward: 09, Union: Mirsarai Porasabha, Upz: Mirsarai, Dist.:Chattogram
51	Shamima Nasrin	481794793158	01621094157	Mouza: Raghobpur, Village:Tarakatia , Ward: 09, Union: Mirsarai Porasabha, Upz: Mirsarai, Dist.:Chattogram
52	Joynul Abedin		01819989431	Mouza: Raghobpur, Village:Tarakatia , Ward: 09, Union: Mirsarai Porasabha, Upz: Mirsarai, Dist.:Chattogram
53	Md Josim Uddin Niyaji	1515365509673	01874778504	Mouza: Raghobpur, Village:Tarakatia , Ward: 09, Union: Mirsarai Porasabha, Upz: Mirsarai, Dist.:Chattogram
54	Aminul Houqe		01640519166	Mouza: Raghobpur, Village:Tarakatia , Ward: 09, Union: Mirsarai Porasabha, Upz: Mirsarai, Dist.:Chattogram
55	Bodiul Houqe	1515335509640	01830510200	Mouza: Raghobpur, Village:Tarakatia , Ward: 09, Union: Mirsarai Porasabha, Upz: Mirsarai, Dist.:Chattogram
56	Ripon Kumar Das	3275056756	01868302605	Mouza: Raghobpur, Village:Tarakatia , Ward: 09, Union: Mirsarai Porasabha, Upz: Mirsarai, Dist.:Chattogram
57	Sorowar Kamal			Mouza: Raghobpur, Village:Tarakatia , Ward: 09, Union: Mirsarai Porasabha, Upz: Mirsarai, Dist.:Chattogram
58	Md Iyasir	1515365501632	01818021267	Mouza: Raghobpur, Village:Tarakatia , Ward: 09, Union: Mirsarai Porasabha, Upz: Mirsarai, Dist.:Chattogram
59	Rejaul Karim	1515365509678	01881898158	Mouza: Raghobpur, Village:Tarakatia , Ward: 09, Union: Mirsarai Porasabha, Upz: Mirsarai, Dist.:Chattogram
60	Aminul Houqe			Mouza: Raghobpur, Village:Tarakatia , Ward: 09, Union: Mirsarai Porasabha, Upz: Mirsarai, Dist.:Chattogram

SI No.	Name	National Id	Contact No.	Address
61	Foyjul Houqe	1515365501985	01820826331	Mouza: Raghobpur, Village:Tarakatia , Ward: 09, Union: Mirsarai Porasabha, Upz: Mirsarai, Dist.:Chattogram
62	Jahanggir Alam	19721515365000018		Mouza: Raghobpur, Village:Tarakatia , Ward: 09, Union: Mirsarai Porasabha, Upz: Mirsarai, Dist.:Chattogram
63	josim Uddin	1515365509609	01883607498	Mouza: Raghobpur, Village:Tarakatia , Ward: 09, Union: Mirsarai Porasabha, Upz: Mirsarai, Dist.:Chattogram
64	Jamshed	1515365509601	01872165344	Mouza: Raghobpur, Village:Tarakatia , Ward: 09, Union: Mirsarai Porasabha, Upz: Mirsarai, Dist.:Chattogram
65	Jojurul Houqe	1515365509727	01860613229	Mouza: Raghobpur, Village:Tarakatia , Ward: 09, Union: Mirsarai Porasabha, Upz: Mirsarai, Dist.:Chattogram
66	Nurujjaman	1515365509128		Mouza: Raghobpur, Village:Tarakatia , Ward: 09, Union: Mirsarai Porasabha, Upz: Mirsarai, Dist.:Chattogram
67	Anbul Hossin	1515365509112	01812349491	Mouza: Raghobpur, Village:Tarakatia , Ward: 09, Union: Mirsarai Porasabha, Upz: Mirsarai, Dist.:Chattogram
68	Md Foizul Houqe	1515365509972		Mouza: Raghobpur, Village:Tarakatia , Ward: 09, Union: Mirsarai Porasabha, Upz: Mirsarai, Dist.:Chattogram
69	Abul Kashem	1525315458462	01819146513	Mouza: Raghobpur, Village:Tarakatia , Ward: 09, Union: Mirsarai Porasabha, Upz: Mirsarai, Dist.:Chattogram
70	Md Kamrujjaman	1525315479997	01817223190	Mouza: Raghobpur, Village:Tarakatia , Ward: 09, Union: Mirsarai Porasabha, Upz: Mirsarai, Dist.:Chattogram
71	Rehana akter	1525315479688	01614364790	Mouza: Raghobpur, Village:Tarakatia , Ward: 09, Union: Mirsarai Porasabha, Upz: Mirsarai, Dist.:Chattogram
72	Mosleh uddin	195768015	01630205252	Mouza: Raghobpur, Village:Tarakatia , Ward: 09, Union: Mirsarai Porasabha, Upz: Mirsarai, Dist.:Chattogram
73	Nijam Uddin		01822317785	Mouza: Raghobpur, Village:Tarakatia , Ward: 09, Union: Mirsarai Porasabha, Upz: Mirsarai, Dist.:Chattogram
74	Md Abul Basar	1515365161153	01883436265	Mouza: Raghobpur, Village:Tarakatia , Ward: 09, Union: Mirsarai Porasabha, Upz: Mirsarai, Dist.:Chattogram
75	Monirul Islam		01823718564	Mouza: Raghobpur, Village:Tarakatia , Ward: 09, Union: Mirsarai Porasabha, Upz: Mirsarai, Dist.:Chattogram
76	Rowson Jaman Manik		01818077349	Mouza: Raghobpur, Village:Tarakatia , Ward: 09, Union: Mirsarai Porasabha, Upz: Mirsarai, Dist.:Chattogram
77	Kobir Ahmmed	1525315479683	01817745425	Mouza: Raghobpur, Village:Tarakatia , Ward: 09, Union: Mirsarai Porasabha, Upz: Mirsarai, Dist.:Chattogram
78	Md Joinul Abedin	1525315458448		Mouza: Raghobpur, Village:Tarakatia , Ward: 09, Union: Mirsarai Porasabha, Upz: Mirsarai, Dist.:Chattogram
79	Ahidul Islam	1525315458642	01815063886	Mouza: Raghobpur, Village:Tarakatia , Ward: 09, Union: Mirsarai Porasabha, Upz: Mirsarai, Dist.:Chattogram
80	Md Harunur Roshid	1525316605731	01811629342	Mouza: Raghobpur, Village:Tarakatia , Ward: 09, Union: Mirsarai Porasabha, Upz: Mirsarai, Dist.:Chattogram
81	Md. Atikul Islam Latifi		01819801389	Mouza: Raghobpur, Village:Tarakatia , Ward: 09, Union: Mirsarai Porasabha, Upz: Mirsarai, Dist.:Chattogram
82	Md. Ripon			Mouza: Raghobpur, Village:Tarakatia , Ward: 09, Union: Mirsarai Porasabha, Upz: Mirsarai, Dist.:Chattogram
83	Komola Begum	1525315479694	01813728352	Mouza: Raghobpur, Village:Tarakatia , Ward: 09, Union: Mirsarai Porasabha, Upz: Mirsarai, Dist.:Chattogram
84	Md. Shahalam Bhutta		01839520576	Mouza: Raghobpur, Village:Tarakatia , Ward: 09, Union: Mirsarai Porasabha, Upz: Mirsarai, Dist.:Chattogram
85	Md. Nurul Islam		01878299777	Mouza: Raghobpur, Village:Tarakatia , Ward: 09, Union: Mirsarai Porasabha, Upz: Mirsarai, Dist.:Chattogram
86	Md. Nurunnabi	1525315479851	01864884620	Mouza: Raghobpur, Village:Tarakatia , Ward: 09, Union: Mirsarai Porasabha, Upz: Mirsarai, Dist.:Chattogram
87	Md. Jahangir Alam		01990155509	Mouza: Raghobpur, Village:Tarakatia , Ward: 09, Union: Mirsarai Porasabha, Upz: Mirsarai, Dist.:Chattogram
88	Md. Faridul Islam		01614364789	Mouza: Raghobpur, Village:Tarakatia , Ward: 09, Union: Mirsarai Porasabha, Upz: Mirsarai, Dist.:Chattogram
89	Md. Jashim Uddin		01826577743	Mouza: Raghobpur, Village:Tarakatia , Ward: 09, Union: Mirsarai Porasabha, Upz: Mirsarai, Dist.:Chattogram
90	Mezba Ul Islam Latifi		01715146709	Mouza: Raghobpur, Village:Tarakatia , Ward: 09, Union: Mirsarai Porasabha, Upz: Mirsarai, Dist.:Chattogram
91	Md. Ohidul Islam Latifi		01715052522	Mouza: Raghobpur, Village:Tarakatia , Ward: 09, Union: Mirsarai Porasabha, Upz: Mirsarai, Dist.:Chattogram
92	Md. Momtaz Islam Latifi			Mouza: Raghobpur, Village:Tarakatia , Ward: 09, Union: Mirsarai Porasabha, Upz: Mirsarai, Dist.:Chattogram
93	Abul Kalam	19621525317000002	01819369876	Mouza: Raghobpur, Village:Tarakatia , Ward: 09, Union: Mirsarai Porasabha, Upz: Mirsarai, Dist.:Chattogram
94	Nizamul Haque	1525317728249	01822911573	Mouza: Raghobpur, Village:Tarakatia , Ward: 09, Union: Mirsarai Porasabha, Upz: Mirsarai, Dist.:Chattogram
95	Sapan Kumar Nath	1515359680290	01820006938	Mouza: Raghobpur, Village:Tarakatia , Ward: 09, Union: Mirsarai Porasabha, Upz: Mirsarai, Dist.:Chattogram
96	Nikhil Chandro Nath	1515359686297	01877199590	Mouza: Raghobpur, Village:Tarakatia , Ward: 09, Union: Mirsarai Porasabha, Upz: Mirsarai, Dist.:Chattogram

SI No.	Name	National Id	Contact No.	Address
97	Rajib Chandra Nath	19921515359000201	01814948955	Mouza: Raghobpur, Village:Tarakatia , Ward: 09, Union: Mirsarai Porasabha, Upz: Mirsarai, Dist.:Chattogram
98	Monindro Kumar Nath		01812821847	Mouza: Raghobpur, Village:Tarakatia , Ward: 09, Union: Mirsarai Porasabha, Upz: Mirsarai, Dist.:Chattogram
99	Sadhon Chandro Nath	19611515359000002	01641403733	Mouza: Raghobpur, Village:Tarakatia , Ward: 09, Union: Mirsarai Porasabha, Upz: Mirsarai, Dist.:Chattogram
100	Lakkhan Chandro Nath		01879717346	Mouza: Raghobpur, Village:Tarakatia , Ward: 09, Union: Mirsarai Porasabha, Upz: Mirsarai, Dist.:Chattogram
101	Lutfor Rahman	19461515365000001	01716609150	Mouza: Raghobpur, Village:Tarakatia , Ward: 09, Union: Mirsarai Porasabha, Upz: Mirsarai, Dist.:Chattogram
102	Aman Ullah	19621515365007674	01817250144	Mouza: Raghobpur, Village:Tarakatia , Ward: 09, Union: Mirsarai Porasabha, Upz: Mirsarai, Dist.:Chattogram
103	Mollika Begum	1515365503669	01830062418	Mouza: Raghobpur, Village:Tarakatia , Ward: 09, Union: Mirsarai Porasabha, Upz: Mirsarai, Dist.:Chattogram
104	Md. Emdadul Haque	1525317728246	01832586622	Mouza: Raghobpur, Village:Tarakatia , Ward: 09, Union: Mirsarai Porasabha, Upz: Mirsarai, Dist.:Chattogram
105	Taposh Chandra Nath			Mouza: Raghobpur, Village:Tarakatia , Ward: 09, Union: Mirsarai Porasabha, Upz: Mirsarai, Dist.:Chattogram
106	Rozit Kumar Nath		01641402970	Mouza: Raghobpur, Village:Tarakatia , Ward: 09, Union: Mirsarai Porasabha, Upz: Mirsarai, Dist.:Chattogram
107	Dulal Chandra Nath	1515359686304	01831955561	Mouza: Raghobpur, Village:Tarakatia , Ward: 09, Union: Mirsarai Porasabha, Upz: Mirsarai, Dist.:Chattogram
108	Minu Rani Nath	1515359686300	01840381409	Mouza: Raghobpur, Village:Tarakatia , Ward: 09, Union: Mirsarai Porasabha, Upz: Mirsarai, Dist.:Chattogram
109	Sudhir Chandra Nath			Mouza: Raghobpur, Village:Tarakatia , Ward: 09, Union: Mirsarai Porasabha, Upz: Mirsarai, Dist.:Chattogram
110	Saidul Karim			Mouza: Raghobpur, Village:Tarakatia , Ward: 09, Union: Mirsarai Porasabha, Upz: Mirsarai, Dist.:Chattogram
111	Jamal Ullah		01822317785	Mouza: Raghobpur, Village:Tarakatia , Ward: 09, Union: Mirsarai Porasabha, Upz: Mirsarai, Dist.:Chattogram
112	Josna Ara Begum	1515365503667	01866556432	Mouza: Raghobpur, Village:Tarakatia , Ward: 09, Union: Mirsarai Porasabha, Upz: Mirsarai, Dist.:Chattogram
113	Orjun Kumar Das	1515365509653	01817746962	Mouza: Raghobpur, Village:Tarakatia , Ward: 09, Union: Mirsarai Porasabha, Upz: Mirsarai, Dist.:Chattogram
114	Md. Alahi Box		01817228365	Mouza: Raghobpur, Village:Tarakatia , Ward: 09, Union: Mirsarai Porasabha, Upz: Mirsarai, Dist.:Chattogram
115	Md. Ibrahim	1515359430348	01824871269	Mouza: Raghobpur, Village:Tarakatia , Ward: 09, Union: Mirsarai Porasabha, Upz: Mirsarai, Dist.:Chattogram
116	Md. Mosleh Uddin	09118581036725	01813820264	Mouza: Raghobpur, Village:Tarakatia , Ward: 09, Union: Mirsarai Porasabha, Upz: Mirsarai, Dist.:Chattogram
117	Jahanara Begum	19691525314000001	01786295731	Mouza: Raghobpur, Village:Tarakatia , Ward: 09, Union: Mirsarai Porasabha, Upz: Mirsarai, Dist.:Chattogram

#### d. South to Sheikh Hasina Saroni Road

SI No.	Name	National Id	Contact No.	Address
1	Shamsul Huda	1515353197812	01884291062	Mouza: Poschim Mayani, Village:Poschim Mayani, Ward: 09, Union: 13 No. Mayani, Upz: Mirsarai, Dist.:Chattogram
2	Nurul Karim		01813679089	Mouza: Poschim Mayani, Village:Poschim Mayani, Ward: 09, Union: 13 No. Mayani, Upz: Mirsarai, Dist.:Chattogram
3	Md. Nur Baksh	19721515383104486		Mouza: Poschim Mayani, Village:Poschim Mayani, Ward: 09, Union: 13 No. Mayani, Upz: Mirsarai, Dist.:Chattogram
4	Md. Didarul Alam	1982151538000	01872901999	Mouza: Poschim Mayani, Village:Poschim Mayani, Ward: 09, Union: 13 No. Mayani, Upz: Mirsarai, Dist.:Chattogram
5	kajal Chandra Das	1515347474516	01826536797	Mouza: Poschim Mayani, Village:Poschim Mayani, Ward: 09, Union: 13 No. Mayani, Upz: Mirsarai, Dist.:Chattogram
6	Badol Das		01818165342	Mouza: Poschim Mayani, Village:Poschim Mayani, Ward: 09, Union: 13 No. Mayani, Upz: Mirsarai, Dist.:Chattogram
7	Rakhal Das		01814781754	Mouza: Poschim Mayani, Village:Poschim Mayani, Ward: 09, Union: 13 No. Mayani, Upz: Mirsarai, Dist.:Chattogram
8	Sukumar Das	1515347474738	01915745478	Mouza: Poschim Mayani, Village:Poschim Mayani, Ward: 09, Union: 13 No. Mayani, Upz: Mirsarai, Dist.:Chattogram
9	Dulal Das	1515347474599	01813373116	Mouza: Purba Mayani, Village:Mayani Purba para, Ward: 04, Union: 13 No. Mayani, Upz: Mirsarai, Dist.:Chattogram
10	Towan Chandra Das	1515347474689	01815101074	Mouza: Purba Mayani, Village:Mayani Purba para, Ward: 04, Union: 13 No. Mayani, Upz: Mirsarai, Dist.:Chattogram
11	Sanjay Barua	199015515353000012	01823051067	Mouza: Purba Mayani, Village:Mayani Purba para, Ward: 04, Union: 13 No. Mayani, Upz: Mirsarai, Dist.:Chattogram
12	Shipok Barua	1515353196737	01834248400	Mouza: Purba Mayani, Village:Mayani Purba para, Ward: 04, Union: 13 No. Mayani, Upz: Mirsarai, Dist.:Chattogram
13	Nuruzzaman	1515353190137		Mouza: Purba Mayani, Village:Mayani Purba para, Ward: 04, Union: 13 No. Mayani, Upz: Mirsarai, Dist.:Chattogram

SI No.	Name	National Id	Contact No.	Address
14	Anwarul Isam	199215153	01858475761	Mouza: Purba Mayani, Village:Mayani Purba para, Ward: 04, Union: 13 No. Mayani, Upz: Mirsarai, Dist.:Chattogram
15	Abul Kasem		01816049813	Mouza: Purba Mayani, Village:Mayani Purba para, Ward: 04, Union: 13 No. Mayani, Upz: Mirsarai, Dist.:Chattogram
16	Niru Begum		01874783224	Mouza: Purba Mayani, Village:Mayani Purba para, Ward: 04, Union: 13 No. Mayani, Upz: Mirsarai, Dist.:Chattogram
17	Rupan das	1515347474792		Mouza: Purba Mayani, Village:Mayani Purba para, Ward: 04, Union: 13 No. Mayani, Upz: Mirsarai, Dist.:Chattogram
18	Krishna Chandra das	1515347474640		Mouza: Purba Mayani, Village:Mayani Purba para, Ward: 04, Union: 13 No. Mayani, Upz: Mirsarai, Dist.:Chattogram
19	Topon das		01863922308	Mouza: Purba Mayani, Village:Mayani Purba para, Ward: 04, Union: 13 No. Mayani, Upz: Mirsarai, Dist.:Chattogram
20	Uttomkumar Nath		01824956973	Mouza: Purba Mayani, Village:Mayani Purba para, Ward: 04, Union: 13 No. Mayani, Upz: Mirsarai, Dist.:Chattogram
21	Bashu Chandra Nath		01813408581	Mouza: Purba Mayani, Village:Mayani Purba para, Ward: 04, Union: 13 No. Mayani, Upz: Mirsarai, Dist.:Chattogram
22	Dipak Kumar Nath		01817782835	Mouza: Purba Mayani, Village:Mayani Purba para, Ward: 04, Union: 13 No. Mayani, Upz: Mirsarai, Dist.:Chattogram
23	Shankar Kumar Nath	1515347474650	01817224112	Mouza: Purba Mayani, Village:Mayani Purba para, Ward: 04, Union: 13 No. Mayani, Upz: Mirsarai, Dist.:Chattogram
24	Ashish Kumar Nath			Mouza: Purba Mayani, Village:Mayani Purba para, Ward: 04, Union: 13 No. Mayani, Upz: Mirsarai, Dist.:Chattogram
25	Md. Ishak Vuiya		01817754629	Mouza: Purba Mayani, Village:Mayani Purba para, Ward: 04, Union: 13 No. Mayani, Upz: Mirsarai, Dist.:Chattogram
26	Ashraf Uddin			Mouza: Purba Mayani, Village:Mayani Purba para, Ward: 04, Union: 13 No. Mayani, Upz: Mirsarai, Dist.:Chattogram
27	Abdul Awal (Sovapoti)			Mouza: Purba Mayani, Village:Mayani Purba para, Ward: 04, Union: 13 No. Mayani, Upz: Mirsarai, Dist.:Chattogram
28	Amir Barua	1515353193168	01824455812	Mouza: Purba Mayani, Village:Mayani Purba para, Ward: 04, Union: 13 No. Mayani, Upz: Mirsarai, Dist.:Chattogram
29	Rakhai Barua			Mouza: Purba Mayani, Village:Mayani Purba para, Ward: 04, Union: 13 No. Mayani, Upz: Mirsarai, Dist.:Chattogram
30	Amol Barua	1515353196440	018143949536	Mouza: Purba Mayani, Village:Mayani Purba para, Ward: 04, Union: 13 No. Mayani, Upz: Mirsarai, Dist.:Chattogram
31	Suresh Barua	1515353193435	01869469006	Mouza: Purba Mayani, Village:Mayani Purba para, Ward: 04, Union: 13 No. Mayani, Upz: Mirsarai, Dist.:Chattogram
32	Noni Gopal das	1515347474797		Mouza: Purba Mayani, Village:Mayani Purba para, Ward: 04, Union: 13 No. Mayani, Upz: Mirsarai, Dist.:Chattogram
33	Montrisen Barua	1515353193437	01585758108	Mouza: Purba Mayani, Village:Mayani Purba para, Ward: 04, Union: 13 No. Mayani, Upz: Mirsarai, Dist.:Chattogram
34	Rabindra Chandra Das	1515347474544	01814486836	Mouza: Purba Mayani, Village:Mayani Purba para, Ward: 04, Union: 13 No. Mayani, Upz: Mirsarai, Dist.:Chattogram
35	Kishore Chandra Shil		01869469170	Mouza: Purba Mayani, Village:Mayani Purba para, Ward: 04, Union: 13 No. Mayani, Upz: Mirsarai, Dist.:Chattogram
36	Anjan Kumar Shil	1515347474688	01830140479	Mouza: Purba Mayani, Village:Mayani Purba para, Ward: 04, Union: 13 No. Mayani, Upz: Mirsarai, Dist.:Chattogram
37	Md. Joynal Abedin		01819545560	Mouza: Purba Mayani, Village:Mayani Purba para, Ward: 04, Union: 13 No. Mayani, Upz: Mirsarai, Dist.:Chattogram
38	Md. Jahangir Alam	1515343474831	01830127403	Mouza: Purba Mayani, Village:Mayani Purba para, Ward: 04, Union: 13 No. Mayani, Upz: Mirsarai, Dist.:Chattogram
39	Nirmal Sharma Shil	1515347474623	01817055962	Mouza: Purba Mayani, Village:Mayani Purba para, Ward: 04, Union: 13 No. Mayani, Upz: Mirsarai, Dist.:Chattogram
40	Manik Chandra Das	1515377474778	01815862587	Mouza: Purba Mayani, Village:Mayani Purba para, Ward: 04, Union: 13 No. Mayani, Upz: Mirsarai, Dist.:Chattogram
41	Soumik Shil		01815681045	Mouza: Purba Mayani, Village:Mayani Purba para, Ward: 04, Union: 13 No. Mayani, Upz: Mirsarai, Dist.:Chattogram
42	Monirul Islam	1515353190124	01863204283	Mouza: Purba Mayani, Village:Mayani Purba para, Ward: 04, Union: 13 No. Mayani, Upz: Mirsarai, Dist.:Chattogram
43	Abu Zafar	19711515353000008	01818022617	Mouza: Purba Mayani, Village:Mayani Purba para, Ward: 04, Union: 13 No. Mayani, Upz: Mirsarai, Dist.:Chattogram
44	Deepak Barua	1515353196425	01799630813	Mouza: Purba Mayani, Village:Mayani Purba para, Ward: 04, Union: 13 No. Mayani, Upz: Mirsarai, Dist.:Chattogram
45	Sujit Kumar Barua		01819333642	Mouza: Purba Mayani, Village:Mayani Purba para, Ward: 04, Union: 13 No. Mayani, Upz: Mirsarai, Dist.:Chattogram
46	Pintu Barua	1515353196249	01869095050	Mouza: Purba Mayani, Village:Mayani Purba para, Ward: 04, Union: 13 No. Mayani, Upz: Mirsarai, Dist.:Chattogram
47	Sudam Chandra Das	1515347474611	01830047427	Mouza: Purba Mayani, Village:Mayani Purba para, Ward: 04, Union: 13 No. Mayani, Upz: Mirsarai, Dist.:Chattogram
48	Maron Bala Das	1515347474616	01811611318	Mouza: Purba Mayani, Village:Mayani Purba para, Ward: 04, Union: 13 No. Mayani, Upz: Mirsarai, Dist.:Chattogram
49	Haradhon Sheel	1515347474666	01831414524	Mouza: Purba Mayani, Village:Mayani Purba para, Ward: 04, Union: 13 No. Mayani, Upz: Mirsarai, Dist.:Chattogram
50	Jagodish Chondro	3298338652	01830055959	Mouza: Purba Mayani, Village:Mayani Purba para, Ward: 04, Union: 13 No. Mayani, Upz: Mirsarai, Dist.:Chattogram

SI No.	Name	National Id	Contact No.	Address
	Sheel			
51	Raton Nath			Mouza: Purba Mayani, Village:Mayani Purba para, Ward: 04, Union: 13 No. Mayani, Upz: Mirsarai, Dist.:Chattogram
52	Kushid Alam			Mouza: Purba Mayani, Village:Mayani Purba para, Ward: 04, Union: 13 No. Mayani, Upz: Mirsarai, Dist.:Chattogram
53	Jhumka Barua	1515353193413	01882587896	Mouza: Purba Mayani, Village:Mayani Barua Para, Ward: 03, Union: 13 No. Mayani, Upz: Mirsarai, Dist.:Chattogram
54				Mouza: Purba Mayani, Village:Mayani Barua Para, Ward: 03, Union: 13 No. Mayani, Upz: Mirsarai, Dist.:Chattogram
55	Swapon Barua	1515353196296	01837685106	Mouza: Purba Mayani, Village:Mayani Barua Para, Ward: 03, Union: 13 No. Mayani, Upz: Mirsarai, Dist.:Chattogram
56	Bhodroshen Barua	19671515353000007	01846329070	Mouza: Purba Mayani, Village:Mayani Barua Para, Ward: 03, Union: 13 No. Mayani, Upz: Mirsarai, Dist.:Chattogram
57	Jashim Uddin	1515353197129	01843051569	Mouza: Purba Mayani, Village:Mayani Barua Para, Ward: 03, Union: 13 No. Mayani, Upz: Mirsarai, Dist.:Chattogram
58	Jamal Hossain			Mouza: Purba Mayani, Village:Mayani Barua Para, Ward: 03, Union: 13 No. Mayani, Upz: Mirsarai, Dist.:Chattogram
59	Sumon Chandra Das	1515347474514	01832750756	Mouza: Purba Mayani, Village:Mayani Barua Para, Ward: 03, Union: 13 No. Mayani, Upz: Mirsarai, Dist.:Chattogram
60	Sadhon Chondro Das	1515347474513	01812086384	Mouza: Purba Mayani, Village:Mayani Barua Para, Ward: 03, Union: 13 No. Mayani, Upz: Mirsarai, Dist.:Chattogram
61	Aminul Haque	1515353190125	01400366883	Mouza: Purba Mayani, Village:Mayani Barua Para, Ward: 03, Union: 13 No. Mayani, Upz: Mirsarai, Dist.:Chattogram
62	Dilip Kumar Barua	1515353196843	01836013219	Mouza: Purba Mayani, Village:Mayani Barua Para, Ward: 03, Union: 13 No. Mayani, Upz: Mirsarai, Dist.:Chattogram
63	Bholon Barua	1515353196736	01875977294	Mouza: Purba Mayani, Village:Mayani Barua Para, Ward: 03, Union: 13 No. Mayani, Upz: Mirsarai, Dist.:Chattogram
64	Subol Chondra Sharma		01891676362	Mouza: Purba Mayani, Village:Masjidia Hindu Para, Ward: 09, Union: 12 No. Khoia chara, Upz: Mirsarai, Dist.:Chattogram
65	Dilip Kumar Sharma			Mouza: Purba Mayani, Village:Masjidia Hindu Para, Ward: 09, Union: 12 No. Khoia chara, Upz: Mirsarai, Dist.:Chattogram
66	Nipul Chondro Nath	1497333888	0155891556	Mouza: Purba Mayani, Village:Masjidia Hindu Para, Ward: 09, Union: 12 No. Khoia chara, Upz: Mirsarai, Dist.:Chattogram
67	Shimul Sharma		01879302676	Mouza: Purba Mayani, Village:Masjidia Hindu Para, Ward: 09, Union: 12 No. Khoia chara, Upz: Mirsarai, Dist.:Chattogram
68	Dilip Kumar Sharma	1515347474527	01819616055	Mouza: Purba Mayani, Village:Masjidia Hindu Para, Ward: 09, Union: 12 No. Khoia chara, Upz: Mirsarai, Dist.:Chattogram
69	Shima Sharma	1515347474787	01879735404	Mouza: Purba Mayani, Village:Masjidia Hindu Para, Ward: 09, Union: 12 No. Khoia chara, Upz: Mirsarai, Dist.:Chattogram
70	Swapon Chondro Das	1515347474751	01825131703	Mouza: Purba Mayani, Village:Masjidia Hindu Para, Ward: 09, Union: 12 No. Khoia chara, Upz: Mirsarai, Dist.:Chattogram
71	Bimvu Barua	1515353196119	01825037356	Mouza: Purba Mayani, Village:Masjidia Hindu Para, Ward: 09, Union: 12 No. Khoia chara, Upz: Mirsarai, Dist.:Chattogram
72	Md. Faruqe Hossain	3745590202	01839506696	Mouza: Purba Mayani, Village:Masjidia Hindu Para, Ward: 09, Union: 12 No. Khoia chara, Upz: Mirsarai, Dist.:Chattogram
73	Bashonti Sharma	1515347474546	01849211404	Mouza: Purba Mayani, Village:Masjidia Hindu Para, Ward: 09, Union: 12 No. Khoia chara, Upz: Mirsarai, Dist.:Chattogram
74	Liton Kumar Sharma	1515347474538	01876937282	Mouza: Purba Mayani, Village:Masjidia Hindu Para, Ward: 09, Union: 12 No. Khoia chara, Upz: Mirsarai, Dist.:Chattogram
75	Polash Sharma		01820101112	Mouza: Purba Mayani, Village:Masjidia Hindu Para, Ward: 09, Union: 12 No. Khoia chara, Upz: Mirsarai, Dist.:Chattogram
76	Nuber Nobi	1515353190827	01833504996	Mouza: Purba Mayani, Village:Masjidia Hindu Para, Ward: 09, Union: 12 No. Khoia chara, Upz: Mirsarai, Dist.:Chattogram
77	Kalu Barua	1515353196292	01862109332	Mouza: Purba Mayani, Village:Masjidia Hindu Para, Ward: 09, Union: 12 No. Khoia chara, Upz: Mirsarai, Dist.:Chattogram
78	Diplu Barua			Mouza: Purba Mayani, Village:Masjidia Hindu Para, Ward: 09, Union: 12 No. Khoia chara, Upz: Mirsarai, Dist.:Chattogram
79	Bhubonessor Barua	1515353196744	01887785912	Mouza: Purba Mayani, Village:Masjidia Hindu Para, Ward: 09, Union: 12 No. Khoia chara, Upz: Mirsarai, Dist.:Chattogram
80	Abul Kashem	1515353197130	01305995096	Mouza: Purba Mayani, Village:Masjidia Hindu Para, Ward: 09, Union: 12 No. Khoia chara, Upz: Mirsarai, Dist.:Chattogram
81	Manik Chandro Das	19571515347000003	01820188418	Mouza: Purba Mayani, Village:Masjidia Hindu Para, Ward: 09, Union: 12 No. Khoia chara, Upz: Mirsarai, Dist.:Chattogram
82	Bipul Das	1515347474526	01711128429	Mouza: Purba Mayani, Village:Masjidia Hindu Para, Ward: 09, Union: 12 No. Khoia chara, Upz: Mirsarai, Dist.:Chattogram
83	Rejaul Karim	1515353197729	01870040168	Mouza: Purba Mayani, Village:Masjidia Hindu Para, Ward: 09, Union: 12 No. Khoia chara, Upz: Mirsarai, Dist.:Chattogram
84	Md. Sirajuddola	1515383481670	01837835496	Mouza: Purba Mayani, Village:Masjidia Hindu Para, Ward: 09, Union: 12 No. Khoia chara, Upz: Mirsarai, Dist.:Chattogram





